

# ewst

Scaffolding • Formwork • Engineering

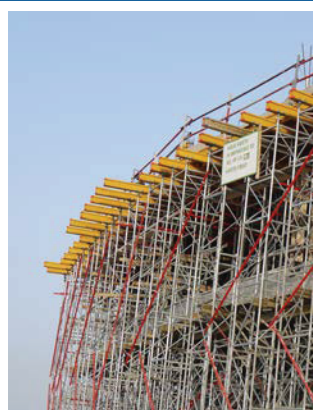

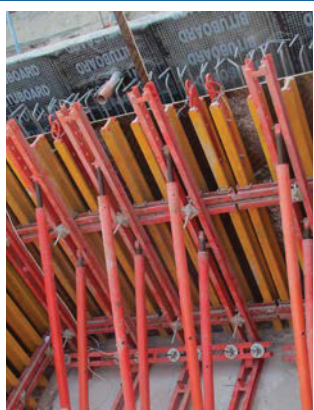

# Table of Content

Company Profile	- 4
Organization Chart	- 6
Product Portfolio	- 7
Material Test Certificates	- 100
Engineering Designs	- 110
Formwork Site Photo	- 116
Completed Projects	- 134

# COMPANY PROFILE

## INTRODUCTION

We are pleased to introduce our Company as one of the market leaders, Supplying, Renting & Engineering of advance formwork and providing compatible and comprehensive solutions in the Gulf, Middle East region, Europe and in India for construction companies.

Emirates World Scaffolding Trading LLC (EWST) was established in Dubai - United Arab Emirates in 2003, and since then has grown and expanded in the field of Selling, Hiring & Engineering Services of various brands of formwork systems to suit all construction Industries.

Along with supplying FORMWORK SYSTEMS and COMPONENTS, Clients satisfaction is EWST main concern, therefore we in EWST always consider ourselves as a partner and a full solution provider for our clients. Our services includes design, supply, site supervision, technical support and formwork consultation.

Along the way EWST has assembled a huge worldwide Network for Trading, Marketing and Procurement of the various brands and different Systems of Formwork.

EWST supply used Engineered Formwork Systems such as Doka, Peri, Huennebeck, Tabla, Meva and from other leading makers .

We are the distributor for Kaufmann H20 Timber Beams.





# Certificate

SWISS CERT Pvt. Ltd. hereby certify that the Quality Management System of

## **EMIRATES WORLD SCAFFOLDING TRADING LLC**

**P.O BOX 38277, PLOT #TP010213, NIP, JEBEL ALI, DUBAI, UAE**

has been assessed and found to be in accordance with the requirements of

## **Quality Management System ISO 9001:2015**

and scope of activities are detailed below

- BUILDING & CONSTRUCTION MATERIALS TRADING
- CONSTRUCTION EQUIPMENT & MACHINERY TRADING
- CONSTRUCTION EQUIPMENT & MACHINERY RENTAL
- SCAFFOLDS TRADING
- SCAFFOLDS RENTAL
- WOODEN PRODUCTS TRADING

This Certificate is valid for a period of Three years from: 11.04.2023 until: 10.04.2026  
And remains valid Subject to satisfactory completion of surveillance audits

Certificate Number: 211557

Rev. No: 00



*[Signature]*  
Director

**SWISS CERT PVT. LTD.**

412, BEST SKY TOWER, NEETAJI SUBHASH PLACE, PITAMPURA, DELHI - 110 034, INDIA

This certificate is the property of SWISS CERT PRIVATE LIMITED and shall be returned upon request.

All Interested parties are advised to verify the validity of the certificate from SWISSCERT ([info@swisoindia.com](mailto:info@swisoindia.com))

# Organization Chart





# Products Portfolio

## Slab Formwork

Slabflex	8
H20 Slab Table	24
Alu Top Deck	32
T-15 Tower	40

## Wall Formwork

H20 Wall & Column Formwork	56
Steel Column Panel	84
Single Sided Wall	94



# SLABFLEX

A FLEXIBLE SLAB FORMWORK SYSTEM



## Product Features

In combination with tubular steel props, tripod stands, fork heads and shuttering panels, the H20 beams provide flexible, yet cost-effective soffit formwork for any ground-plan, slab thickness and room height upto 5.50m.

The H20 timber beam is especially practical due to its low weight ( 4.60 kg/m ), its good statical figures, and its exacting workmanship in details. A very long duration of life is assured by its high-grade bonding and its rounded beam ends.

## Important notes:

The following instructions for erection and use include detailed information on the handling and proper application of the products that are described and depicted.

All instructions regarding technical operation and function have to be observed carefully. Exceptional use requires a separate design calculation. With regard to safe and technically correct use of our products abroad, all relevant safety rules, regulations and safety instructions of national institutes and/or local authorities have to be followed. Generally, only flawless material must be used. Damaged components have to be sorted out. In case of repairs, only original spare parts of the Company may be used.

Combined use of our formwork system with equipment from other suppliers may involve certain dangers and, therefore, requires an additional checkup.

For reasons of further technical development we emphatically reserve the right to revise, change or modify any of the product's components at any time without prior notice.



# Overview

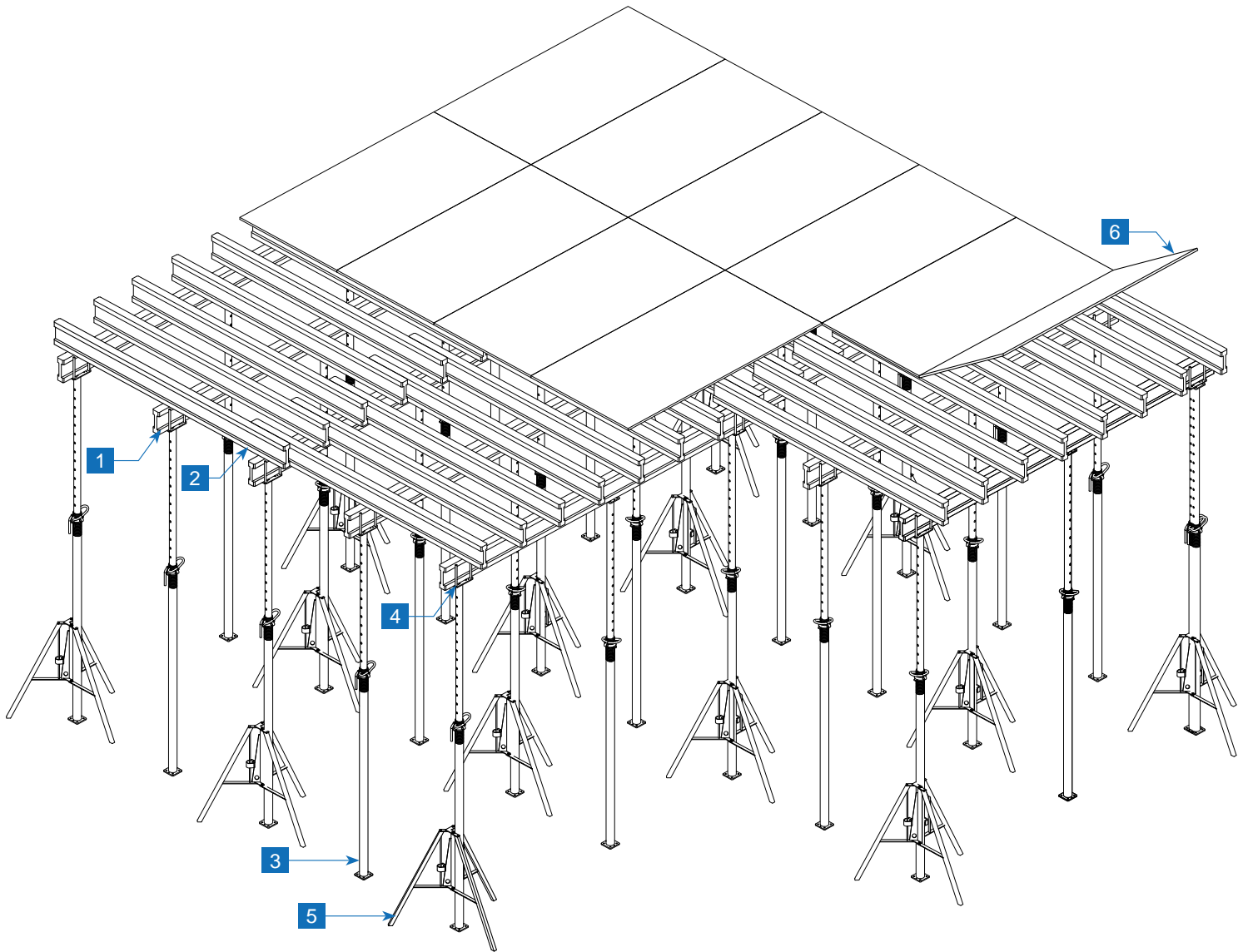

- 1. H20 Primary Beam
- 2. H20 Secondary Beam
- 3. Steel Prop
- 4. Fork Head
- 5. Tripod
- 6. Plywood

System Components

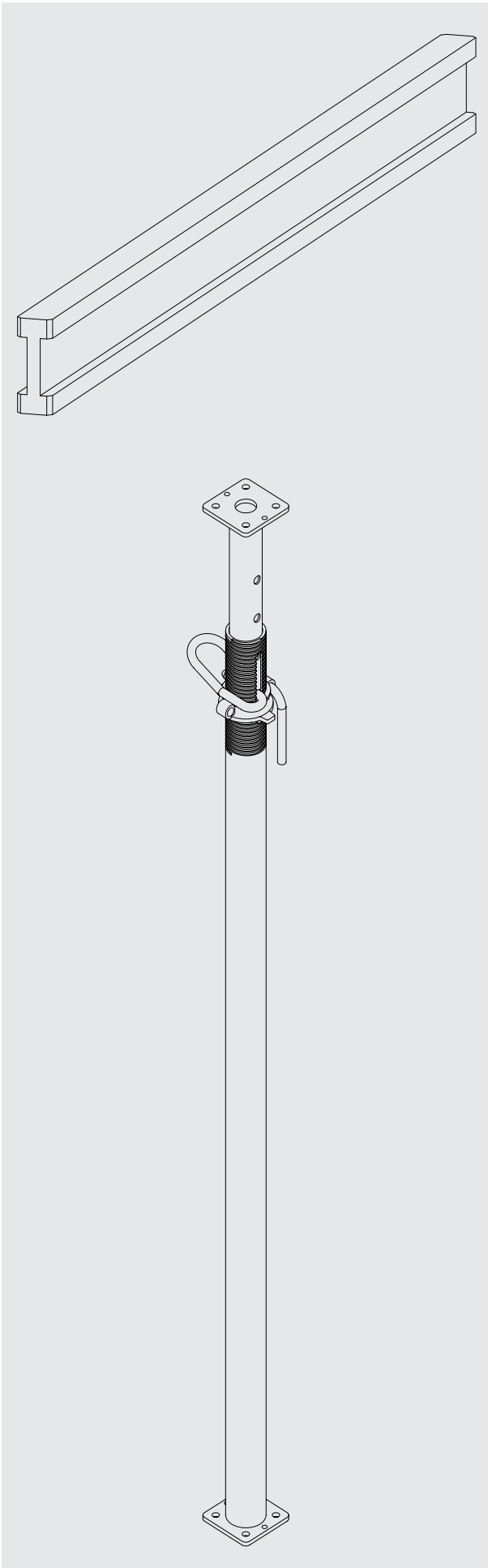

Description

Art. No

Weight

H20 Timber Beam

With End cap protection

Description	Art. No	Weight
H20 - Timber Beam 2.00	0000018	9.20
H20 - Timber Beam 2.45	0000002	11.27
H20 - Timber Beam 2.65	0000003	12.19
H20 - Timber Beam 3.00	0000016	13.80
H20 - Timber Beam 3.30	0000005	15.18
H20 - Timber Beam 3.60	0000006	16.56
H20 - Timber Beam 3.90	0000007	17.94
H20 - Timber Beam 4.50	0000008	20.70
H20 - Timber Beam 4.90	0000009	22.54
H20 - Timber Beam 5.50	0000014	25.30
H20 - Timber Beam 5.90	0000010	27.14

Steel Prop

The inner and outer tubes, including the threads, are hot-dip galvanized steel which ensure the quality and high durability of tubular steel props. EWST

20kN Prop

Description	Art. No	Weight
Galv. Prop 20-260 (L=1.54 - 2.60 m)	601260	13.40
Galv. Prop 20-300 (L=1.72 - 3.00 m)	601300	16.20
Galv. Prop 20-350 (L=1.98 - 3.50 m)	601350	19.80
Galv. Prop 20-400 (L=2.24 - 4.00 m)	601400	23.70
Galv. Prop 20-500 (L=2.72 - 5.00 m)	601500	31.70
Galv. Prop 20-550 (L=3.05 - 5.50 m)	601550	38.00



30kN Prop

Description	Art. No	Weight
Galv. Prop 20-260 (L=1.54 - 2.60 m)	600260	15.20
Galv. Prop 20-300 (L=1.72 - 3.00 m)	600300	16.70
Galv. Prop 20-350 (L=1.98 - 3.50 m)	600350	20.70
Galv. Prop 20-400 (L=2.24 - 4.00 m)	600400	25.00

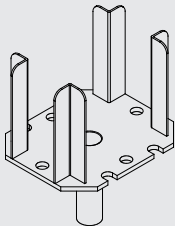
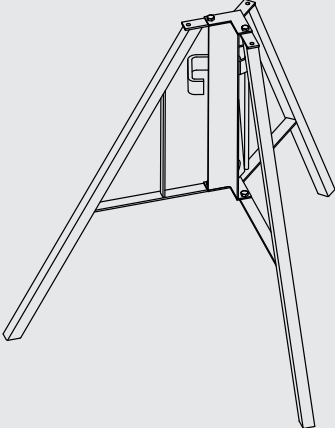
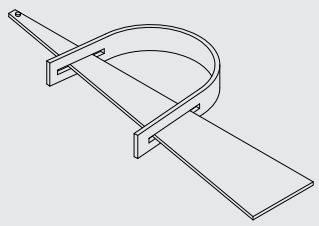
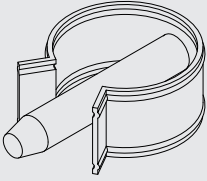
**System Components**

	Description	Art. No	Weight
	<p><b>Galv. Fork Head 8/20</b></p> <p>The fork head serves to keep the primary beam in position and protect the h20 timber beam from falling down</p>	<p>601101</p>	<p>3.10</p>
	<p><b>Galv. Tripod</b></p> <p>For easy and quick erection of the prop for slab formwork assembly used.</p>	<p>601100</p>	<p>11.60</p>
	<p><b>Bracing Clamp</b></p> <p>Provides stiffening by means of shutter boards to any tubular steel prop.</p>	<p>601108</p>	<p>1.40</p>
	<p><b>T-Bolt</b></p> <p>Used for fixing and securing the Fork Head to the Inner Tube of the steel props.</p>	<p>660661</p>	<p>0.15</p>

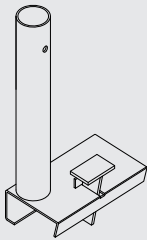
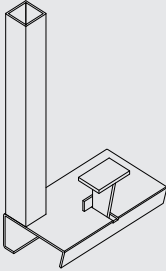
System Components

	Description	Art. No	Weight
	<p><b>Timber Beam Attachment-C</b></p> <p>The Timber Beam Attachment C is fixed by Wedge and serves as the holding device for the Railing Post C and as an alternative to Bolt Socket C.</p>	<p>660663</p>	<p>3.40</p>
	<p><b>H20 Base Shoe SQ</b></p> <p>It is fixed on the H20 Timber beam by Wedge and serves as the holding device for Safety Post</p>	<p>660662</p>	<p>3.40</p>
	<p><b>Safety Post</b></p> <p>Inserted in the H20 base shoe and serves as guard rail to prevent falls.</p>	<p>601103</p>	<p>3.15</p>
	<p><b>Assembly Fork</b></p> <p>Simplifies erection and dismantling of H20 shuttering beams.</p>	<p>601102</p>	<p>3.40</p>

Overview

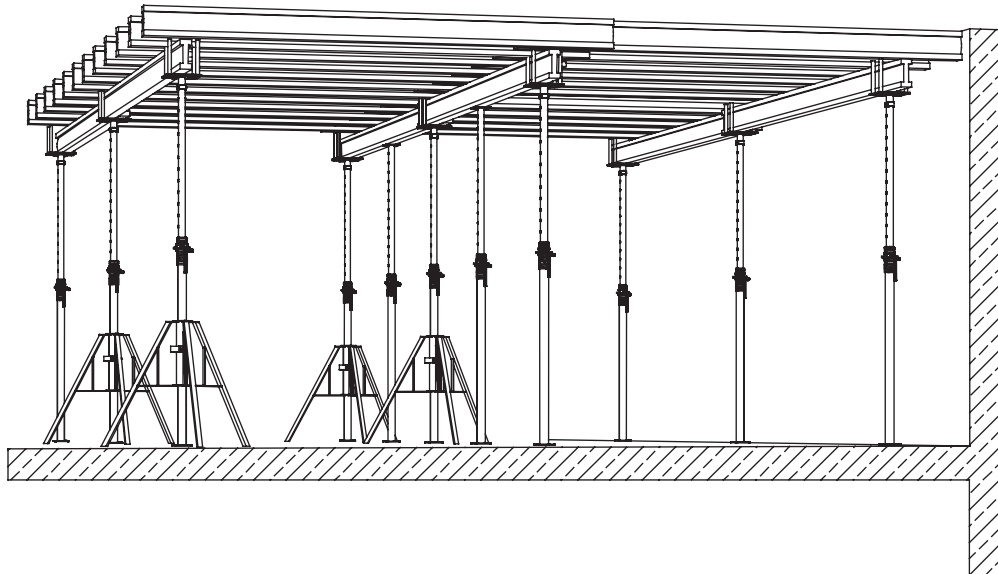

Dimensions and Tolerances

Dimensions	H20	Tolerances
Beam height (mm)	200	+/- 2 mm
Chord height (mm)	40	- 1,5 %
Chord width (mm)	80	- 1,5 %
Web thickness (mm)	26,8	+/- 0,5 mm

these values apply at a wood moisture content of 12 %

	H20
Permissible modulus M [kNm]	5,0
Permissible shearing force Q [kN]	11,0
Section modulus <sup>1)</sup> W <sub>x</sub> [cm <sup>3</sup> ]	461
Geometrical moment of inertia <sup>1)</sup> J <sub>x</sub> [cm <sup>4</sup> ]	4613

<sup>1)</sup> The values of the section modulus and the geometrical moment of inertia apply to new or used concrete formwork beams. An analogously increased factor of safety needs to be added for severely worn beams.

Beam

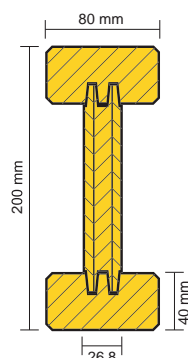

Quick Lowering Mechanism

Another special feature is that all the props are equipped with the patented quick-release bolt, which, with a blow of the hammer, immediately releases the adjustment nut.

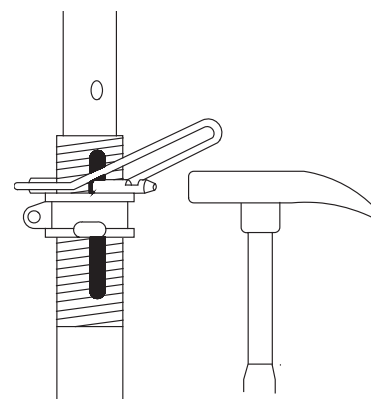

Practical accessory items make Slabflex soft t formwork faster and more efficient. The tripod stand makes it easier to erect the props.

Striking is made easier by lowering the shuttering plane by about 6 cm using the adjustment nut of the steel props.

Method of Statement

**Prop with fork head**

To begin with, the fork heads 8/20 have to be attached to the steel props. Both fork heads have a 2-way design. This means that in one position one timber beam, and in the other position - a 90° rotation - two timber beams can be inserted in the head

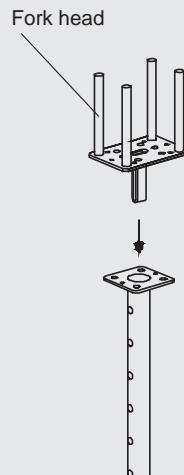

**Prop with tripod stand**

The tripod stand makes it easier to set up the tubular steel props during erection. The tripod stand can be used with all types of props. The flexibly mounted supporting legs of the tripod stand permit an optimal fit, even in the corners of the structure.

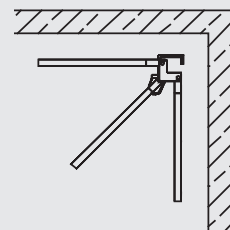
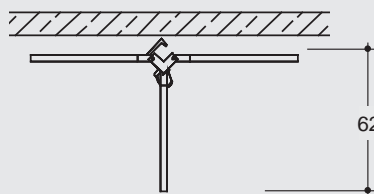
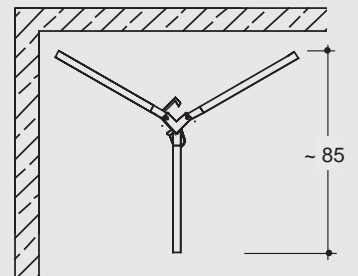
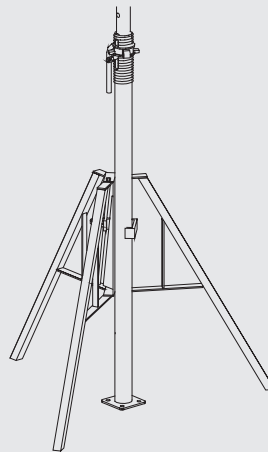

**Important note:**

After the soffit formwork has been completely erected in the room or area, the tripod stand can be removed and shifted to the next erection site. It serves only as an aid in assembling the slab formwork. The tripods stand can be folded up to save space.

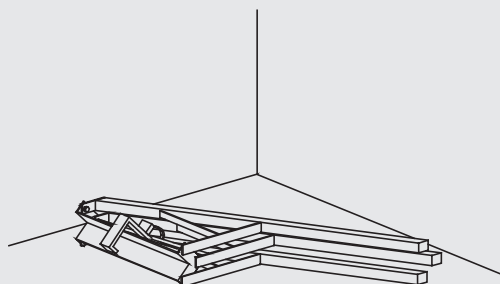

## Method of Statement

### Erecting the primary beams

Erection of the Slabflex soffit formwork begins with setting up the primary beams. For this, the props are set at roughly the required extension length on the ground. The fork heads are mounted to them, and then they are set up under the ends of the primary beams (in the case of jointed beams, under the joints as well). To keep them steady, tripod stands are attached to these props.

Following this, the H20 beams are placed in the fork heads of the props. The assembly forks make this step much easier.

Then the remaining props should be set up, taking into account the static requirements and design calculation. (room height, slab thickness, and maximum permitted loading capacity of the tubular steel props which are being used).

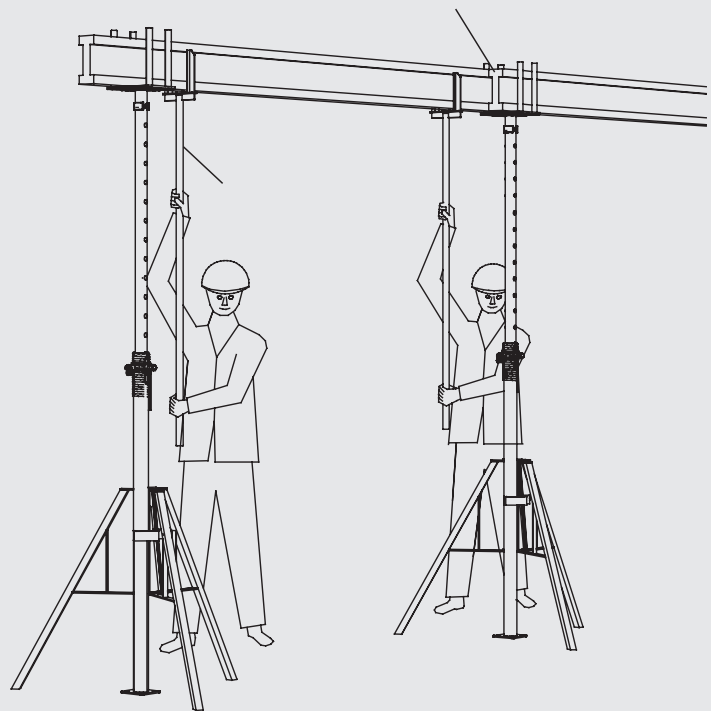

## Method of Statement

### Placing the secondary beams

The correct distance between the secondary beams must be calculated, in line with the static requirements, by using the loading tables on this manual. A beam must be placed under each shuttering panel joint. The work is facilitated by the assembly fork.

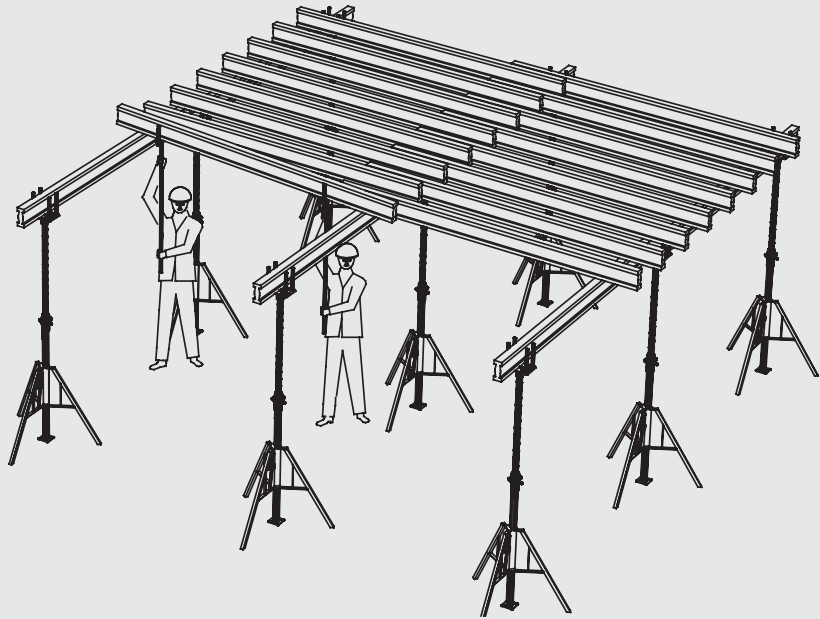

Placing the secondary beams

### Adding the shuttering panels

The shuttering panels are placed on top of the secondary beams and tacked in place. The rigid shuttering structure must be braced against the building.

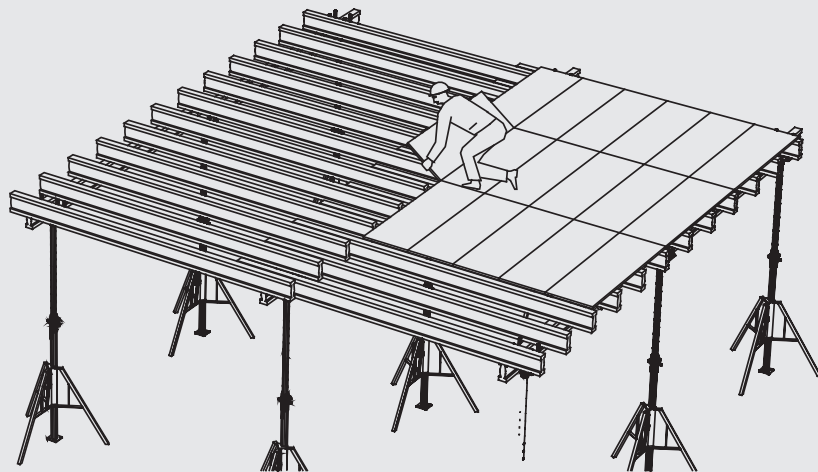

Adding the shuttering skins

### Notes:

Safety rails must be erected on the edges of the structure, in line with the regulations for safety and health protection in shuttering and scaffolding or the safety plan for which the application is taking place.

# Method of Statement

## Shuttering procedures

- A. Secure fork head or drophead in the props.
- B. Set up tripod stands (at least 4 in the corners of the room, plus additional units for primary beam joints)
- C. Secure the props in the tripod stands.
- D. Lay the primary beams in the fork heads
- E. Attach additional props and steel prop hangers.
- F. Lay secondary steel prop hangers.
- G. Lay shuttering panels.

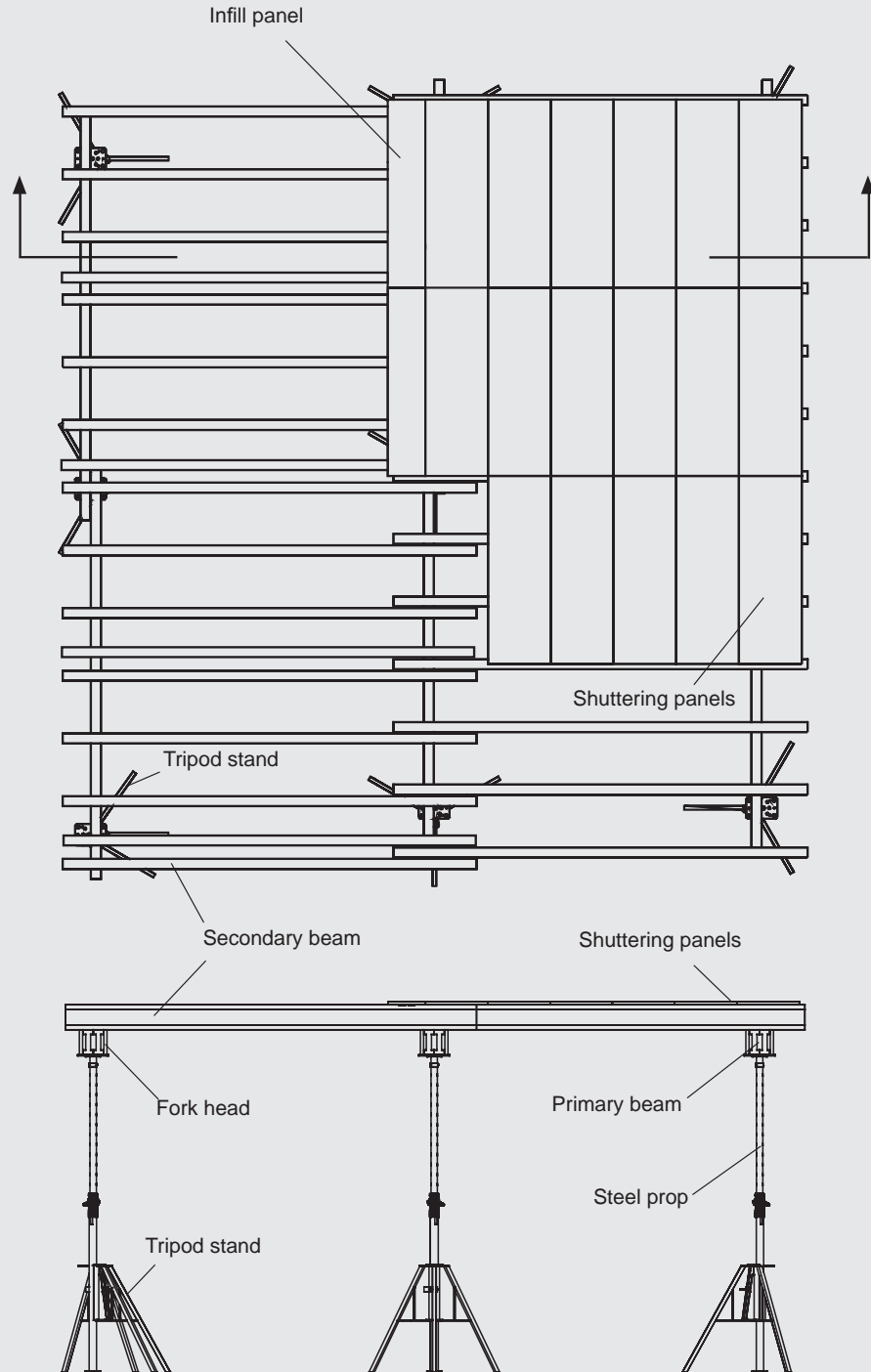

# Method of Statement

Stripping begins with lowering the props. For all steel props from EWST, release bolts immediately to reduce the pressure on the thread nut. Slightly hammer suffices and then the slab shuttering can easily be lowered by about 6 cm turning down the adjustment nut.

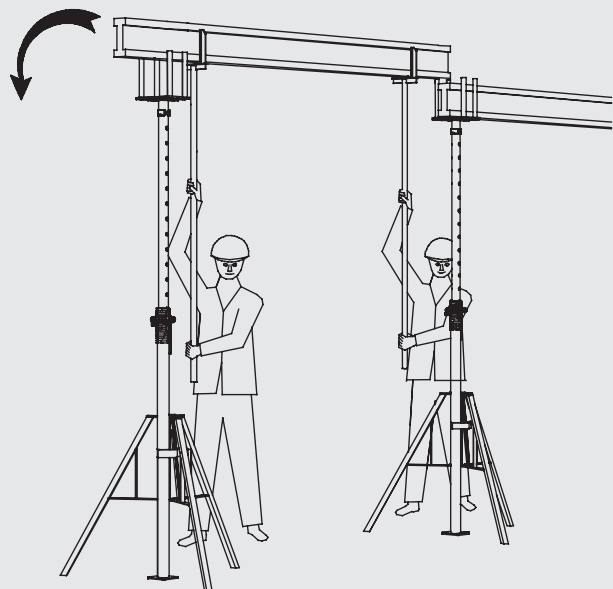
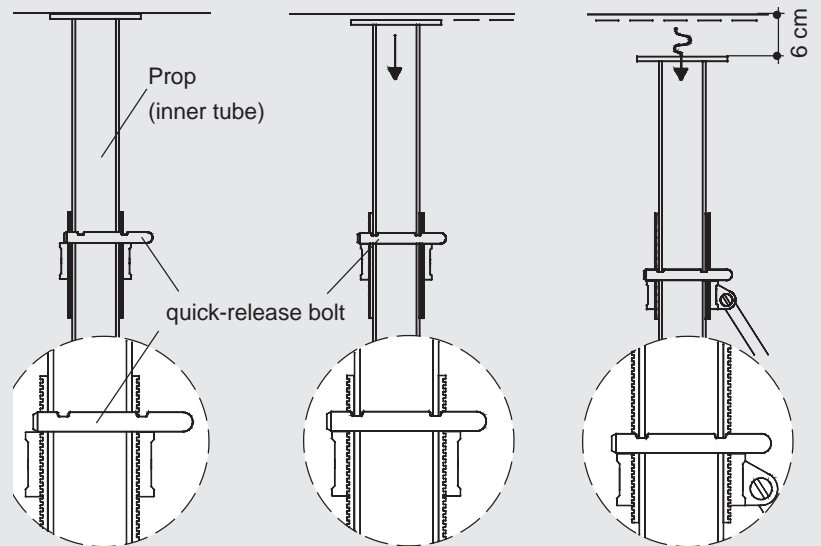
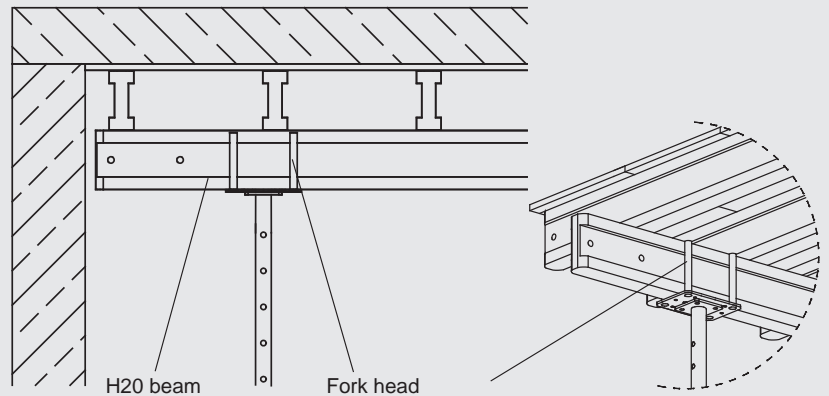

The assembly fork is an effective tool for taking down the primary beams. Remove the tripod stands from the props, and sort and stack all of the shuttering materials.

# Design Guidelines

## Erecting the primary beams

The existing slab thickness and the selected secondary beam spacing, which depends upon the type and size of the selected shuttering panel, determine the maximum permitted distance between primary beams.

Using the selected primary beam spacing and slab thickness, the maximum permitted distance between props for the primary beams can then be determined.

All the figures necessary for the efficient use of Slabflex soffit formwork can be quickly determined with the help of the following tables.

### Overall view: Slab flex

#### Cantilever:

$K = 0.2 \cdot L$   
max.  $K = 0.50 \text{ m}$

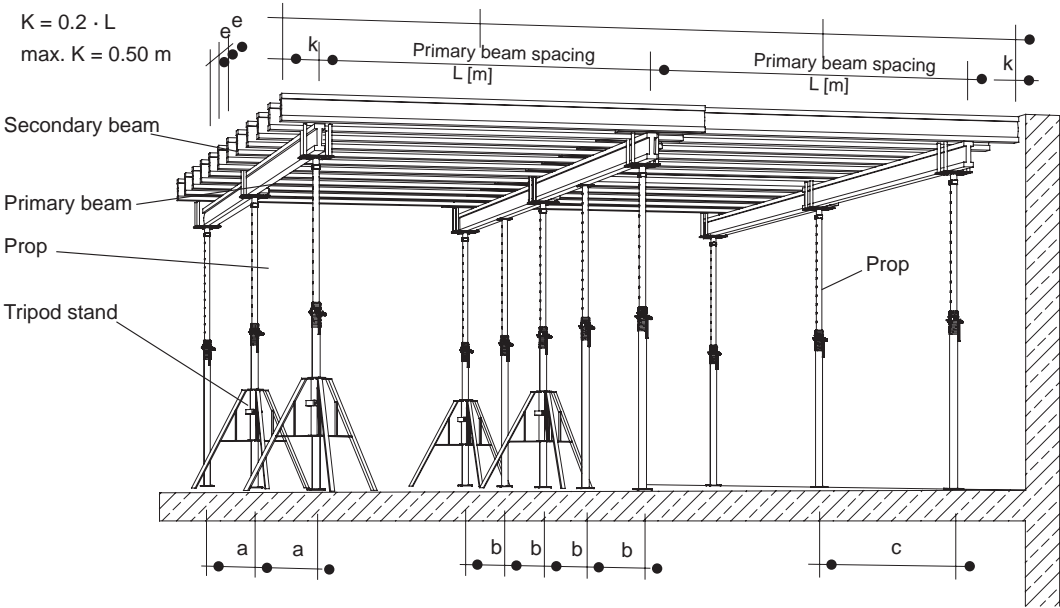

### Support spacing for shuttering panels

EWST will issue calculation determining the primary, secondary, props spaces and quantity for each specific slab geometry

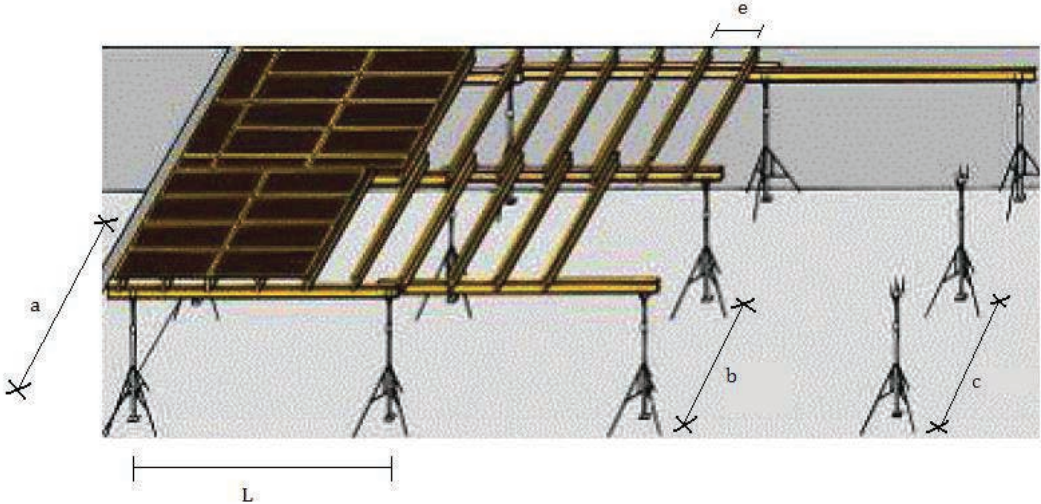

# Load tables for H20

## Permissible distances between main beams and supports

- Max. deflection: 1/500
- Live load: 1.5kN/m<sup>2</sup> or 20% of concrete weight
- permissible carrying force of the support: min. 22 kN
- Technical Specifications: permissible moment = 5.0 kNm permissible surface load (q) = 11.0 kN

Floor thickness (cm)	Total Load kN/m <sup>2</sup>	Table 1: Crossbeams				Table 2: Main beams								
		Distance between crossbeams (m)				Selected distance between the main beams (m)								
		0.50	0.625	0.667	0.75	1.00	1.25	1.50	1.75	2.00	2.25	2.50	3.00	3.50
		Max. permissible support width of the cross beam = max. distance between main beams				Max. permissible support width = distance between supports								
10	4,35	3,67	3,40	3,33	3,20	2,91	2,70	2,48	2,29	2,14	2,02	1,92	1,69	1,44
12	4,87	3,47	3,22	3,15	3,03	2,75	2,55	2,34	2,17	2,03	1,91	1,81	1,51	1,29
14	5,39	3,30	3,07	3,00	2,89	2,62	2,43	2,22	2,06	1,93	1,81	1,63	1,36	1,17
16	5,91	3,17	2,94	2,88	2,77	2,52	2,33	2,12	1,97	1,84	1,65	1,49	1,24	1,06
18	6,43	3,05	2,83	2,77	2,67	2,42	2,23	2,04	1,89	1,71	1,52	1,37	1,14	0,98
20	6,95	2,95	2,74	2,68	2,58	2,34	2,15	1,96	1,81	1,58	1,41	1,27	1,06	0,90
22	7,47	2,86	2,66	2,60	2,50	2,27	2,07	1,89	1,68	1,47	1,31	1,18	0,98	0,84
24	7,99	2,79	2,59	2,53	2,43	2,21	2,00	1,83	1,57	1,38	1,22	1,10	0,92	0,79
26	8,51	2,72	2,52	2,47	2,37	2,16	1,94	1,72	1,48	1,29	1,15	1,03	0,86	0,74
28	9,03	2,65	2,46	2,41	2,32	2,10	1,88	1,62	1,39	1,22	1,08	0,97	0,81	0,70
30	9,61	2,59	2,41	2,36	2,27	2,04	1,82	1,53	1,31	1,14	1,02	0,92	0,76	0,65
35	11,17	2,47	2,29	2,24	2,16	1,89	1,58	1,31	1,13	0,98	0,88	0,79	0,66	0,56
40	12,73	2,36	2,19	2,15	2,05	1,73	1,38	1,15	0,99	0,86	0,77	0,69	0,58	0,49
45	14,29	2,27	2,11	2,05	1,93	1,54	1,23	1,03	0,88	0,77	0,68	0,62	0,51	0,44
50	15,85	2,20	2,01	1,95	1,83	1,39	1,11	0,93	0,79	0,69	0,62	0,56	0,46	0,40
55	17,41	2,13	1,92	1,86	1,68	1,26	1,01	0,84	0,72	0,63	0,56	0,51	0,42	0,36
60	18,97	2,05	1,84	1,74	1,55	1,16	0,93	0,77	0,66	0,58	0,52	0,46	0,39	0,33
65	20,53	1,97	1,71	1,61	1,43	1,07	0,86	0,71	0,61	0,54	0,48	0,43	0,36	0,31
70	22,09	1,90	1,59	1,49	1,33	1,00	0,80	0,66	0,57	0,50	0,44	0,40	0,33	0,28
75	23,65	1,84	1,49	1,40	1,24	0,93	0,74	0,62	0,53	0,47	0,41	0,37	0,31	0,27
80	25,21	1,75	1,40	1,31	1,16	0,87	0,70	0,58	0,50	0,44	0,39	0,35	0,29	0,25
85	26,77	1,64	1,31	1,23	1,10	0,82	0,66	0,55	0,47	0,41	0,37	0,33	0,27	0,23
90	28,33	1,55	1,24	1,16	1,04	0,78	0,62	0,52	0,44	0,39	0,35	0,31	0,26	0,22
95	29,89	1,47	1,18	1,10	0,98	0,74	0,59	0,49	0,42	0,37	0,33	0,29	0,25	0,21
100	31,45	1,40	1,12	1,05	0,93	0,70	0,56	0,47	0,40	0,35	0,31	0,28	0,23	0,20

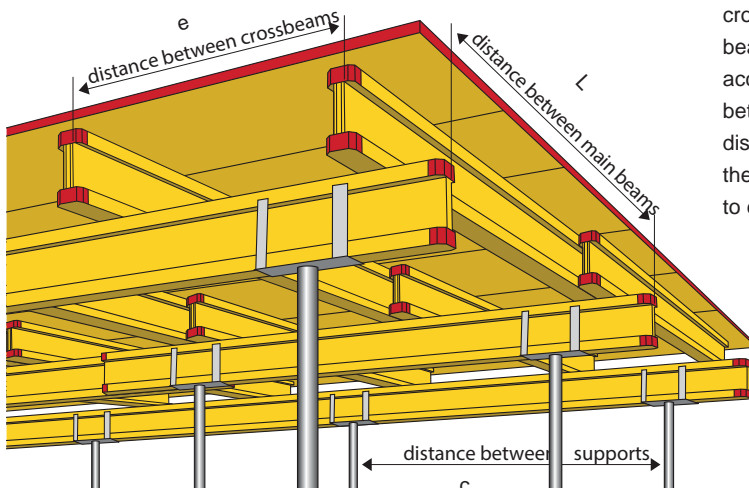

Example of calculation: Ceiling strength: **20 cm**, distance between crossbeams: **75 cm**; we are looking for the distance between main beams and supports: permissible distance between main beams according to table 1 = **2,58 m**. The identical or next smaller distance between main beams in table 2 = **2,5 m**. Look for the permissible distance between supports in table 2, in column 2,5 depending on the ceiling strength (20 cm) = **1,27 m**. Caution! Examine the supports to ensure the corresponding carrying force.

# Load tables for prop

## Appendix 1:

**Galv. steel props**  
**20-250, 20-300, 20-350, 20-400, 20-500 and 20-550**  
 Permissible prop loads always 20 kN minimum

**20 kN**

Permissible prop loads [kN] for use in system-bound arrangement

Designation Lmin. – Lmax. Position of Inner Tube (IT) L[m]	20-300 1.72m-3.00m		20-350 1.98m-3.50		20-400 2.24m-4.00m		20-500 2.71m-5.00m		20-550 3.04m-5.50m	
	I.T. @ Top	I.T. @ Bottom	I.T. @ Top	I.T. @ Bottom	I.T. @ Top	I.T. @ Bottom	I.T. @ Top	I.T. @ Bottom	I.T. @ Top	I.T. @ Bottom
1.40										
1.50										
1.60										
1.70										
1.80	38.48	38.48								
1.90	38.48	38.48								
2.00	35.09	38.48	27.76	27.76						
2.10	32.52	38.48	27.76	27.76						
2.20	30.91	38.48	27.76	27.76						
2.30	29.30	38.48	27.76	27.76	30.97	30.97				
2.40	28.01	38.48	27.76	27.76	30.97	30.97				
2.50	27.21	38.48	27.76	27.76	30.97	30.97				
2.60	26.40	35.55	27.76	27.76	30.97	30.97				
2.70	25.44	32.42	27.76	27.76	30.97	30.97	38.48	38.48		
2.80	23.83	29.69	27.76	27.76	30.97	30.97	38.48	38.48		
2.90	22.22	26.95	27.76	27.76	30.97	30.97	38.48	38.48		
3.00	20.61	24.21	27.76	27.76	30.97	30.97	38.48	38.48		
3.10			27.76	27.76	30.97	30.97	38.48	38.48	38.48	38.48
3.20			27.76	27.76	30.97	30.97	38.48	38.48	38.48	38.48
3.30			27.19	27.76	30.97	30.97	38.48	38.48	38.48	38.48
3.40			25.70	27.76	29.19	30.97	38.48	38.48	38.48	38.48
3.50			24.21	27.76	28.02	30.97	38.48	38.48	38.48	38.48
3.60					26.75	30.97	37.48	38.48	38.48	38.48
3.70					25.35	30.97	37.48	38.48	38.48	38.48
3.80					23.94	28.95	37.48	37.48	38.48	38.48
3.90					22.53	26.84	37.48	37.48	38.48	38.48
4.00					21.12	24.73	37.48	37.48	38.48	38.48
4.10							36.58	37.48	38.48	38.48
4.20							36.58	37.48	38.29	38.48
4.30							36.58	37.48	36.58	38.48
4.40							34.99	36.58	34.99	38.48
4.50							33.40	36.58	33.40	38.48
4.60							31.82	36.58	31.82	38.48
4.70							30.23	36.58	30.23	36.71
4.80							28.64	34.12	28.64	34.12
4.90							27.13	31.71	27.13	31.71
5.00							26.04	30.29	26.04	30.29
5.10									24.95	28.87
5.20									23.87	27.45
5.30									22.78	26.03
5.40									21.69	24.60
5.50									20.61	23.18

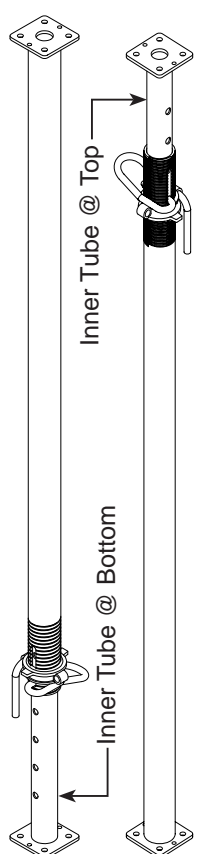

# Load tables for prop

## Appendix 2:

Galv. steel props  
 30-300, 30-350, and 30-400,  
 Permissible prop loads always 30 kN minimum

**30 kN**

Permissible prop loads [kN] for use in system-bound arrangement

Designation Lmin. – Lmax. Position of Inner Tube (IT) L[m]	30-300 1.72m-3.00m		30-350 1.98m-3.50		30-400 2.24m-4.00m	
	I.T. @ Top	I.T. @ Bottom	I.T. @ Top	I.T. @ Bottom	I.T. @ Top	I.T. @ Bottom
1.40						
1.50						
1.60						
1.70						
1.80	37.21	37.21				
1.90	37.21	37.21				
2.00	37.21	37.21	49.45	49.45		
2.10	37.21	37.21	49.45	49.45		
2.20	37.21	37.21	49.45	49.45		
2.30	37.21	37.21	49.45	49.45	38.48	38.48
2.40	36.83	37.21	48.91	49.45	38.48	38.48
2.50	36.19	37.21	47.56	49.45	38.48	38.48
2.60	35.55	37.21	46.20	49.45	38.48	38.48
2.70	34.77	37.21	44.85	49.45	38.48	38.48
2.80	33.48	37.21	43.57	48.56	38.48	38.48
2.90	32.20	37.21	42.35	47.07	38.48	38.48
3.00	30.91	36.58	41.13	45.58	38.48	38.48
3.10			39.91	44.09	38.48	38.48
3.20			37.82	41.73	38.48	38.48
3.30			35.52	39.15	38.48	38.48
3.40			33.21	36.58	38.48	38.48
3.50			30.91	34.00	38.48	38.48
3.60					38.48	38.48
3.70					38.48	38.48
3.80					38.48	38.48
3.90					37.94	38.48
4.00					36.06	38.48

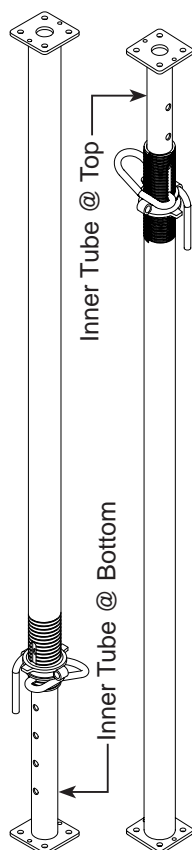

# Slab Table System

Quick & Easy System



## Product Features

H20 Slab Table formwork system consists of H20 Timber Beams, Euroform Plus Steel Galvanized Props, Table Head and Table Clamp. Together with the 18 mm thick plywood sheets, the H20 slab table is designed for concrete slabs up to 45cm thick. H20 slab tables are designed according to the structural geometry of the building and mainly used for high-rise buildings, podiums, parking and large slab areas. Horizontal movement of the tables is made manually by trolleys while vertical movement is made by crane.

Fixing the Table Heads to the H20 slab table is quite simple. It is fastened to the double primary beams by means of the Table Clamp which is a short piece of Tie Rod and Wing Nut. No drilling, no screwing and no special tools are needed.

The H20 Slab Table Formwork System is designed and manufactured in accordance with BS EN 12812 : 2008, code of practice for Falsework

## Important notes:

All information provided about maximum loads are only valid for horizontally braced slab table arrangements which are secured against existing structural building parts such as columns, shear and core walls.

The system does not allow transfer of any horizontal loads thru the Euroform Plus steel props of the table system to the ground or floor slab. The top structure of the slab table has to be braced and secured horizontally by adequate measures against existing structural concrete parts by means of wedging or any kind of bracing to walls or columns.



After positioning and securing the H20 slab table, the Euroform Plus steel props have to be aligned vertically in order to avoid any moment coming in to the steel prop. Eccentric as well as big loads have to be avoided because the Euroform Plus steel props are designed to take centric and/or symmetrical loads only.

# Overview

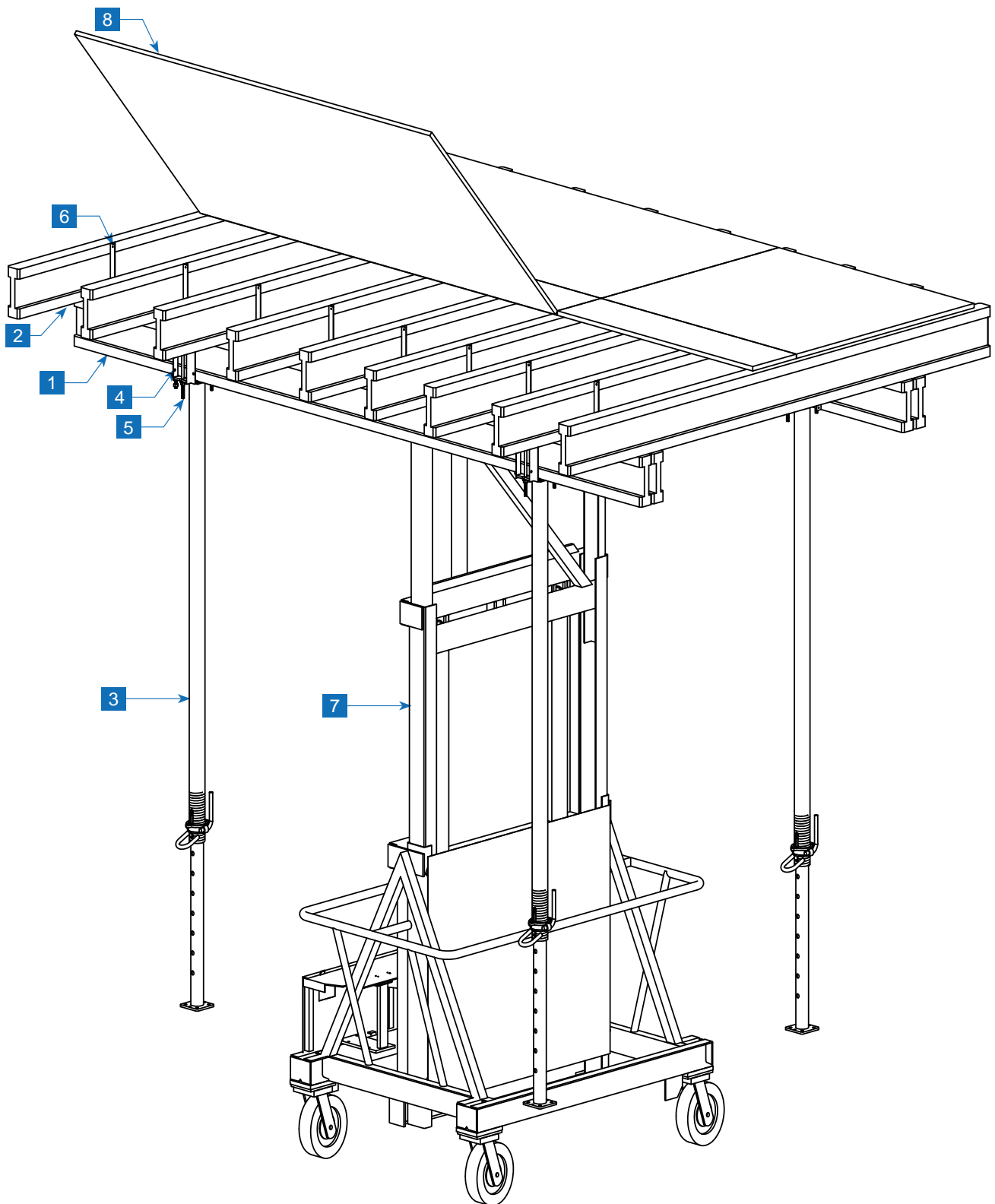

1. H20 Primary Beam
2. H20 Secondary Beam
3. Steel Prop
4. Table Head
5. Table Clamp
6. Connection Angle
7. Shifting Trolley
8. Plywood

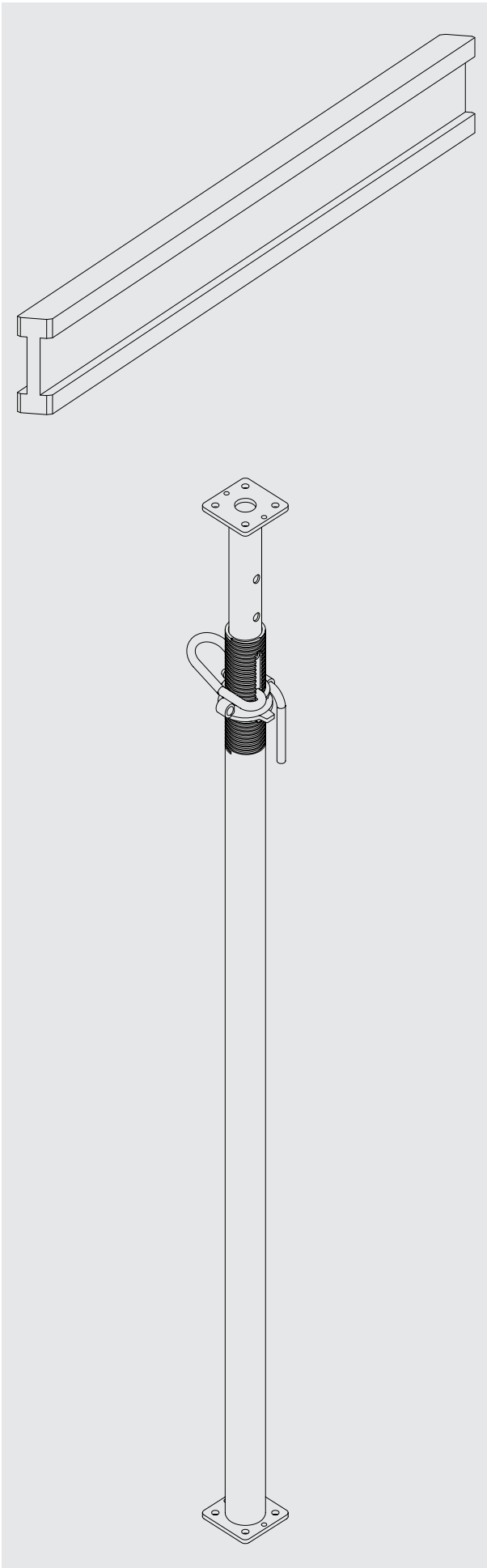

**Description**

**Art. No**

**Weight**

**H20 Timber Beam**

With End cap protection

H20 - Timber Beam 2.00	0000018	9.20
H20 - Timber Beam 2.45	0000002	11.27
H20 - Timber Beam 2.65	0000003	12.19
H20 - Timber Beam 3.00	0000016	13.80
H20 - Timber Beam 3.30	0000005	15.18
H20 - Timber Beam 3.60	0000006	16.56
H20 - Timber Beam 3.90	0000007	17.94
H20 - Timber Beam 4.50	0000008	20.70
H20 - Timber Beam 4.90	0000009	22.54
H20 - Timber Beam 5.50	0000014	25.30
H20 - Timber Beam 5.90	0000010	27.14

**Steel Prop**



The inner and outer tubes, including the threads, are hot-dip galvanized steel which ensure the quality and high durability of tubular steel props. EWST

**20kN Prop**

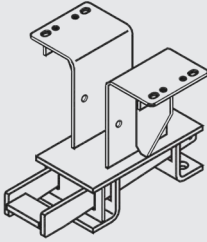
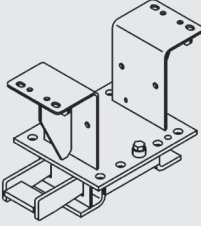
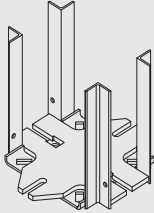
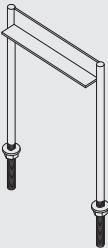
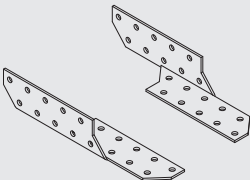

Galv. Prop 20-260 (L=1.54 - 2.60 m)	601260	13.40
Galv. Prop 20-300 (L=1.72 - 3.00 m)	601300	16.20
Galv. Prop 20-350 (L=1.98 - 3.50 m)	601350	19.80
Galv. Prop 20-400 (L=2.24 - 4.00 m)	601400	23.70
Galv. Prop 20-500 (L=2.72 - 5.00 m)	601500	31.70
Galv. Prop 20-550 (L=3.05 - 5.50 m)	601550	38.00

**30kN Prop**

Galv. Prop 20-260 (L=1.54 - 2.60 m)	600260	15.20
Galv. Prop 20-300 (L=1.72 - 3.00 m)	600300	16.70
Galv. Prop 20-350 (L=1.98 - 3.50 m)	600350	20.70
Galv. Prop 20-400 (L=2.24 - 4.00 m)	600400	25.00

	Description	Art. No	Weight
	<p><b>Table Head 20</b></p> <p>It Can be used as Alternative for Galv. Table Head, but Single primary can be used only in Table Head 20</p>	601650	16.50
	<p><b>Table Head 30</b></p> <p>It Can be used as Alternative for Galv. Table Head.</p>	601850	18.50
	<p><b>Galv. Table Head</b></p> <p>The Table Head is directly fastened to the base or head plate of the Steel prop by means of 2 Bolts M12x30 with Nut.</p>	601104	3.10
	<p><b>Table Clamp</b></p> <p>used as a fixing device for primary beams. it is placed into the Table Head and ensure a tension resistant connection to the steel prop</p>	660660	0.60
	<p><b>Rafter Plate</b></p> <p>Rafter Plate Right</p> <p>Rafter Plate Left</p> <p>Used for connecting primary and secondary beams of the Table</p>	601108 601109	0.09 0.09
	<p><b>Connecting Angle</b></p> <p>Used for connecting primary and secondary beams of the Table using Double-headed nails</p>	601107	0.60

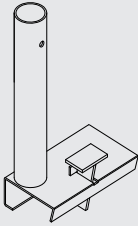
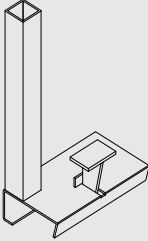
**System Components**

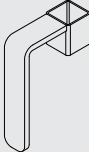
	Description	Art. No	Weight
	<p><b>Timber Beam Attachment-C</b></p> <p>The Timber Beam Attachment C is fixed by Wedge and serves as the holding device for the Railing Post C and as an alternative to Bolt Socket C.</p>	660663	3.20
	<p><b>H20 Base Shoe SQ</b></p> <p>It is fixed on the H20 Timber beam by Wedge and serves as the holding device for Safety Post</p>	660662	3.20
	<p><b>Railing Post</b></p> <p>To be placed into the general railing device.</p>	600221	3.20
	<p><b>Safety Post</b></p> <p>Inserted in the H20 base shoe and serves as guard rail to prevent falls.</p>	601110	3.15
	<p><b>Toe Board Retainer</b></p> <p>Slipped on the Railing Post before inserting it into the H20 Base Shoe. the Toe Board Retainer secures and positions the Toe Board.</p>	660665	0.50

## System Components

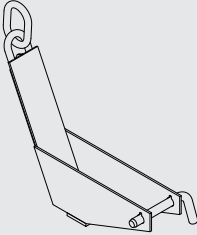
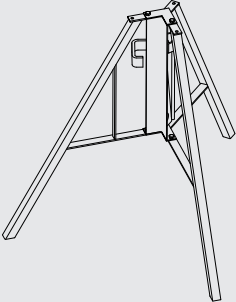
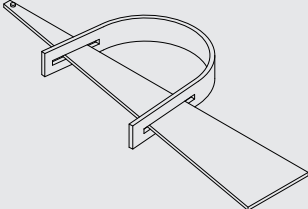
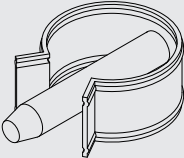
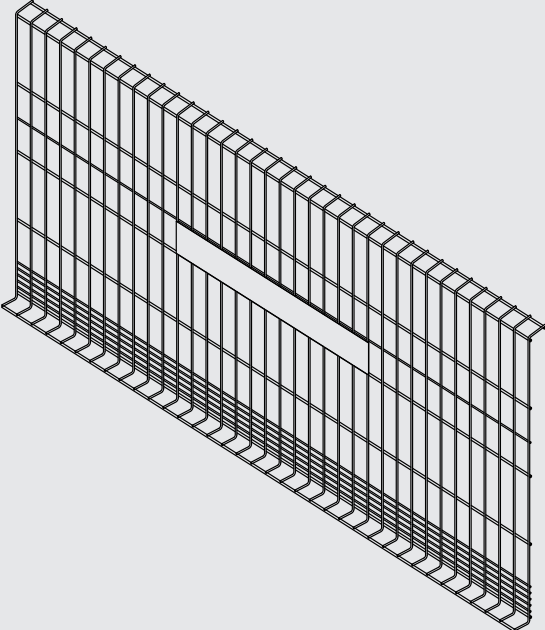
	Description	Art. No	Weight
	<p><b>Crane Hook</b></p> <p>Four crane hooks have to be always fixed to the primary beams ends for lifting the table.</p>	660664	7.10
	<p><b>Galv. Tripod</b></p> <p>For easy and quick erection of the prop for slab formwork assembly used.</p>	601100	11.60
	<p><b>Bracing Clamp</b></p> <p>Provides stiffening by means of shutter boards to any tubular steel prop.</p>	601108	1.40
	<p><b>T-Bolt</b></p> <p>Used for fixing and securing the Fork Head to the Inner Tube of the steel props.</p>	660661	0.15
	<p><b>EWST Mesh</b></p> <p>Used for temporary edge protection as an alternative to board railing</p>	601111	20.20

**System Components**

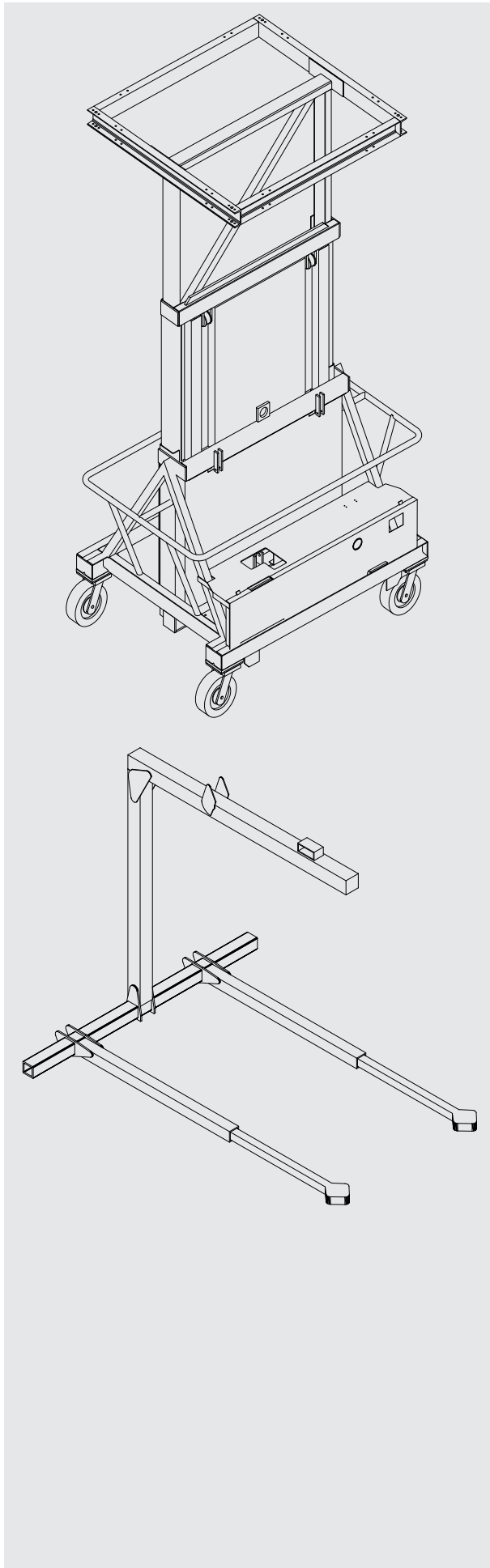

Description

Art. No

Weight

Shifting Trolley Height: 154 - 303 cm

601109

566.00

The H20 slab table can be moved horizontally using the Table Shifting Trolley. For safe moving and lifting of the H20 slab table, the table shifting Carriage has to be positioned at the center, underneath the H20 slab table to be dismantled

H20 C-Hook

660810

810

Using for carrying and moving H20 slab tables on the construction site by crane. The H20 C-Hook has a maximum load capacity of 1.2 Tons (12 kN) and is simply attached to the H20 slab table

# Top Deck

Aluminum Panel System for slab



## Product Features

The Alu Top Deck slab formwork system is made of aluminum frame panels which consist of 2 fundamental components: panels and props. The aluminum frame panels are light, durable, and easy to handle.

The multi-layer plywood sheet with a thickness of 10 mm is inserted into the aluminum profile, therefore all around edge is protected.

The Alu Top Deck system can be used with all types of Euro Plus steel props.

The system has to be braced at the panel levels against existing structural parts such as walls, columns etc.

Safe erection and dismantling of the system is also one advantage in using Alu Top Deck. For comfort and safety, a small movable scaffolding should be used for fixing the panels if height is above 3.50 m.

Due to simple use of the system, only a very short period of time is needed for getting familiarized with it. Even workers unfamiliar with the system can easily reach shuttering times between 0.15 up to 0.25 man hours per square meter.

The Alu Top Deck Formwork System is designed and manufactured in accordance with BS EN 12812 : 2008, code of practice for Falsework



### Using Standard Panel

1. The standard panel range is designed for nearly all types of ground plans and can be used for slab thickness of up to 50 cm without additional systematical support.
2. The extreme light panel weight of only 20.9 kg makes the handling of the system simple and easy.
3. The erection of the system is supported by an Alu Erection Rod which serves as an erection aid. In general, 3 to 4 workers are sufficient to erect the Alu Top Deck panel system of a normal ground plan of up to 3.8 m height.
4. The efficiency of the system allows shuttering times (erection and dismantling) of less than 0.3 man hour/m<sup>2</sup>, even with unskilled labour

# Overview

1. Aluminum Topdeck panel
2. Alu Top Deck Bearing
3. T-Bolt
4. Steel Prop
5. Prop Retainer
6. Tripod
7. Safety Multiple Clamp
8. Safety Post
9. Toe Board Retainer

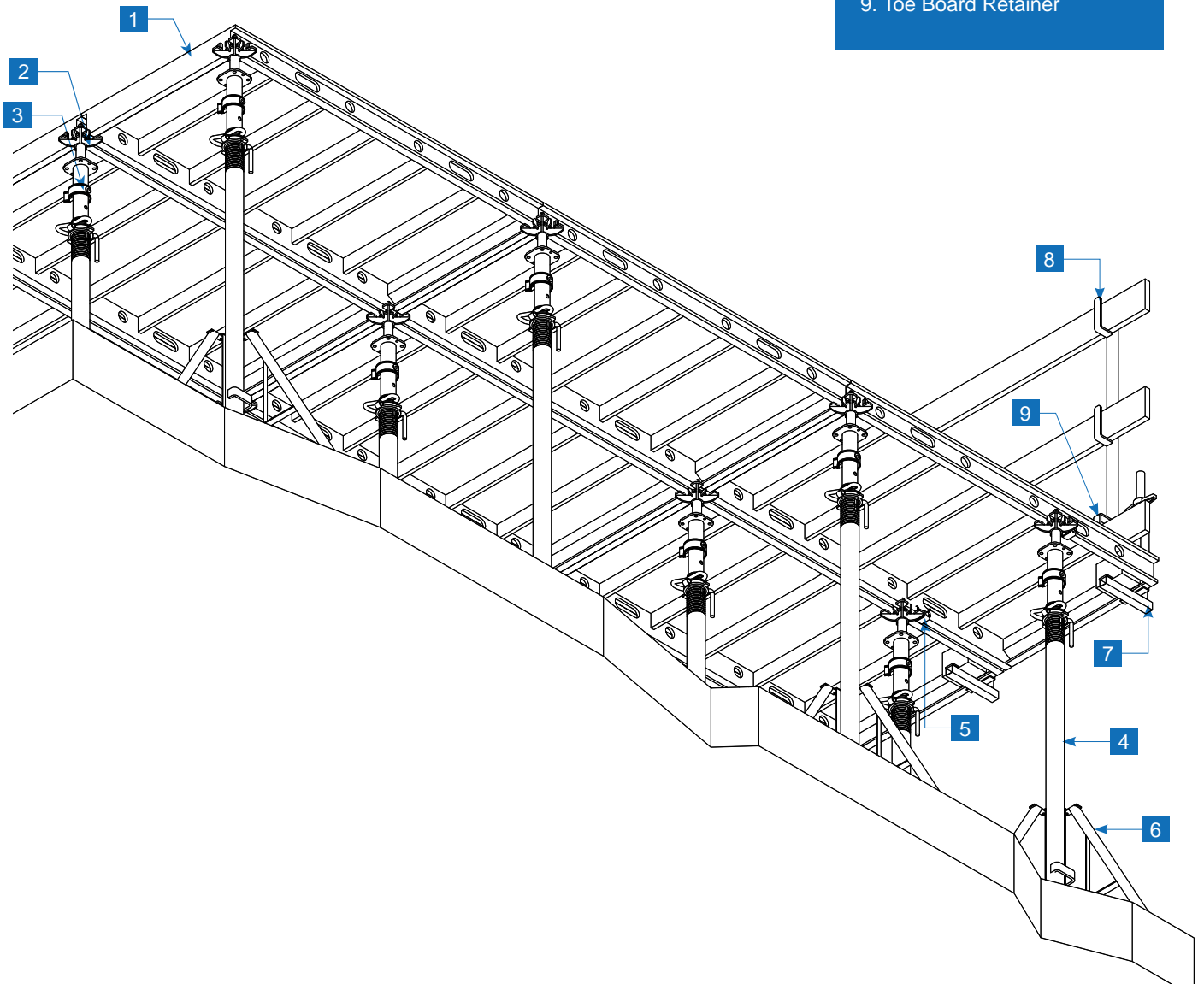

Description	Art. No	Weight
-------------	---------	--------

Topdeck Panel (Powder Coated)

Top Deck Panel 90x90	500104	12.00
Top Deck Panel 90x45	500105	8.20
Top Deck Panel 180x45	500106	14.20
Top Deck Panel 180x90	500107	22.40
Top Deck Panel 180x180	500108	48.20

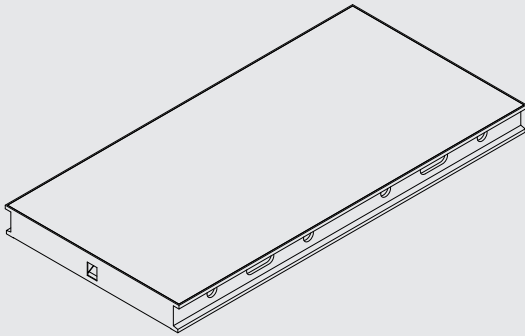

Steel Prop

The inner and outer tubes, including the threads, are hot-dip galvanized steel which ensure the quality and high durability of tubular steel props. EWST

20kN Prop

Galv. Prop 20-260 (L=1.54 - 2.60 m)	601260	13.40
Galv. Prop 20-300 (L=1.72 - 3.00 m)	601300	16.20
Galv. Prop 20-350 (L=1.98 - 3.50 m)	601350	19.80
Galv. Prop 20-400 (L=2.24 - 4.00 m)	601400	23.70
Galv. Prop 20-500 (L=2.72 - 5.00 m)	601500	31.70
Galv. Prop 20-550 (L=3.05 - 5.50 m)	601550	38.00



30kN Prop

Galv. Prop 20-260 (L=1.54 - 2.60 m)	600260	15.20
Galv. Prop 20-300 (L=1.72 - 3.00 m)	600300	16.70
Galv. Prop 20-350 (L=1.98 - 3.50 m)	600350	20.70
Galv. Prop 20-400 (L=2.24 - 4.00 m)	600400	25.00

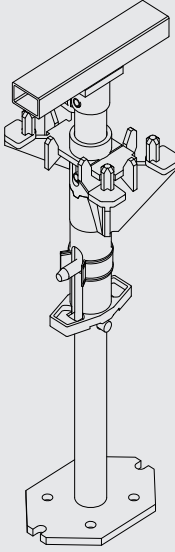
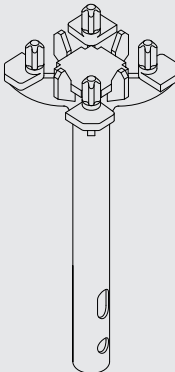
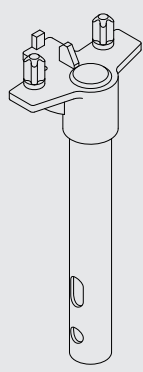
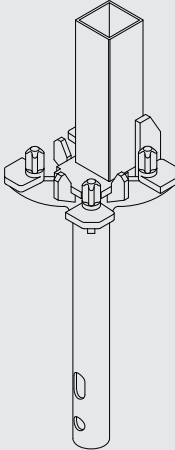

**System Components**

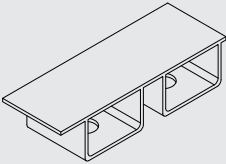
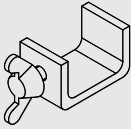
	Description	Art. No	Weight
	<p><b>Drop Head</b></p> <p>The Table Head is directly fastened to the base or head plate of the Steel prop by means of 2 Bolts M12x30 with Nut. It helps to de-shutter the panel by disturbing Prop</p>	500111	9.01
	<p><b>Alu Top Deck Bearing</b></p> <p>The Alu Top Deck Panel is supported by the top deck bearing which is placed into the inner tube the steel prop and fixed by means of the integrated T-Bolt or T-Bolt L</p>	500100	2.30
	<p><b>Top Deck Edge Support</b></p> <p>In order to provide a tight connection to wall or columns, the Alu Top Deck panels have to be supported by the Top Deck Edge support.</p>	500120	1.60
	<p><b>Railing Shoe</b></p> <p>Top Deck Railing is used at the edge if the slab shutter area and serves as a bearing device for the safety railing Post SQ</p>	500109	4.30

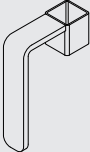
	Description	Art. No	Weight
	<p><b>Head Support Shoe</b></p> <p>This serves as support for the square timber in adjustment areas and is simply placed on top of the Top Deck Bearing</p>	500101	0.70
	<p><b>Prop Retainer</b></p> <p>The Prop Retainer is always required when the Top Deck Bearing is not positioned at the very corner of the Top Deck panels and to avoid the props from moving off its designated position when panels are arranged as cantilever.</p>	500119	0.13
	<p><b>EWST Railing Post</b></p> <p>To be placed into the general railing device.</p>	600221	3.20
	<p><b>Safety Post</b></p> <p>Inserted in the H20 base shoe and serves as guard rail to prevent falls.</p>	601110	3.15
	<p><b>Toe Board Retainer</b></p> <p>Slipped on the Railing Post before inserting it into the H20 Base Shoe. the Toe Board Retainer secures and positions the Toe Board.</p>	660665	0.50

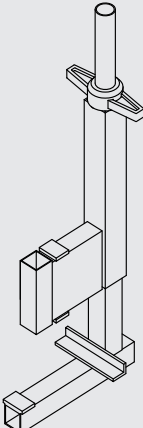
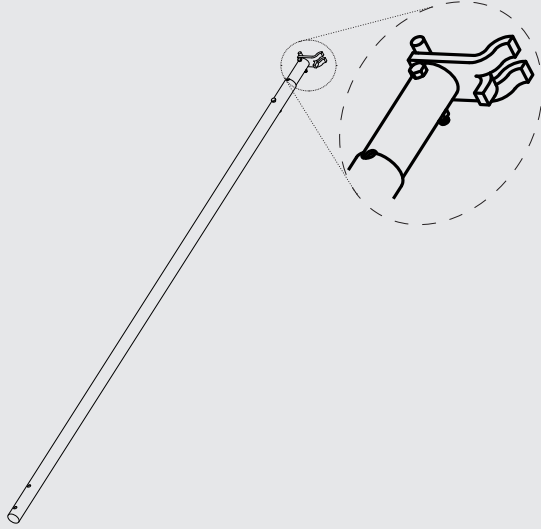
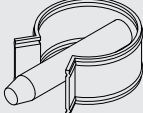
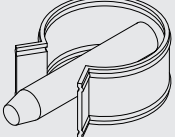
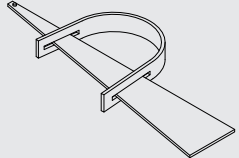
	Description	Art. No	Weight
	<p><b>Safety Multiple Clamp</b></p> <p>Used as a common holding device for the safety railing post SQ. It can be fixed to various structural parts made of steel or timber. Slab edge, roof parapets or parapets. The whole range of the multiple clamp is 1 to 47cm and by simply turning its movable jaw, the grip of the clamp can be adjusted</p>	602100	7.50
	<p><b>Alu Erection Rod</b></p> <p>The Alu Erection Rod with an extension rate from 2.00m up to 3.65 m is used as an erection aid and also for dismantling the Alu Top Deck panels for clear heights up to 3.65 m. For easy adaptation, the Alu Erection Rod can be extended in steps of 5 cm.</p> <p>For the erection of the panel system with clear heights of up to 5.40 m, the Alu Erection Rod can be extended by means of a Rod Extension 1.80 m. In this case, the Alu Erection Rod can be extended from 3.60 m up to 5.40 m.</p>	500118	4.70
	<p><b>T-Bolt</b></p> <p>Used for fixing and securing the Fork Head to the Inner Tube of the steel props.</p>	660661	0.13
	<p><b>T-Bolt-L</b></p> <p>Used for fixing and securing the Fork Head to the Inner Tube of the steel props 400, 500 and 550.</p>	500103	0.23
	<p><b>Bracing Clamp</b></p> <p>Provides stiffening by means of shutter boards to any tubular steel prop.</p>	601108	1.40

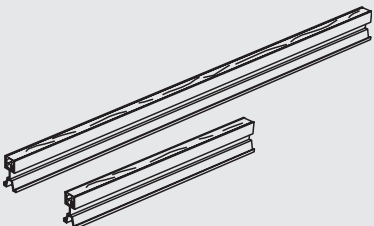
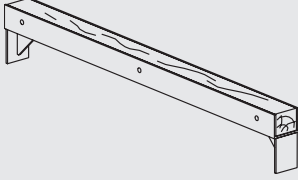
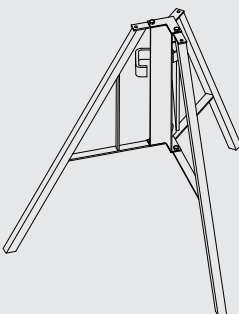
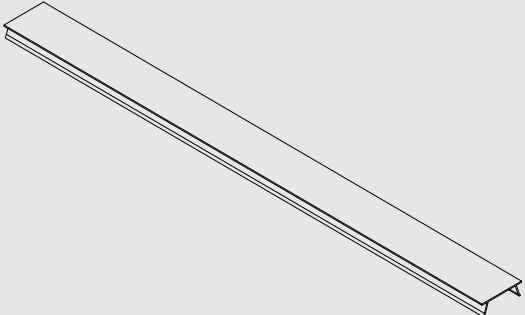
	Description	Art. No	Weight
	<p>Alu. Adjustable Beam 90 Alu. Adjustable Beam 180</p> <p>Aluminium beam with 12 cm construction height and incorporated nailable timber lath. It is laid on the Topec bearing beside the panel and supports the 21 mm thick adjustment shuttering skin.</p>	<p>500112 500113</p>	<p>3.30 6.70</p>
	<p>Transverse Beam</p> <p>This one is fitted across the adjustment beams in disturbing intersections. The end bearing plates of the transverse beam are to be placed in the grooves of the adjustment beams. It is provided with a nail-able lath. Used for 90 cm wide design.</p>	<p>500117</p>	<p>4.60</p>
	<p>Galv. Tripod</p> <p>For easy and quick erection of the prop for slab formwork assembly used.</p>	<p>601100</p>	<p>11.60</p>
	<p><b>PVC Profile 1.80m</b></p> <p>It helps to infill the gap between panels while using Drop Head</p>	<p>500116</p>	<p>0.63</p>

# T-15

## Load Bearing Support Tower



### Product Features

The T15 Support Tower is a load bearing tower that consists of only 5 different standard components with base dimensions of 1.00m x 1.00m.

Since the Head and Base Jack's combined adjustment range exceeds 33cm grid of the frames, any tower height can be erected. All individual components are hot-dip galvanized. The dead load of a T15 support tower comes up to 42 kg/rising meter which include Head and Base Jacks.

In order to allow adaptations to inclined surface of up to 6%, the bearing plates of the Head and Base Jacks are fixed. The total adjustment range of the Head and Base Jacks is almost 60 cm.

Both vertical frames 100 and 133 require only one type of T15 Diagonal as bracing. Owing to the required assembly procedure, the same rigidity in all vertical planes of the tower is achieved by changing the position of frames

by 90° from lift to lift.

All vertical and end frames are connected by the built-in quick fastening connectors.

The post of the vertical frames consists of 48.3mm dia. tube which allows mounting of bracing by common scaffold tubes with a Rigid or Swivel Coupler 48/48. The towers may have to be stabilized by horizontal anchoring at certain levels depending on the total tower height. Details of the vertical distances for this type of stabilizing method can be taken from the relevant load tables.

The T15 Formwork System is designed and manufactured in accordance with BS EN 12812 : 2008, code of practice for Falsework



## Important Remarks

1. Easy assembly - using only 5 different components makes the assembly of the T15 support tower quick and easy. The heaviest part (Frame 133) weighs 18.9 kg only.
2. Horizontal assembly - the design of the individual components of the T15 support tower allows the assembly of the tower safely on the ground in horizontal position. The T15 support tower can be safely assembled horizontally, lifted by crane and placed into position.
3. Application alternatives - due to its versatility, the T15 support tower offers various possibilities of applications in various field of construction such as industrial, housing, bridge construction etc.
4. Combination variations - due to high flexibility of the T15 support tower, the system can be combined with additional supporting frames which are closely attached to the tower in order to transfer high loads safely into the ground. The system ensures an extremely high adaptation to all structural shapes and situations.
5. Galvanization - to ensure the high quality of the T15 support tower, all individual components are hot-dip galvanized. Due to this, cleaning and maintenance costs are considerably low.
6. Design approval - using the T15 support tower allows a maximum load-bearing capacity of up to  $4 \times 50 \text{ kN} = 200 \text{ kN}$ . The project and design related permissible vertical and horizontal loads should be taken directly from the Design calculation and drawing issued by technical department from each specification application

# Overview

- 1. T15 Base Jack
- 2. T15 End Frame
- 3. T15 Frame 133
- 4. T15 Diagonal
- 5. T15 Head Jack
- 6. Primary Beam

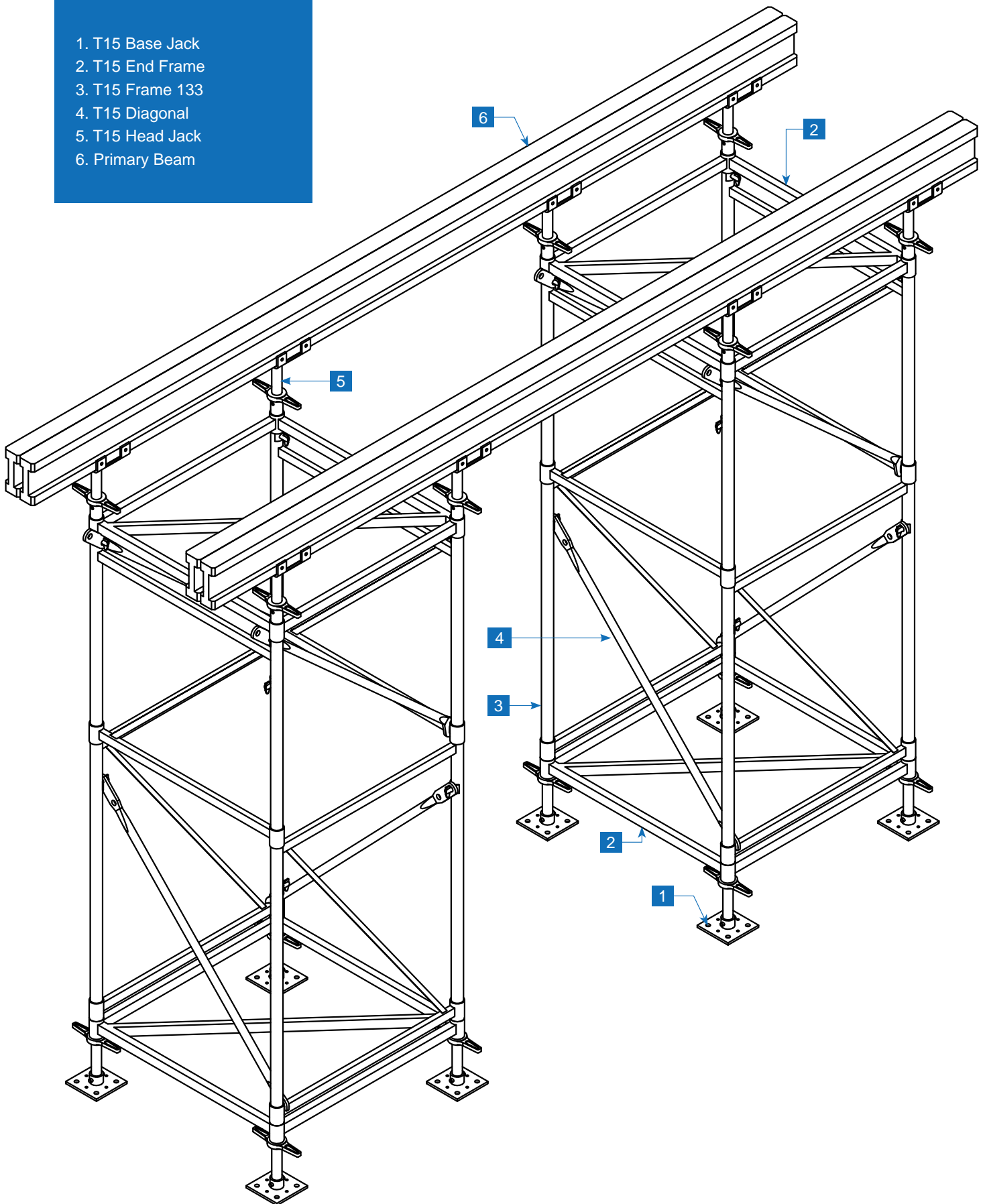

System Components

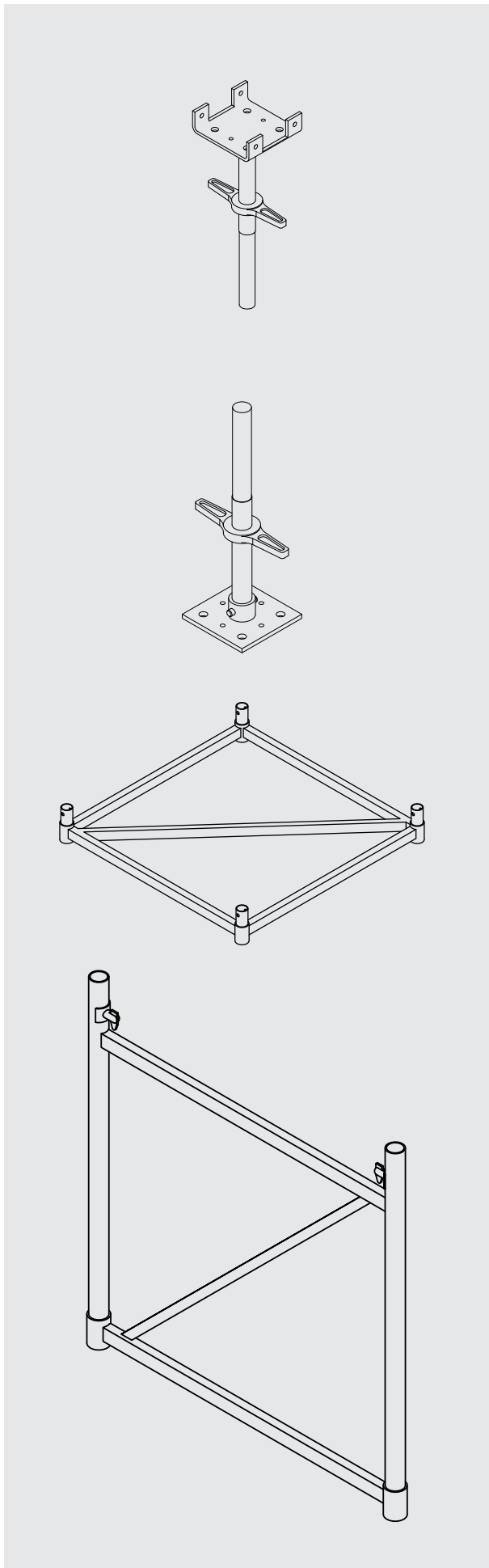

Description

Art. No

Weight

T15 Head Jack

600101

8.10

For bearing timber or steel beams. Slope of up to 6 % can be compensated by the head plate. Height adjustment: from 8 cm to 29.8 cm.

T15 Base Jack

600102

7.60

For setting-up the frame support. Slope of up to 6 % can be compensated by the head plate. Height adjustment: from 8.7 cm to 30.0 cm.

T15 End Frame 10

600103

16.40

To be assembled as sectional bracing of the frame support to ensure the square shape

T15 Frame 100

600104

15.70

The frames are tension-resistantly connected with the tightly built-in wedges of the quick-action connectors.

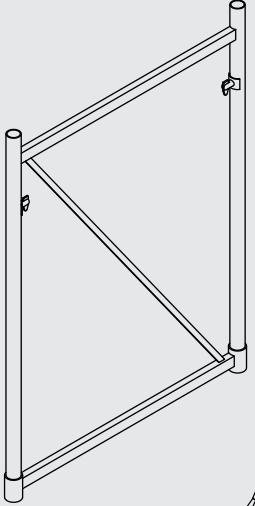
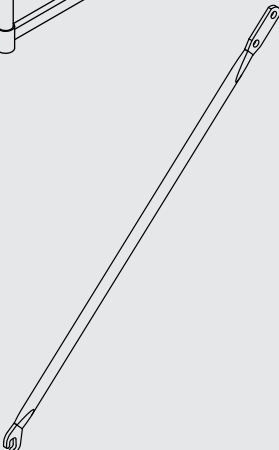
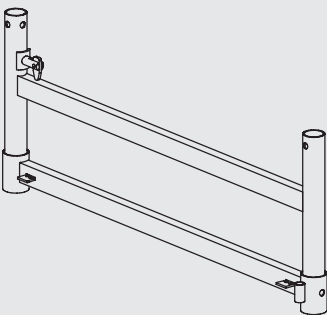
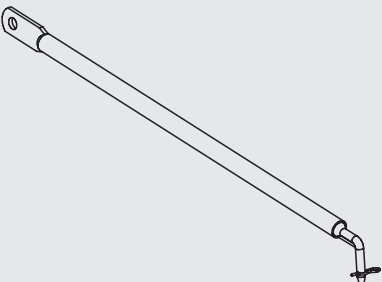
	Description	Art. No	Weight
	<p>T15 Frame 133</p>	<p>600105</p>	<p>18.90</p>
	<p>T15 Diagonal Brace</p> <p>Used for bracing both types of frame within the tower at right angles to frame plane.</p>	<p>600106</p>	<p>3.00</p>
	<p>T15 Adjustment Frame 33</p> <p>Used for height adjustment of a frame support during successive applications. It makes the complete reconstruction of a tower unnecessary. Structural height of the frame: 33.5 cm</p>	<p>600107</p>	<p>8.80</p>
	<p>T15 Diagonal 33</p> <p>Required as bracing for adjustment frame 33</p>	<p>600108</p>	<p>1.90</p>

System Components

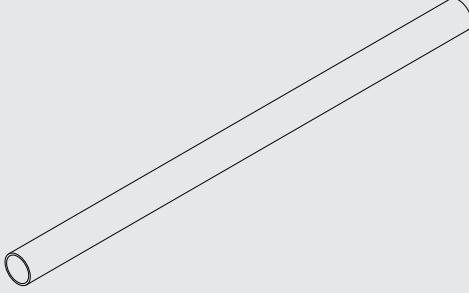
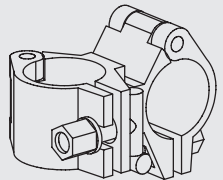
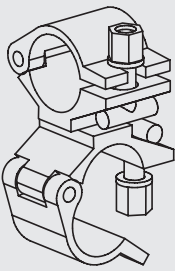
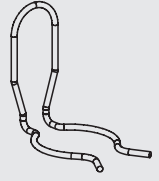
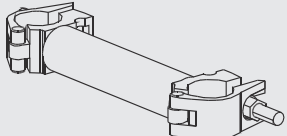
	Description	Art. No	Weight
	Scaffold Tube		
	Scaffold Tube 50 cm	602101	1.90
	Scaffold Tube 100 cm	602102	3.80
	Scaffold Tube 150 cm	602103	5.70
	Scaffold Tube 200 cm	602104	7.60
	Scaffold Tube 250 cm	602105	9.50
	Scaffold Tube 300 cm	602106	11.40
	Scaffold Tube 350 cm	602107	13.30
	Scaffold Tube 400 cm	602108	15.20
	Scaffold Tube 450 cm	602109	17.10
	Scaffold Tube 500 cm	602110	19.00
Scaffold Tube 600 cm	602111	23.00	
	Rigid Coupler	600117	1.20
	Swivel Coupler	600118	1.20
	Basejack Retainer	601990	0.10
	Frame Connector	601991	2.20

# Method of Statement

## Guidelines and Instructions

- A. Pre-assemble the T-15 support towers according to the required height combinations and the planned assembly sequence.
- B. Adjustment of the Head and Base Jacks should be done roughly to the requested extension height. The Head Jack must have enough reserve adjustment length to quickly release it from its load when dismantling the towers.
- C. For lifting the pre-assembled towers into position by crane, attach the crane ropes to the horizontal members of the upper frames. Please note that the T-15 End Frame nor the Head Jacks should not be used for lifting.
- D. Base Jacks may only stand on a solid and sturdy foundation. The maximum allowable inclination is up to a maximum of 6%.
- E. During erection of the towers, make sure that the vertical Frames 100 and 133 are installed perpendicularly.
- F. Install bracing by Scaffold Tubes and Couplers in order to take over horizontal forces, if required, for statical reasons or other technical requirements.
- G. During erection and striking, it is important to consider simple auxiliary bracing or any other type of provisions in order to avoid tilting the T-15 support towers. In most cases, the installation of horizontal Scaffold Tubes which are connected to the adjacent legs of towers by means of Rigid/Swivel Couplers 48/48 may be adequate. Due to statical requirements, it is advisable to fix the Scaffold Tube of the bracing as close as possible to existing structural parts such as walls or columns for safe transmittal of forces. Also, a single support tower has to be stabilized to the ground by Scaffold Tubes and Couplers.
- H. It is recommended to carry out the final height adjustment (leveling) at the Head Jacks after placing the primary beams into position. Since the Head Jack can adapt up to a 6% inclination, greater inclinations have to be compensated by means of wooden wedges or leveling steel plates.
- I. All aspect of the approval and statical computation has to be followed.

## Dismantling:

For lowering the support system, it is advisable to release first the Head Jacks of the tower.

The dismantling of the frame support can be started after the H20 Timber Beams and/or steel beams/lattice girders have been removed from the top of the lowered support towers.

Dismantling of the tower in an upright position starts by removing the Head Jacks and by releasing and taking away one component after the other.

# Method of Statement

## Erection sequence

A. Place the T-15 End Frame on an even assembly ground within the working range of the crane.

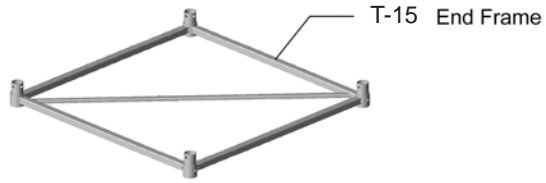

B. Insert 2 frames into the T-15 End Frame and lock them by means of the quick-fastening connectors

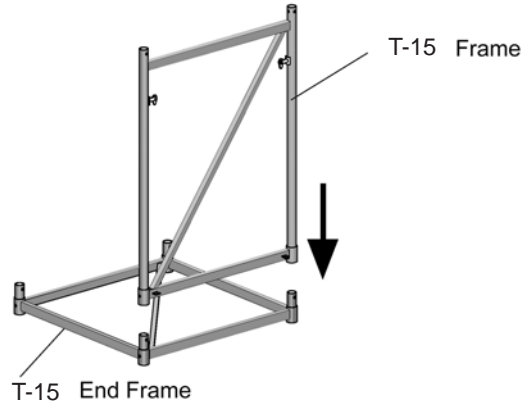

C. Fix the T-15 Diagonal with its lower end over the horizontal member of the vertical frame.

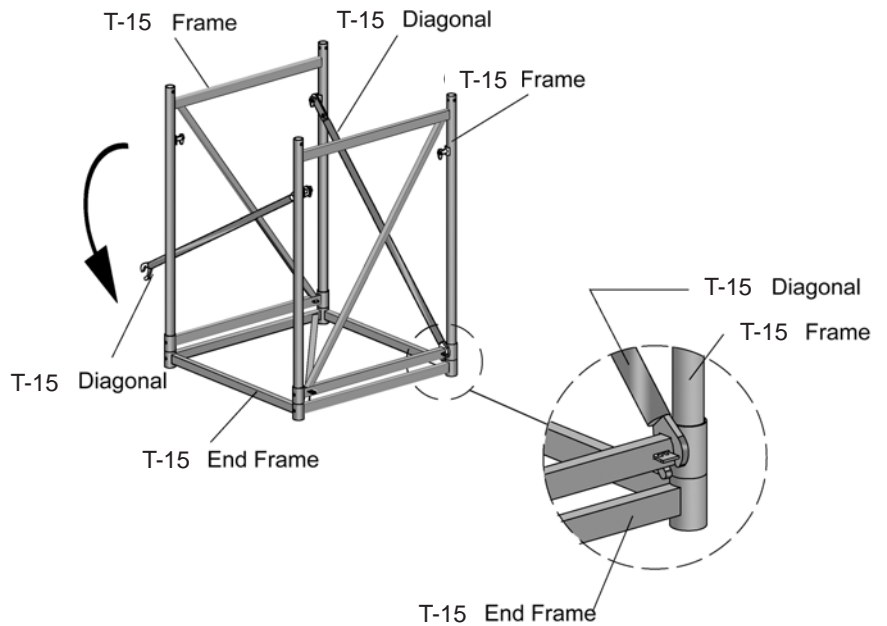

D. Turn the assembled unit on its side in order to complete assembly in a horizontal and safe manner.

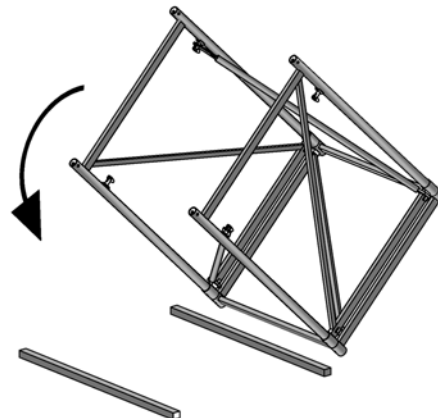

# Method of Statement

**E** Fix further horizontal frames and lock them with quick-fastening connectors.

**Note**

Prior to lifting into position the pre-assembled towers by crane, make sure the crane ropes are attached to the horizontal members of the upper frames.

**Attention**

Prior to lifting into position the pre-assembled towers by crane, make sure the crane ropes are attached to the horizontal members of the upper frame

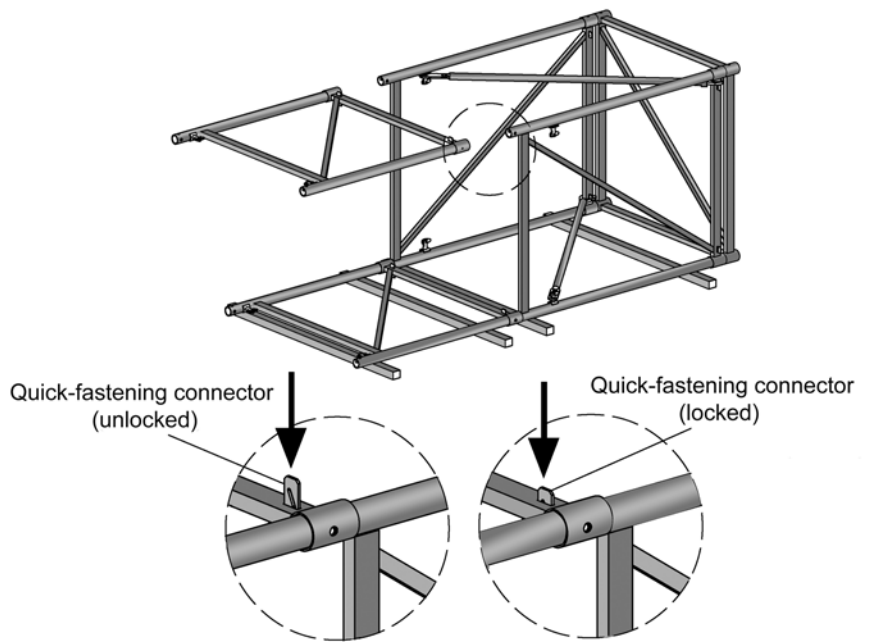

**F** Continue attaching additional vertical frames as described previously until the required combination height has been reached.

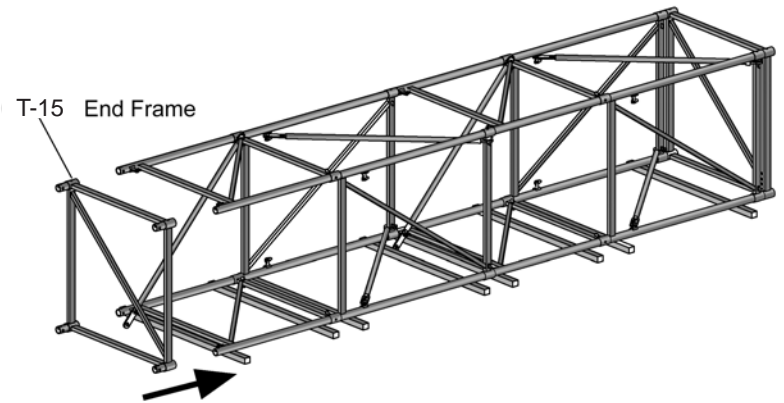

**G** Fix T-15 End Frame on the last 2 vertical frames.

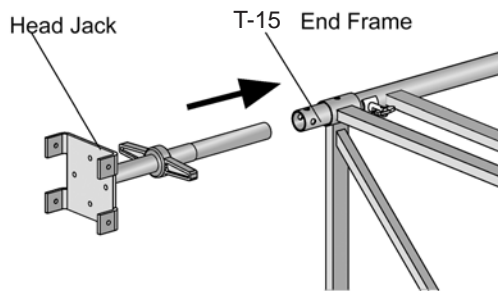

**H** Finally, insert Head Jacks into the T-15 End Frame.

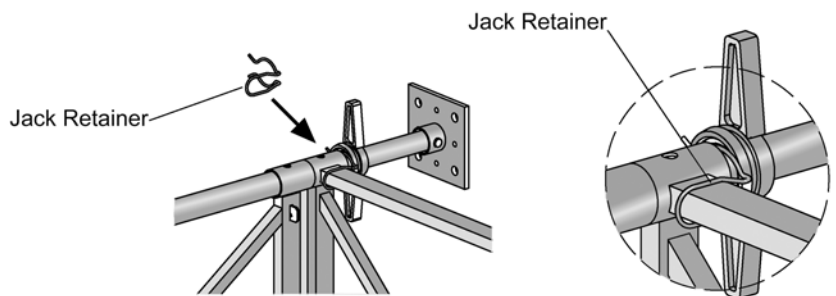

# Method of Statement

## Dismantling Sequence

It is advisable to carry out assembly and dismantling works from mobile scaffolding or from a working platform

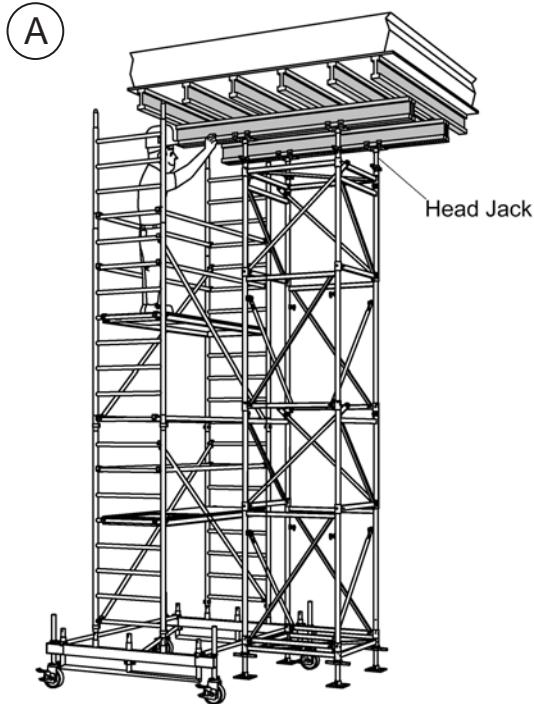

**Step A:** Dismantling starts by lowering the Head Jacks. The supported slab formwork has to be removed in accordance with the assembly and application guide of the formwork system applied.

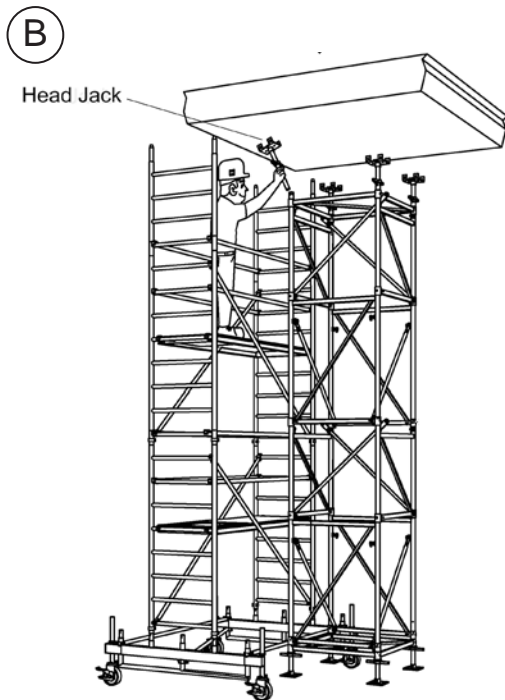

**Step B:** Dismantling of Head Jack

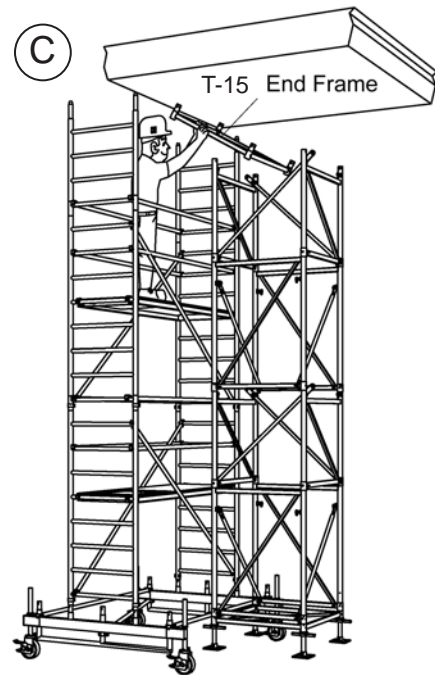

**Step C:** Dismantling of T-15 End Frame

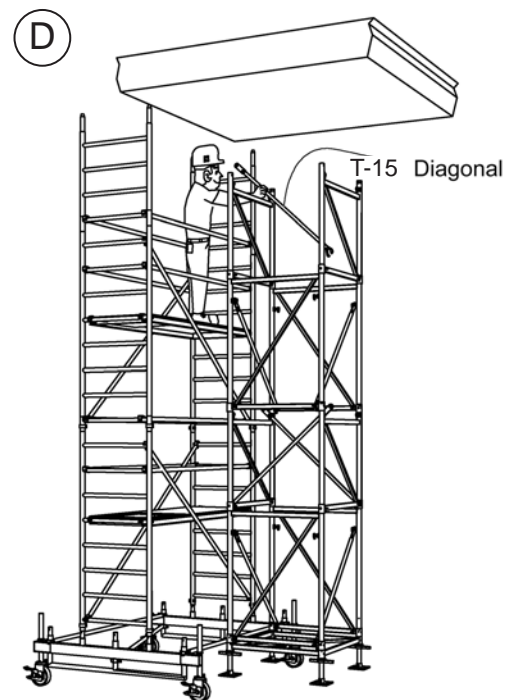

**Step D:** Dismantling of T-15 Diagonal

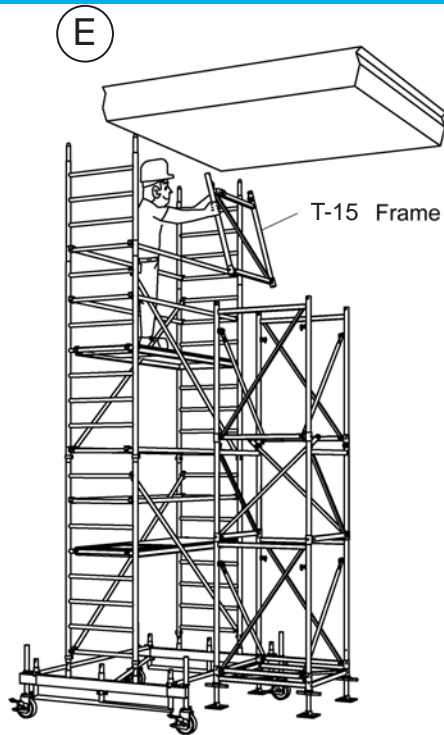

**Step E:** Dismantling of T-15 Frame

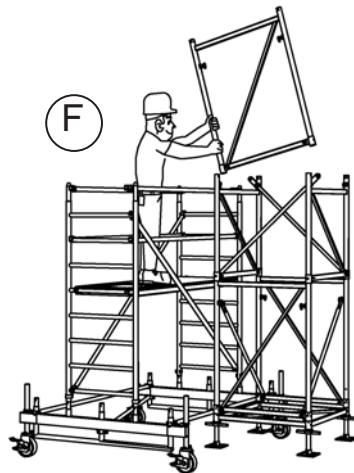

**Step F:** The working height of the mobile scaffold has to be adopted to the required height for all operations during erection and dismantling.

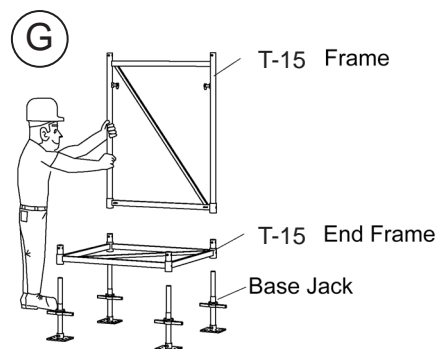

**Step G:** After removing the last two vertical frames at the bottom, the T-15 End Frame can be easily lifted and taken away from the 4 Base Jacks.

# Method of Statement

## Shifting Variations

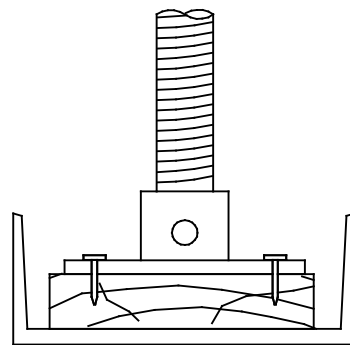
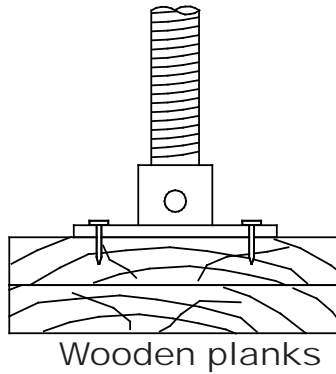
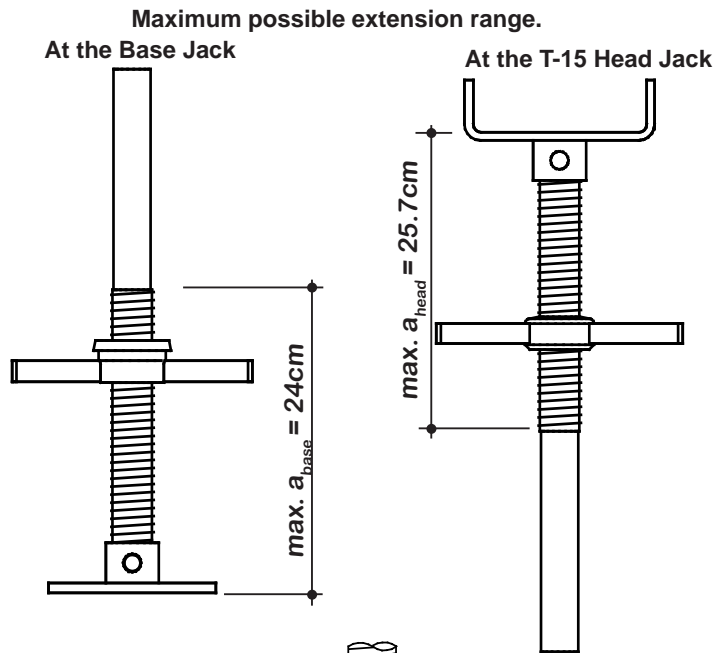

**Wooden plank in U-channel Steel profile**

The head plate adapts to slope of up to 6%

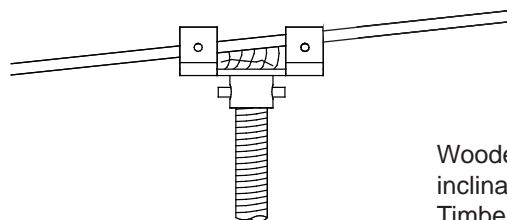

Wooden wedge for compensating inclination of primary beam (e.g. H20 Timber Beam, steel beam or lattice girder)

The longitudinal and cross directional distances of the T15 support towers have to be determined according to the vertical loads on the towers as shown in the corresponding statical computation.

**Assumption (V-load):**

Dead load of concrete, dead load of formwork, live load.

Horizontal loads from wind pressure and V/100 require bracing (Scaffold Tubes and Couplers) between towers for false work stability.

**Sample Application in Heavy Bridge**

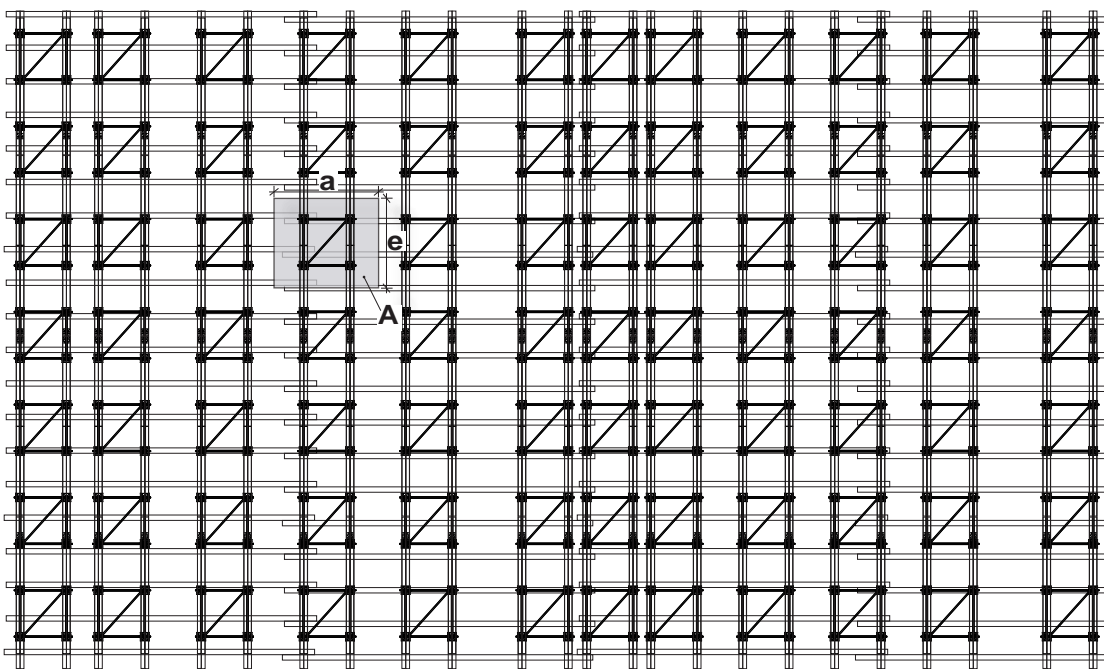
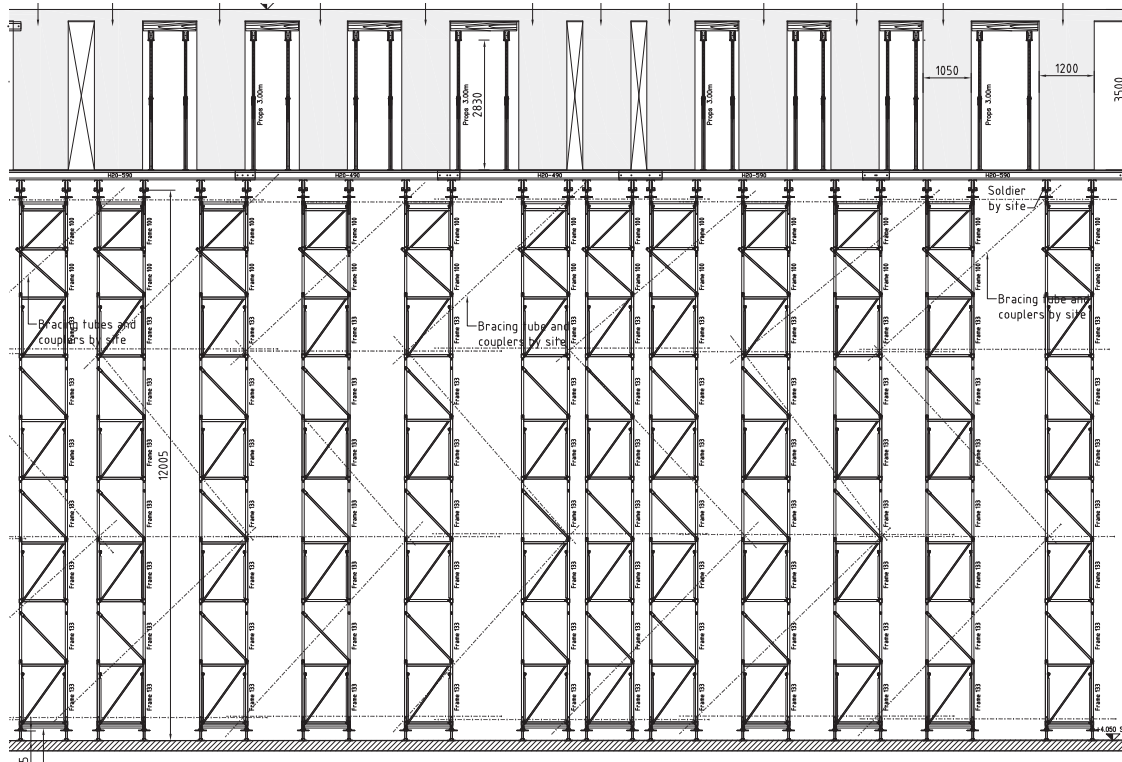

$$A = e \times a$$

# Application planning & Preparatory work

The quick and safe erection of T-15 110 frame supports can be significantly improved by:

1. Understanding the weight and level requirements of the structure to be supported.
2. Complete design analysis & calculation
3. Complete shop drawings, material list & erected steps
4. On time procurement of materials & component.
5. Ensure materials are in good condition & free from damages.
6. Ensure correct delivery is completed
7. Check that site personals are aware of how to use & erect
8. Check installation against drawing and make sure sites compiles with design.
9. Check any installation & statistical prior to concrete application

\* Wind pressure

$q = 0$	with the building (no wind)
$q = 0.5 \text{ kN / m}^2$	0-8 m over ground
$q = 0.8 \text{ kN / m}^2$	> 8-20 m over ground
$q = 1.1 \text{ kN / m}^2$	> 20-100 m over ground

shape coefficient for T-15 tower: 1.3

\* Wind load per rising "m" of T-15 110  $1.3 \times 0.4 \text{ m}^2/\text{m} \times q$

	$= 0.52 \text{ m}^2/\text{m} \times q$
0 to 8 m	$= 0.52 \times 0.5 = 0.26 \text{ kN/m}$
> 8 to 20 m	$= 0.52 \times 0.8 = 0.42 \text{ kN/m}$
> 20 to 100 m	$= 0.52 \times 1.1 = 0.57 \text{ kN/m}$

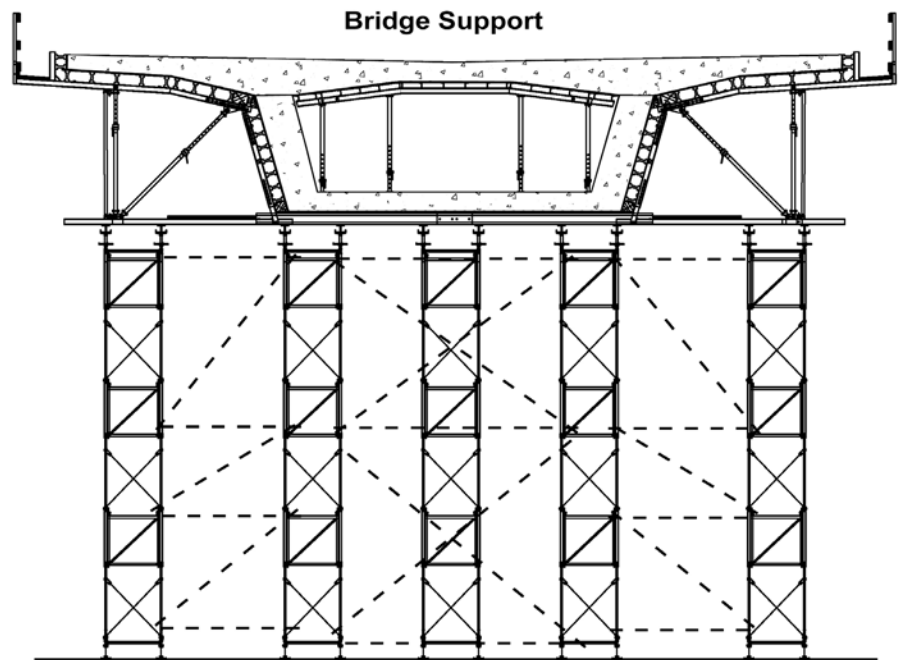

Static fundamentals for the design analysis of slab supporting systems

1. Weight density of freshly placed concrete:  $\gamma_c = 26.0 \text{ kN/m}^3$
2. Allow for dead load resulting from formwork, shoring structure, steel beams and / or timber formwork beams.
3. allow for live loads & horizontal loads from wind pressure according to place of application standards and codes

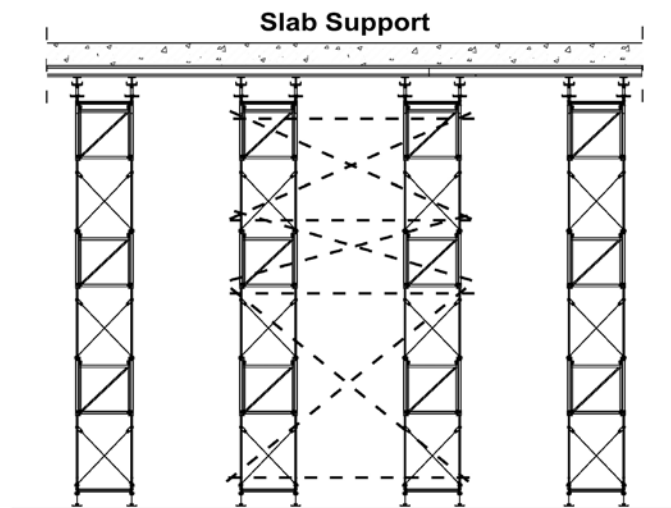

# T-15 Design Guide Lines

Loading Table (with H20 secondary beam and Double H20 primary beams)

"t" slab thickness [cm]													
"q" total loading [ kN/m <sup>2</sup> ]													
14	16	18	20	22	24	26	28	30	35	40	45	50	55
5.00	5.50	6.00	6.50	7.00	7.50	8.00	8.50	9.00	10.38	11.75	13.13	14.50	15.88

Secondary beam distance (m)	L = permissible distance of secondary beam [m]													
0.20	4.00	4.00	4.00	4.00	3.94	3.83	3.73	3.65	3.57	3.39	3.25	3.13	3.02	2.93
0.33	3.83	3.68	3.54	3.43	3.32	3.23	3.15	3.08	3.01	2.86	2.74	2.64	2.55	2.47
0.40	3.61	3.46	3.33	3.22	3.13	3.04	2.96	2.89	2.83	2.69	2.58	2.48	2.40	2.32
0.50	3.35	3.21	3.09	2.99	2.90	2.82	2.75	2.69	2.63	2.50	2.39	2.30	2.22	2.14
0.63	3.11	2.98	2.87	2.78	2.69	2.62	2.55	2.49	2.44	2.32	2.22	2.12	2.01	1.92
0.67	3.04	2.92	2.81	2.72	2.64	2.56	2.50	2.44	2.39	2.27	2.17	2.05	1.95	1.86
0.75	2.92	2.80	2.70	2.61	2.54	2.47	2.40	2.35	2.29	2.18	2.05	1.93	1.83	1.68

b loading widths [m] (b=L/2 + 0.5 m)	"A" Permissible distance of primary beams [m](double beams: 2 x H20 Timber Beams)																											
	Resulting loads per leg [kN]																											
	1.00	1.25	1.50	1.75	2.00	2.25	2.50	3.35	3.21	3.09	2.99	2.90	2.82	2.75	2.69	2.63	2.50	2.39	2.30	2.22	2.14							
	10.88	11.58	12.27	12.97	13.65	14.33	15.00	15.68	16.34	18.16	19.92	21.66	23.35	24.92	12.84	13.68	14.51	15.36	16.14	16.97	17.75	18.54	19.35	21.53	23.65	25.59	27.28	28.97
	2.92	2.80	2.70	2.61	2.54	2.47	2.40	2.35	2.29	2.18	2.05	1.93	1.83	1.68	14.70	15.68	16.65	17.60	18.59	19.52	20.40	21.36	22.21	24.74	26.88	28.84	30.78	31.91
	2.78	2.66	2.57	2.48	2.41	2.34	2.28	2.23	2.18	2.02	1.9	1.76	1.59	1.44	16.54	17.61	18.74	19.79	20.89	21.92	22.96	24.02	25.04	27.42	29.82	31.70	32.86	33.89
	2.66	2.55	2.46	2.37	2.3	2.24	2.17	2.1	2.04	1.89	1.73	1.54	1.39	1.26	18.30	19.53	20.76	21.91	23.10	24.30	25.36	26.35	27.36	29.98	32.08	33.34	34.66	35.88
	2.55	2.45	2.35	2.26	2.18	2.11	2.04	1.98	1.92	1.75	1.54	1.37	1.23	1.12	19.97	21.35	22.61	23.84	25.04	26.24	27.36	28.50	29.57	32.10	33.58	34.99	36.38	37.86
	2.44	2.33	2.23	2.15	2.07	2	1.94	1.88	1.82	1.58	1.38	1.23	1.11	1.01	21.50	22.89	24.23	25.59	26.86	28.13	29.40	30.60	31.73	33.46	34.96	36.59	38.24	39.89

"t" slab thickness [cm]													
"q" total loading [ kN/m <sup>2</sup> ]													
60	65	70	75	80	85	90	95	100	105	110	115	120	125
17.25	18.63	20	21.25	22.5	23.75	25	26.25	27.5	28.75	30	31.25	32.5	33.75

Secondary beam distance (m)	L = permissible distance of secondary beam [m]													
0.20	2.84	2.77	2.70	2.64	2.59	2.54	2.49	2.45	2.40	2.37	2.33	2.30	2.26	2.23
0.33	2.40	2.34	2.28	2.23	2.18	2.12	2.06	2.00	1.96	1.92	1.88	1.85	1.81	1.75
0.40	2.26	2.20	2.13	2.06	1.99	1.93	1.88	1.83	1.76	1.69	1.62	1.56	1.51	1.46
0.50	2.05	1.97	1.90	1.84	1.75	1.64	1.55	1.47	1.41	1.35	1.30	1.25	1.21	1.17
0.63	1.84	1.71	1.59	1.49	1.40	1.31	1.24	1.18	1.13	1.08	1.04	1.00	—	—
0.67	1.74	1.61	1.49	1.39	1.31	1.23	1.16	1.10	1.06	1.01	—	—	—	—
0.75	1.55	1.43	1.33	1.24	1.16	1.10	1.04	—	—	—	—	—	—	—

b loading widths [m] (b=L/2 + 0.5 m)	"A" Permissible distance of primary beams [m](double beams: 2 x H20 Timber Beams)																									
	resulting loads per leg [kN]																									
	1.00	1.25	1.50	1.75	2.05	1.97	1.90	1.84	1.75	1.64	1.55	1.47	1.41	1.35	1.30	1.25	1.21	1.17								
	26.31	27.66	29.00	30.18	30.94	31.35	31.88	32.42	33.14	33.78	34.50	35.16	35.91	36.62	1.84	1.71	1.59	1.49	1.4	1.31	1.24	1.18	1.13	1.08	1.04	1.00
	30.62	31.55	32.38	33.07	33.75	34.29	35.00	35.77	36.61	37.38	38.25	39.06			1.55	1.43	1.33	1.24	1.16	1.10	1.04					
	32.99	33.94	34.95	35.70	36.45	37.41	38.25								1.33	1.22	1.14	1.06								
	35.17	36.18	37.45	38.30																						

## Secondary beam distance (m)

Deflections of beams are limited to L/500.  
Please note that the above loading table should be considered as a general indication for technical elaborations but does not replace an individual structural proof for the final stability of the whole structure.

## Load assumptions

- w<sub>f</sub> dead load for formwork = 0.25 kN/m<sup>2</sup>
- w<sub>c</sub> load of concrete = t [m] x 25.0 kN/m<sup>3</sup>
- weight density of concrete = 25 kN/m<sup>3</sup>
- p live load p = 0.75+(0.75 x 0.1 x W<sub>c</sub> > 1.75) kN/m<sup>2</sup>
- Total load q = w<sub>f</sub>+w<sub>c</sub>+p [ kN/m<sup>2</sup> ]

# Preparation of Material List

Art No.:	600101	600102	600104	600105	600103	600106	Weight of tower kg
Weight/item [kg]	8.2	8.0	19.1	16.1	15.8	2.8	
Height of tower M	Head Jack	Base Jack	T-15 Frame 133	T-15 Frame 100	T-15 20 End Frame	T-15 Diagonal	
1.42 - 1.75	4	4	-	2	2	2	134.2
1.75 - 2.08	4	4	2	-	2	2	140.2
1.85 - 2.17	4	4	2	-	2	2	156.0
1.93 - 2.26	4	4	2	-	2	2	171.8
2.42 - 2.75	4	4	-	4	2	4	172.0
2.75 - 3.08	4	4	2	2	2	4	178.0
3.09 - 3.42	4	4	4	-	2	4	184.0
3.42 - 3.75	4	4	-	6	2	6	209.8
3.75 - 4.08	4	4	2	4	2	6	215.8
4.09 - 4.72	4	4	4	2	2	6	221.8
4.42 - 4.75	4	4	6	-	2	6	227.8
4.75 - 5.08	4	4	2	6	2	8	253.6
5.09 - 5.42	4	4	4	4	2	8	259.6
5.42 - 5.75	4	4	6	2	2	8	265.6
5.76 - 6.09	4	4	8	-	2	8	271.6
6.09 - 6.42	4	4	4	6	2	10	297.4
6.42 - 6.75	4	4	6	4	2	10	303.4
6.76 - 7.09	4	4	8	2	2	10	309.4
7.09 - 7.42	4	4	10	-	2	10	315.4
7.42 - 7.75	4	4	6	6	2	12	341.2
7.76 - 8.09	4	4	8	4	2	12	347.2
8.09 - 8.42	4	4	10	2	2	12	353.2
8.43 - 8.76	4	4	12	-	2	12	359.2
8.76 - 9.09	4	4	8	6	2	14	385.0
9.09 - 9.42	4	4	10	4	2	14	391.0
9.43 - 9.76	4	4	12	2	2	14	397.0
9.76 - 10.09	4	4	14	-	2	14	403.0
10.09 - 10.42	4	4	10	6	2	16	428.8
10.43 - 10.76	4	4	12	4	2	16	434.8
10.76 - 11.09	4	4	14	2	2	16	440.8
11.10 - 11.43	4	4	16	-	2	16	446.8
11.43 - 11.76	4	4	12	6	2	18	472.6
11.76 - 12.09	4	4	14	4	2	18	478.6
12.10 - 12.43	4	4	16	2	2	18	484.6
12.43 - 12.76	4	4	18	-	2	18	490.6
12.76 - 13.09	4	4	14	6	2	20	516.4
13.10 - 13.43	4	4	16	4	2	20	522.4
13.43 - 13.76	4	4	18	2	2	20	528.4
13.77 - 14.10	4	4	20	-	2	20	534.4
14.10 - 14.43	4	4	16	6	2	22	560.2
14.43 - 14.76	4	4	18	4	2	22	566.2
14.77 - 15.10	4	4	20	2	2	22	572.2
15.10 - 15.43	4	4	22	-	2	22	578.2
15.43 - 15.76	4	4	18	6	2	24	604.0
15.77 - 16.10	4	4	20	4	2	24	610.0
16.10 - 16.43	4	4	22	2	2	24	616.0
16.44 - 16.77	4	4	24	-	2	24	622.0
16.77 - 17.10	4	4	20	6	2	26	647.8
17.10 - 17.43	4	4	22	4	2	26	653.8
17.44 - 17.77	4	4	24	2	2	26	659.8
17.77 - 18.10	4	4	26	-	2	26	665.8
18.10 - 18.43	4	4	22	6	2	28	691.6
18.44 - 18.77	4	4	24	4	2	28	697.6
18.77 - 19.10	4	4	26	2	2	28	703.6
19.10 - 19.44	4	4	28	-	2	28	709.6
19.44 - 19.77	4	4	24	6	2	30	735.4
19.77 - 20.10	4	4	26	4	2	30	714.4

For the calculation of the required assembly and dismantling guiding figures should be taken into consideration:

for each procedure, (assembling and dismantling) approximately 4 hours per ton on an average should be calculated based on 0.17 hours per rising meter.

the required time for tubes and couplers should be calculated as 25 to 30 hours based on the weight of the T-15 support tower.

## T-15 Support Tower Combination Sample

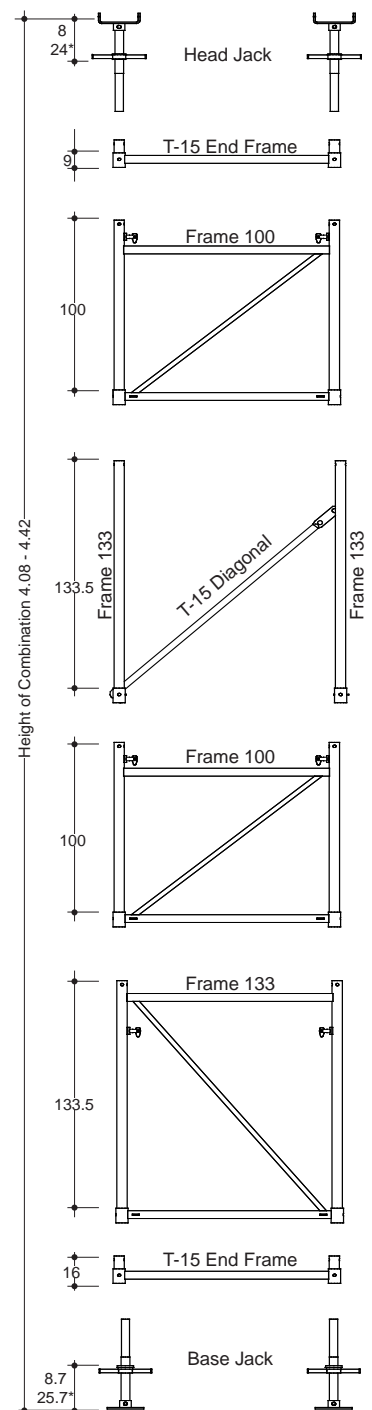

# H20 Wall & Column Formwork

Quick & Easy System



## Product Features

The basis of the H20 Wall and Column Formwork system is the H20 Timber Beam. The H20 Timber Beam is made of the highest quality with competitive advantages.

The H20 Timber Beam is sturdy, easy to handle and only weighs 4.60 kg/m. It provides a high load-bearing capacity even for great distances of Walers. This advantage results to less anchor points. The project oriented design and arrangement of the H20 Timber Beam elements allow choices of various types of plywood sheet. Furthermore, the system allows an optimum and flexible arrangement of tie positions.

The H20 wall formwork elements are assembled quickly and cosily by connecting the H20 Timber Beams to the Walers by means of H20 Timber Beam Clamp. Dismantling of elements is done as easily as the erection of

the system. The advantage is that the wall formwork system provides a high adaptation and easy re-assembling when ground plans of the structure change frequently.

The H20 wall and column formwork system is one of the most economical alternative to steel frame formwork panel system when it comes to complicated designs and numerous non-typical applications with the same wall heights.

The H20 wall and column formwork system is used for all types of walls and columns and has high rigidity and stability at a relatively low weight.

The H20 Wall and Column Formwork is designed and manufactured in accordance with BS EN 12812 : 2008, code of practice for Falsework



# Overview

## UF system

1. Steel Waler
2. H20 Timber Beam
3. Waler Head Anchor
4. PP Strut
5. Outside Corner U
6. Adjustable Waler Coupler
7. T-Waler Coupler
8. Corner Waler Coupler
9. Working Bracket
10. Lifting Bracket

## HP system

1. Steel Waler
2. H20 Timber Beam
3. Tension Strap
4. Wall Strut & Sprag Brace
5. Outer Corner Bearing
6. Steel Waler Connector 100/165
7. Corner Connector L24
8. Corner Connector 60x60
9. Walkway Bracket
10. Lifting Bracket

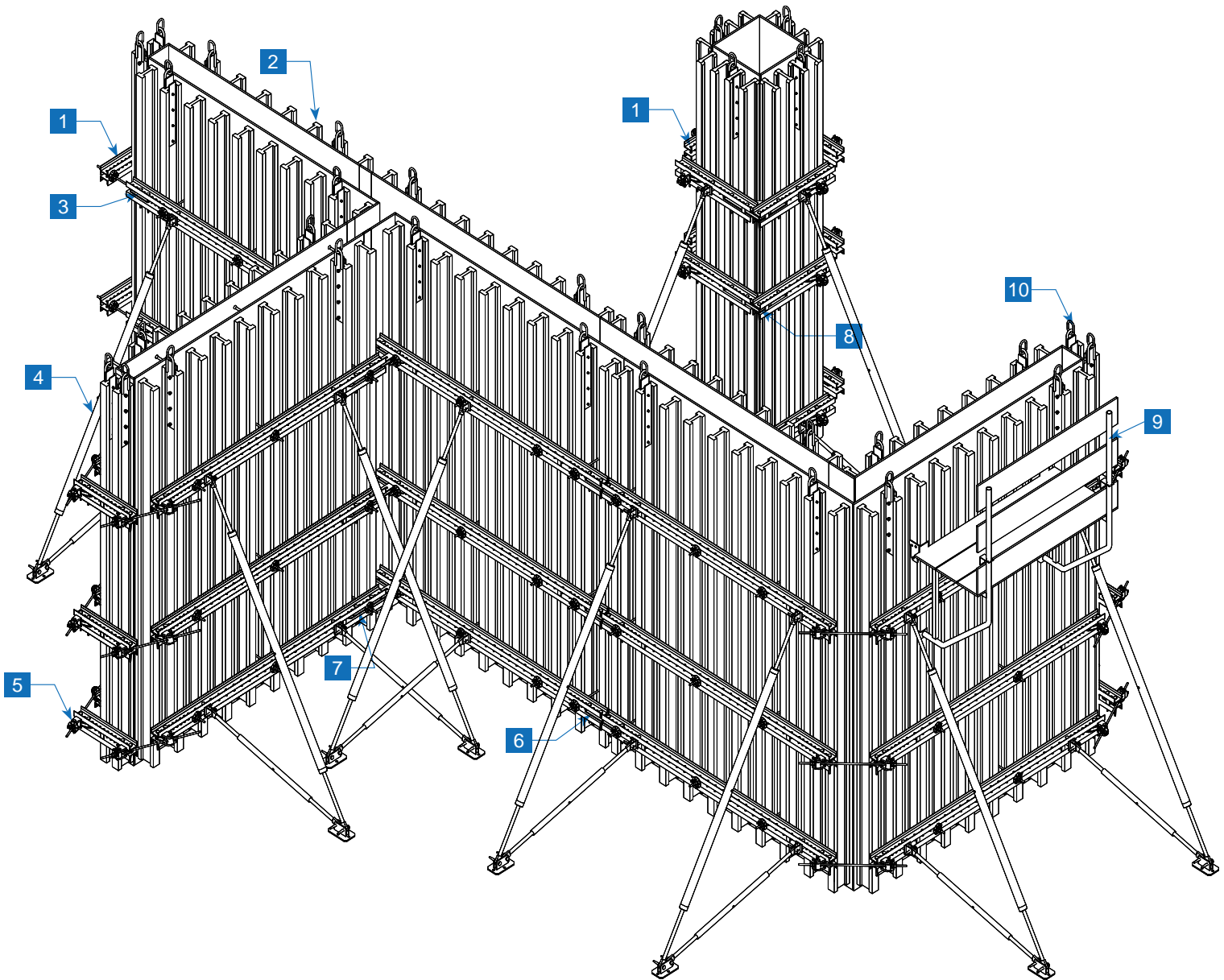

## System Components

Description	Art. No	Weight
-------------	---------	--------

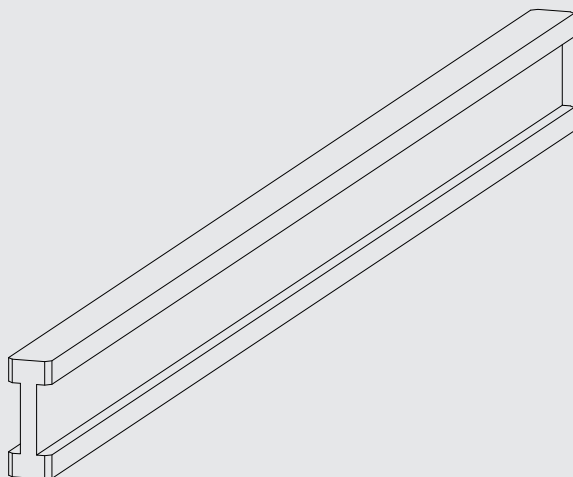

### H20 Timber Beam

With End cap protection

H20 - Timber Beam 2.00	0000018	9.20
H20 - Timber Beam 2.45	0000002	11.27
H20 - Timber Beam 2.65	0000003	12.19
H20 - Timber Beam 3.00	0000016	13.80
H20 - Timber Beam 3.30	0000005	15.18
H20 - Timber Beam 3.60	0000006	16.56
H20 - Timber Beam 3.90	0000007	17.94
H20 - Timber Beam 4.50	0000008	20.70
H20 - Timber Beam 4.90	0000009	22.54
H20 - Timber Beam 5.50	0000014	25.30
H20 - Timber Beam 5.90	0000010	27.14

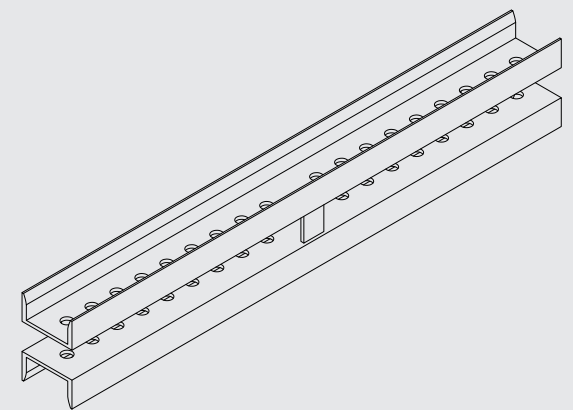

### Steel Waler

Steel Waler 10-0.50m	600256	10.40
Steel Waler 10-0.75m	600257	15.40
Steel Waler 10-1.00m	600258	20.20
Steel Waler 10-1.25m	600259	25.00
Steel Waler 10-1.50m	600260	30.30
Steel Waler 10-2.00m	600261	40.20
Steel Waler 10-2.50m	600262	51.00
Steel Waler 10-3.00m	600263	60.40
Steel Waler 10-3.75m	600264	71.50
Steel Waler 10-5.00m	600265	102.00
Steel Waler 10-6.00m	600266	122.20

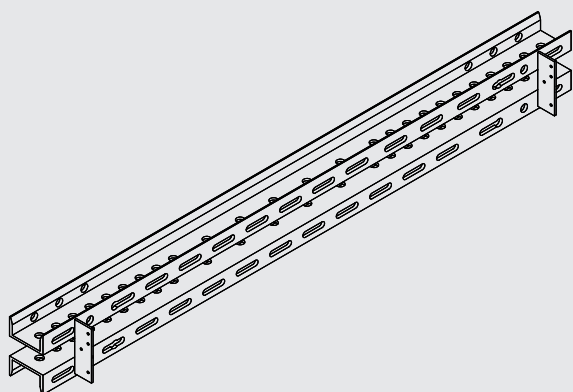

Multi Purpose Steel Waler 10-0.50m	600300	10.20
Multi Purpose Steel Waler 10-0.75m	600301	14.90
Multi Purpose Steel Waler 10-1.00m	600302	19.60
Multi Purpose Steel Waler 10-1.25m	600303	24.70
Multi Purpose Steel Waler 10-1.50m	600304	29.70
Multi Purpose Steel Waler 10-2.00m	600305	38.90
Multi Purpose Steel Waler 10-2.50m	600306	48.70
Multi Purpose Steel Waler 10-3.00m	600307	60.20
Multi Purpose Steel Waler 10-3.75m	600308	71.20
Multi Purpose Steel Waler 10-5.00m	600309	101.60
Multi Purpose Steel Waler 10-6.00m	600310	122.00

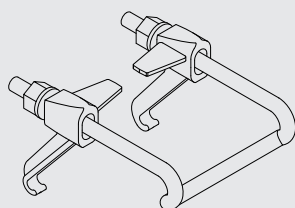





### Flange Clamp

601105	1.00
--------	------

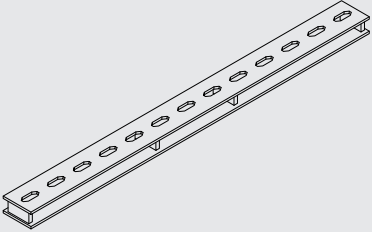
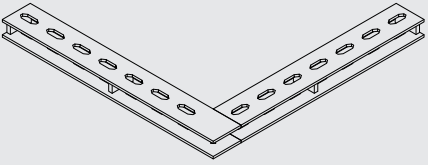
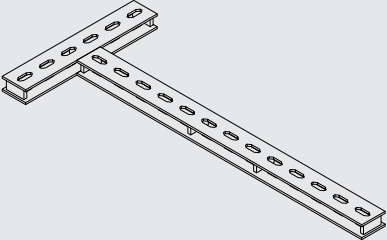
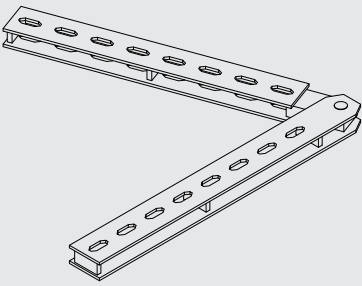
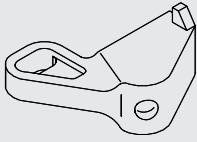
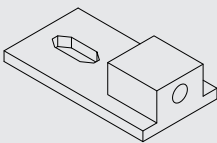
Used for height extension of the wall formwork elements

System Components

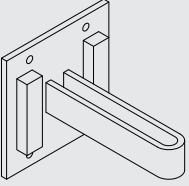
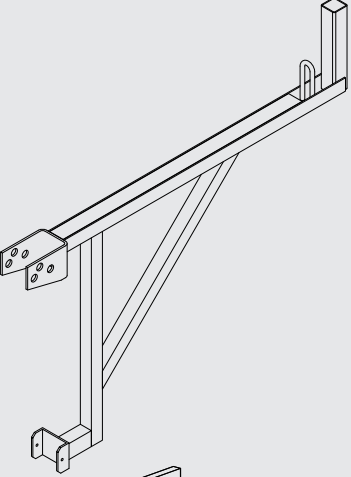
	Description	Art. No	Weight
	Steel Waler Connector		
	Steel Waler Connector - 100	600208	7.60
	Steel Waler Connector - 165	600209	13.15
	For connecting two waler with joining wedge		
	Corner Connector 60x60	600210	9.16
	For connecting H2O Panel in 90' inner corner		
	Corner Connector L24	600211	11.50
	Alternatively used for forming an inner corner with length adjustments in combination with Joining Wedges.		
	Hinged Connector		
	Hinged Connector 60x60	600213	13.00
	Double Hinged Connector	600214	13.50
	Outer Corner Bearing	600215	1.20
	To be attached to the waler by means of connecting pin at the end if the wall elements for bracing and stiffening the outer corner.		
	Tension Strap	600216	1.30
	Used to tie walers in perpendicular position at stopends		

	Description	Art. No	Weight
	<p><b>Joining Wedge</b> Used for height extension of the wall formwork elements</p>	600217	0.80
	<p><b>Beam Fixing Device</b> Used in combination with infill panels for elements length adjustment and fixed by nails to the H20 Timber Beams. The Waler connectors are attached to the Beam Fixing Device by a Wedge</p>	600218	1.10
	<p><b>TB Walkway Bracket</b> Equipped with upper U-profile where wooden beams on top can be fasten by nails. Furthermore, the bracket is built in with handrail post.</p>	600219	16.50
	<p><b>Wedge</b> Used for securing the Beam Fixing Device to the H20 Timber Beams and attaching Aligning Struts and Wall Braces</p>	600220	0.40
	<p><b>Railing Post</b> Used in combination with TB walkway Bracket</p>	600221	3.20

System Components

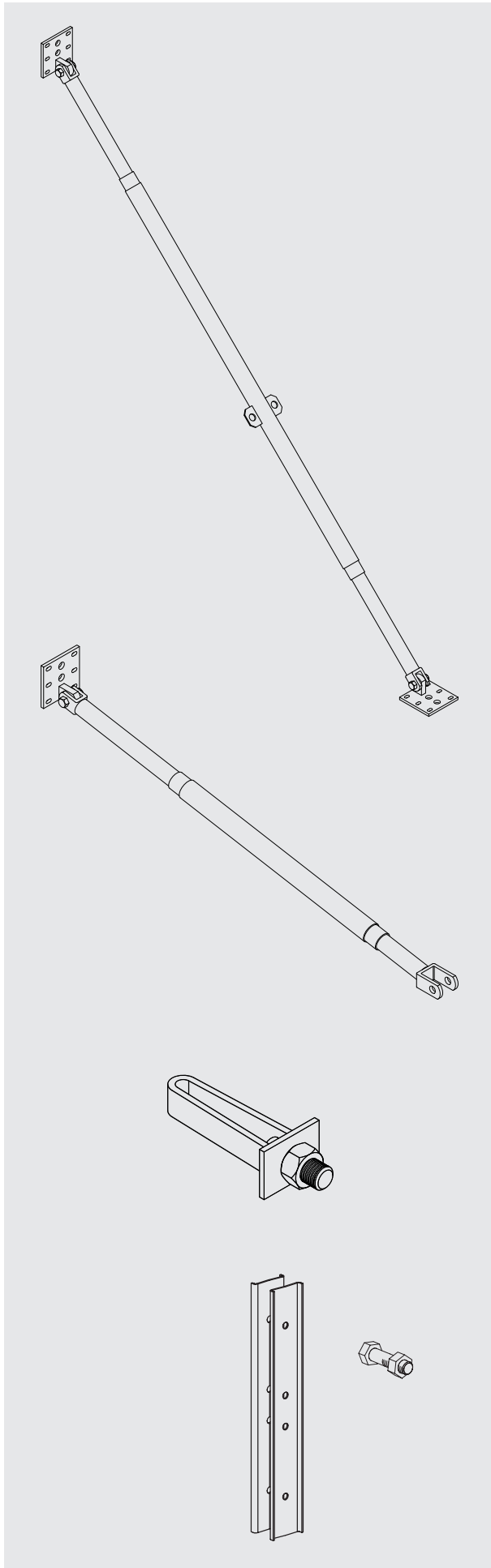

Description	Art. No	Weight
<b>Wall Strut</b>		
Wall Strut 170-240	600223	19.70
Wall Strut 220-290	600224	21.20
Wall Strut 270-340	600225	22.10
Wall Strut 320-390	600226	24.30
Wall Strut 420-490	600227	27.15
Wall Strut 530-590	600228	40.25
For aligning the Formwork Element. to be attached to the waler		
<b>Sprag Brace</b>		
Sprag Brace 120-190	600229	16.20
Sprag Brace 170-240	600230	18.10
<b>Strut Wedge Strap</b>		
	600231	1.00
For fixing the hinge plates of the Wall Strut and Sprag Braces to the Walers by means of Wedge.		
<b>H2O Extension Piece</b>		
	600232	9.30
Used for height extension of the wall formwork elements		

System Components

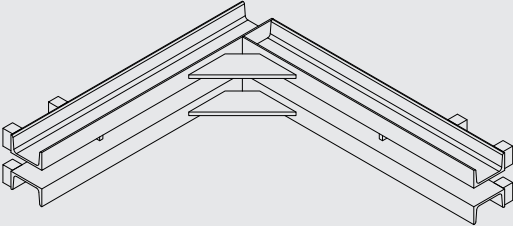
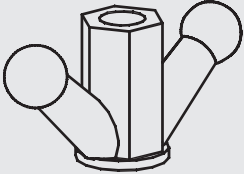
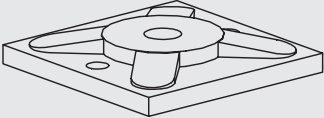
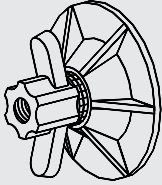
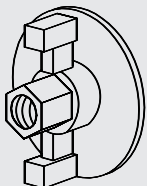
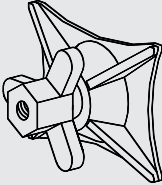
	Description	Art. No	Weight
	<p>Column Waler</p> <p>Column Walers 72X72</p> <p>Column Walers 89X89</p> <p>Column Walers 106X106</p> <p>Column Walers 123X123</p>	<p>600233</p> <p>600234</p> <p>600235</p> <p>600236</p>	<p>35.20</p> <p>44.10</p> <p>51.60</p> <p>60.20</p>
	<p>Wing Nut</p>	<p>600238</p>	<p>0.40</p>
	<p>Galvanized Plate 12x12</p>	<p>600239</p>	<p>1.10</p>
	<p>Vito Tie Nut</p>	<p>600247</p>	<p>1.30</p>
	<p>Tension Nut</p>	<p>600246</p>	<p>0.80</p>
	<p>Tie Nut 230</p>	<p>600248</p>	<p>2.50</p>

## System Components

Description	Art. No	Weight
-------------	---------	--------

### H2O Timber Beam

H20 - Timber Beam 2.00	0000018	9.20
H20 - Timber Beam 2.45	0000002	11.27
H20 - Timber Beam 2.65	0000003	12.19
H20 - Timber Beam 3.00	0000016	13.80
H20 - Timber Beam 3.30	0000005	15.18
H20 - Timber Beam 3.60	0000006	16.56
H20 - Timber Beam 3.90	0000007	17.94
H20 - Timber Beam 4.50	0000008	20.70
H20 - Timber Beam 4.90	0000009	22.54
H20 - Timber Beam 5.50	0000014	25.30
H20 - Timber Beam 5.90	0000010	27.14

### Steel Waler

Steel Waler 10-0.50m	600256	10.40
Steel Waler 10-0.75m	600257	15.40
Steel Waler 10-1.00m	600258	20.20
Steel Waler 10-1.25m	600259	25.00
Steel Waler 10-1.50m	600260	30.30
Steel Waler 10-2.00m	600261	40.20
Steel Waler 10-2.50m	600262	51.00
Steel Waler 10-3.00m	600263	60.40
Steel Waler 10-3.75m	600264	71.50
Steel Waler 10-5.00m	600265	102.00
Steel Waler 10-6.00m	600266	122.20

Multi Purpose Steel Waler 10-0.50m	600300	10.20
Multi Purpose Steel Waler 10-0.75m	600301	14.90
Multi Purpose Steel Waler 10-1.00m	600302	19.60
Multi Purpose Steel Waler 10-1.25m	600303	24.70
Multi Purpose Steel Waler 10-1.50m	600304	29.70
Multi Purpose Steel Waler 10-2.00m	600305	38.90
Multi Purpose Steel Waler 10-2.50m	600306	48.70
Multi Purpose Steel Waler 10-3.00m	600307	60.20
Multi Purpose Steel Waler 10-3.75m	600308	71.20
Multi Purpose Steel Waler 10-5.00m	600309	101.60
Multi Purpose Steel Waler 10-6.00m	600310	122.00

### Flange Clamp

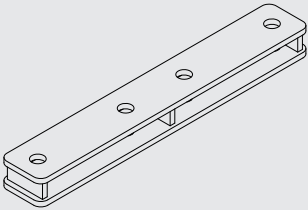
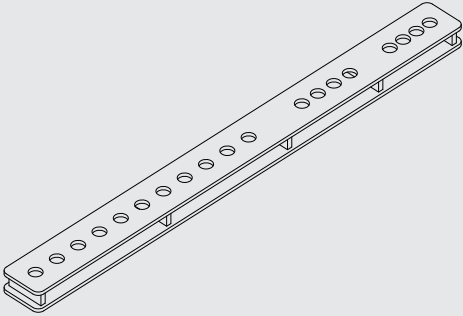
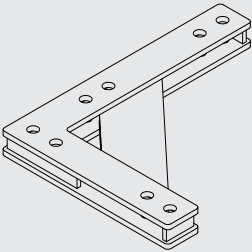
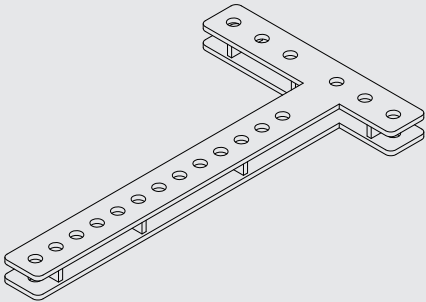
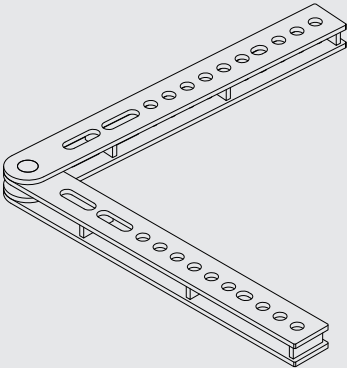

601105	1.00
--------	------

Used for height extension of the wall formwork elements

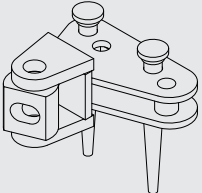
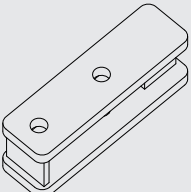
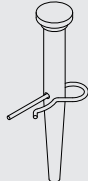
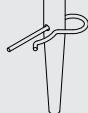
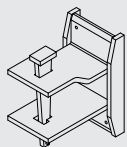
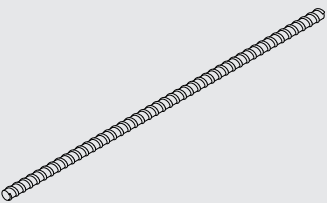
	Description	Art. No	Weight
	<p><b>Waler Coupler</b></p> <p>Used to connect two panels and also It joins two walers lengthwise to form longer one.</p>	600273	4.20
	<p><b>Adjustable Waler Coupler</b></p> <p>This coupler joins two steel waler to forma long one, and to connect panels with a closures between them.</p>	600267	5.10
	<p><b>Corner Waler Coupler</b></p> <p>Used for forming L shape panels to form column formworks.</p>	600268	11.40
	<p><b>T - Waler Coupler</b></p> <p>Used for forming an inner corner with length adjustments in combination with connecting pin to form column formworks.</p>	600269	8.11
	<p><b>Articulated Waler Coupler</b></p> <p>Used for the arrangement of polygonal element connections.</p>	600270	7.35

	Description	Art. No	Weight
	<p><b>Outside Corner U</b></p> <p>To be attached to the walers by means of connecting pin at the end of the wall element for bracing and stiffening the outer corner.</p>	600271	3.60
	<p><b>Waler Head Anchor U</b></p> <p>Used in combination with a connecting pin for stopends. it is used together with tie rod 15mm dia. and Flange nut</p>	600272	1.75
	<p><b>Connecting Pin U 20x190</b></p>	600274	0.50
	<p><b>Spring Cotter 5mm</b></p>	600275	0.05
	<p><b>Beam Coupler Plate</b></p> <p>Connects to adjustable waler coupler and is fixed to H2O beams, providing support for adjustable infill panels.</p>	600276	2.10
	<p><b>Tie Rod</b></p> <p>Tie Rod 15 mm Dia./D&amp;W 50</p> <p>Tie Rod 15 mm Dia./D&amp;W 75</p> <p>Tie Rod 15 mm Dia./D&amp;W 100</p> <p>Tie Rod 15 mm Dia./D&amp;W 130</p> <p>Tie Rod 15 mm Dia./D&amp;W 175</p>	<p>600286</p> <p>600240</p> <p>600241</p> <p>600242</p> <p>600242</p>	<p>1.20</p> <p>1.50</p> <p>1.95</p> <p>2.45</p> <p>2.45</p>

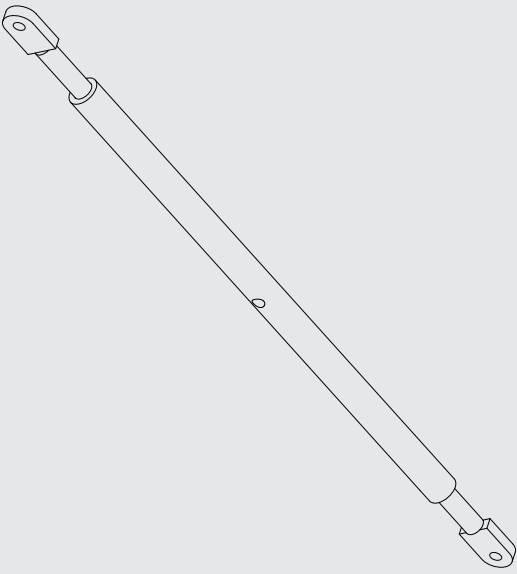
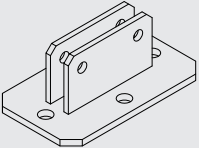
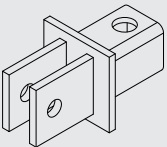
System Components

	Description	Art. No	Weight
	<p>Push Pull Strut</p> <p>Push Pull Strut 1.10-1.70 m</p> <p>Push Pull Strut 2.40-3.50 m</p> <p>Push Pull Strut 3.60-4.80 m</p> <p>Push Pull Strut 5.00-6.00 m</p>	<p>600278</p> <p>600279</p> <p>600280</p> <p>600281</p>	<p>7.80</p> <p>24.50</p> <p>43.50</p> <p>51.50</p>
	<p>Push Pull Strut Base</p>	<p>600282</p>	<p>3.70</p>
	<p>Push Pull Strut Head</p>	<p>600283</p>	<p>2.80</p>
	<p>Lifting Bracket</p>	<p>600285</p>	<p>6.20</p>

System Components

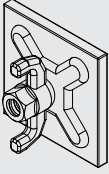
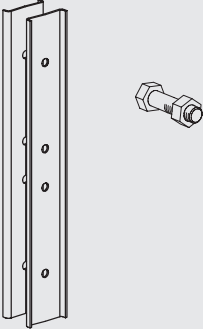
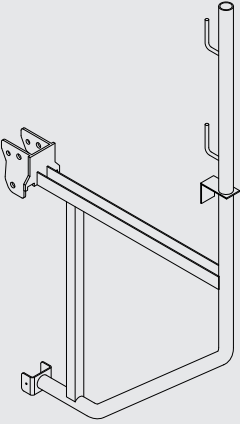
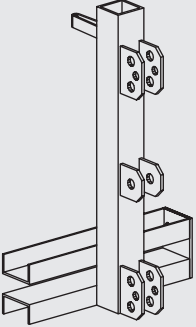
	Description	Art. No	Weight
	<p>Plate Washer Nut</p>	<p>600284</p>	<p>1.50</p>
	<p>H2O Extension Piece</p> <p>Used for height extension of the wall formwork elements</p>	<p>600232</p>	<p>9.30</p>
	<p>Working Bracket</p> <p>Equipped with upper U-profile where wooden beams on top can be fasten by nails. Furthermore, the bracket is built in with handrail post.</p>	<p>600277</p>	<p>17.00</p>
	<p>Bk Strut Connector</p>	<p>600910</p>	<p>9.10</p>



Description

Art. No

Weight

## BKS Align Strut

Hingless End Section	600249	29.50
Intermdiate Section 370	600250	62.50
Intermdiate Section 240	600251	44.20
Hinged End Section	600252	36.50
Bolt M16X60 With Nut 4 Pcs/Joint	600253	0.15
Fit Bolt M20X80 with Nut 1 pc	600254	0.45

# Pre-Assembly of Elements

## A. Basic Assembly

For basic assembly of the H20 elements, an assembly floor big enough for the largest wall formwork element has to be prepared. To ensure the exact position of the H20 Walers and Timber Beams, stop bars have to be fixed on the ground. The position of the stop bars should correspond to the spacing of the Walers

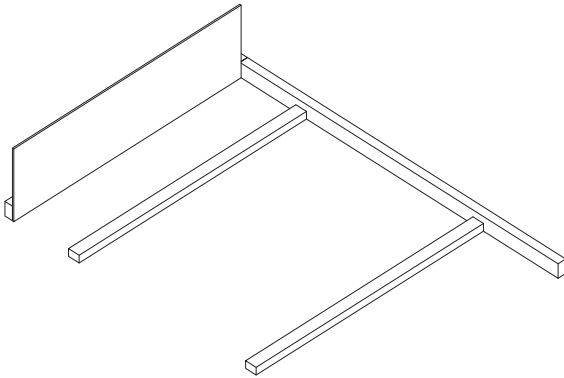

## B. Waler Positioning

The Walers have to be placed on the assembly ground with the traverse on top facing upward.

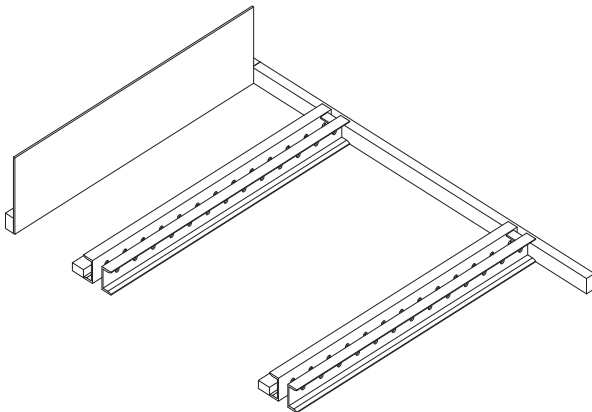

## C. H20 Timber Beam Positioning

The spacing and positioning of the H20 Timber Beams are arranged based on the statical requirements. The H20 Timber Beam is fixed to the Waler using H20 Flange Clamps.

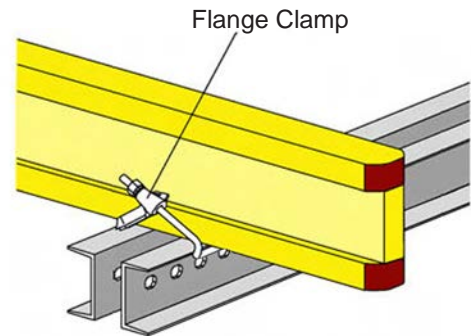
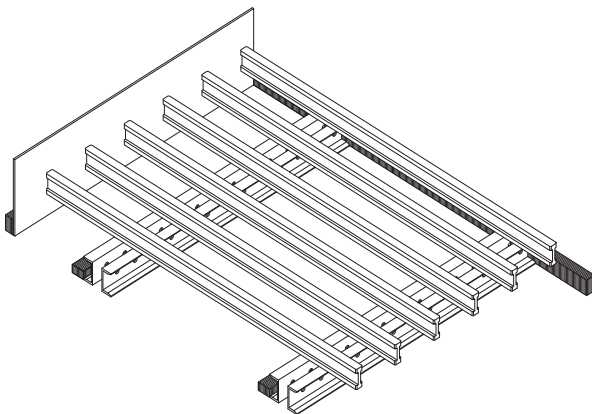

## D. Fixing the Plywood Sheet

The plywood is fixed to the shuttering grid by means of nails, screw nails, or Spax screws.

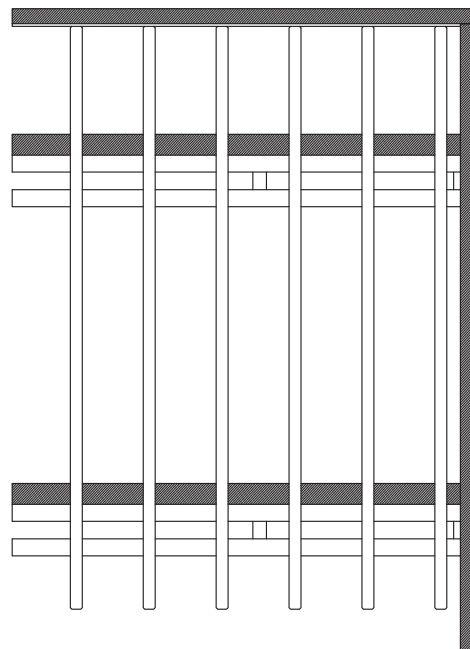

**Note:-**

H20 beams must be pre-drilled prior to assembly to accommodate fixing of working and lifting bracket. Check your formwork shop drawings regarding correct placement of pre-drilled beams

# Method of Statement

## T-Shaped Wall Arrangement

The arrangement of a T-shape wall can be done with standard wall formwork elements and an additional infill panel which is fixed by means of Adjustable Water Coupler.

The inner corners are arranged with standard elements.

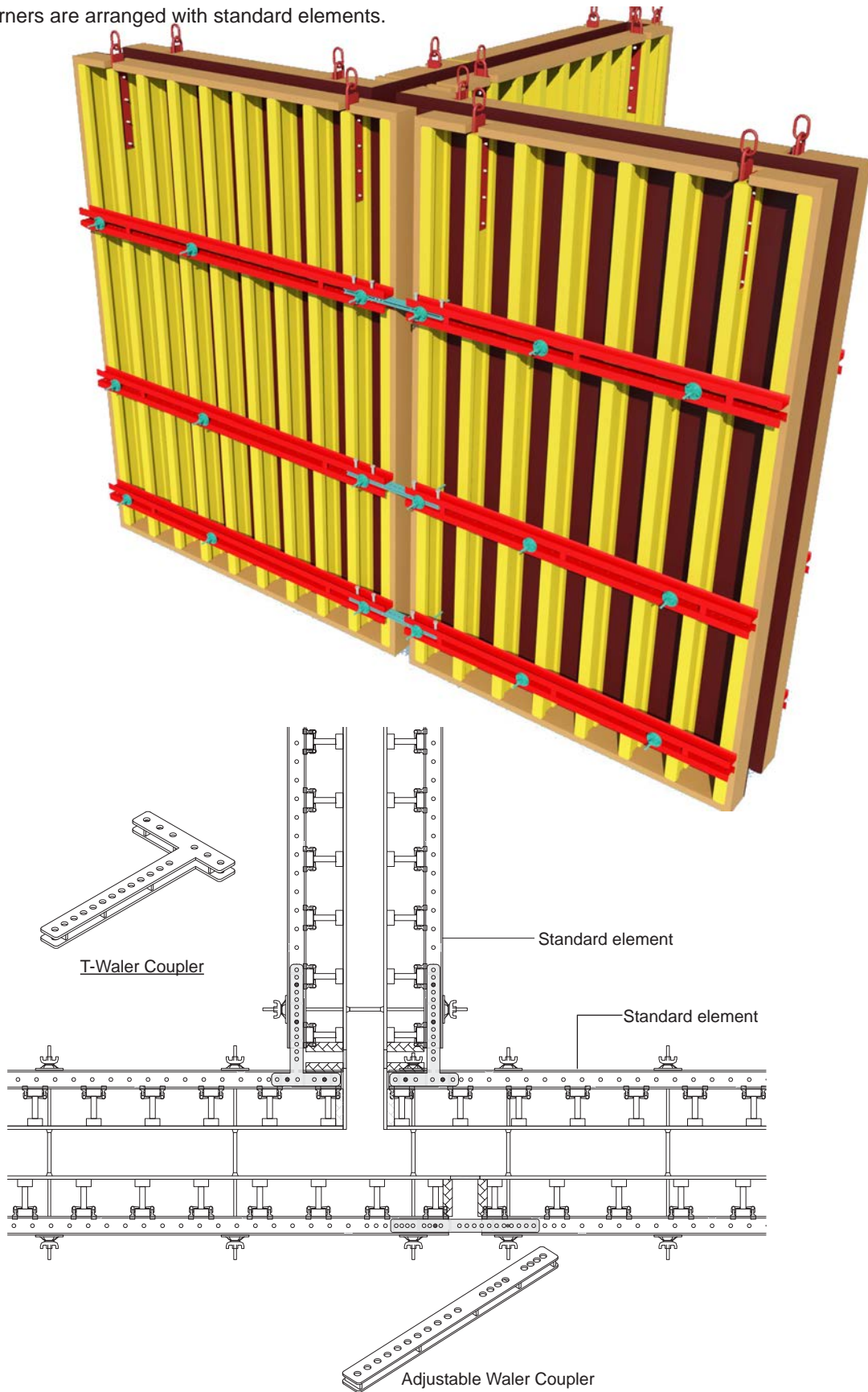

## Method of Statement

### Stopend Arrangement

The stopend is arranged at the wall ending, a construction joint or an extension joint.

For arranging the stopend element, The Waler Head Anchor U is fixed between the Walers using a connecting pin U 20x190. The loads from the concrete pressure are transferred by the Tie Rods into the Walers. Flange Nut 3 Wing 100 V permits a tension resistant connection and exact adjustment.

Depending on wall thickness, at least two H20 Timber Beams have to be used as stopend element.

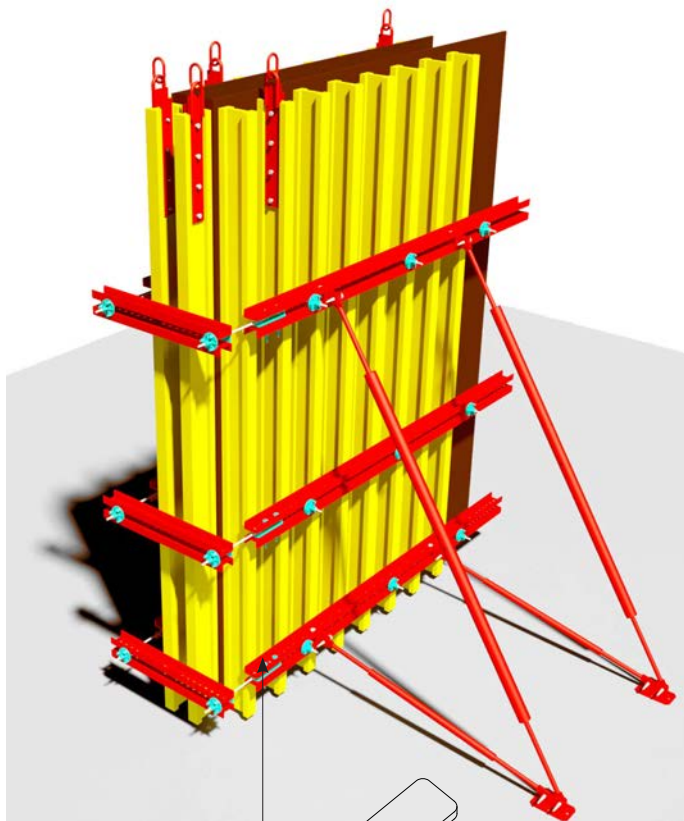
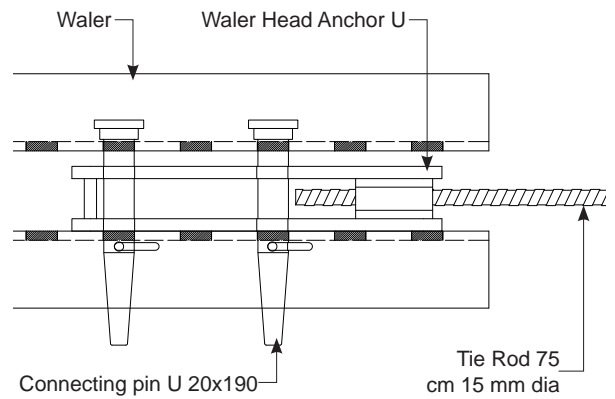

Waler Head Anchor U

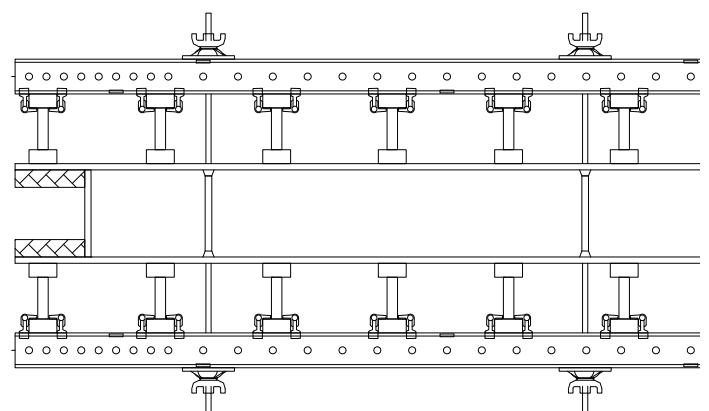
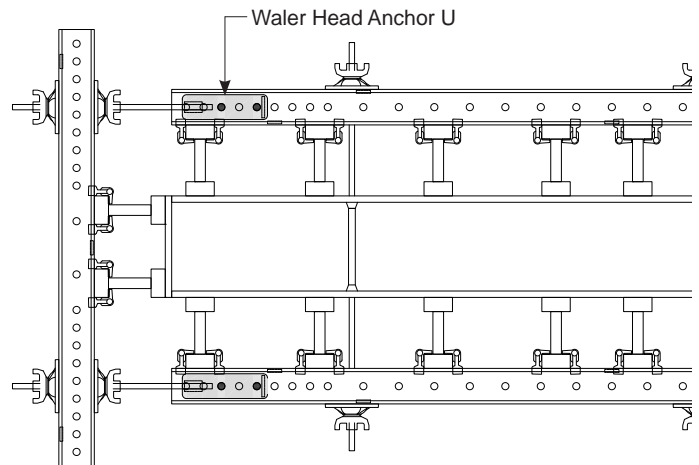

Method of Statement

Inner Corner

The erection of the inner corner is also possible by making use of T Waler Coupler in combination with Walers, H20 Timber Beams. The T Waler Coupler is fixed to the Waler by means of Connecting Pin.

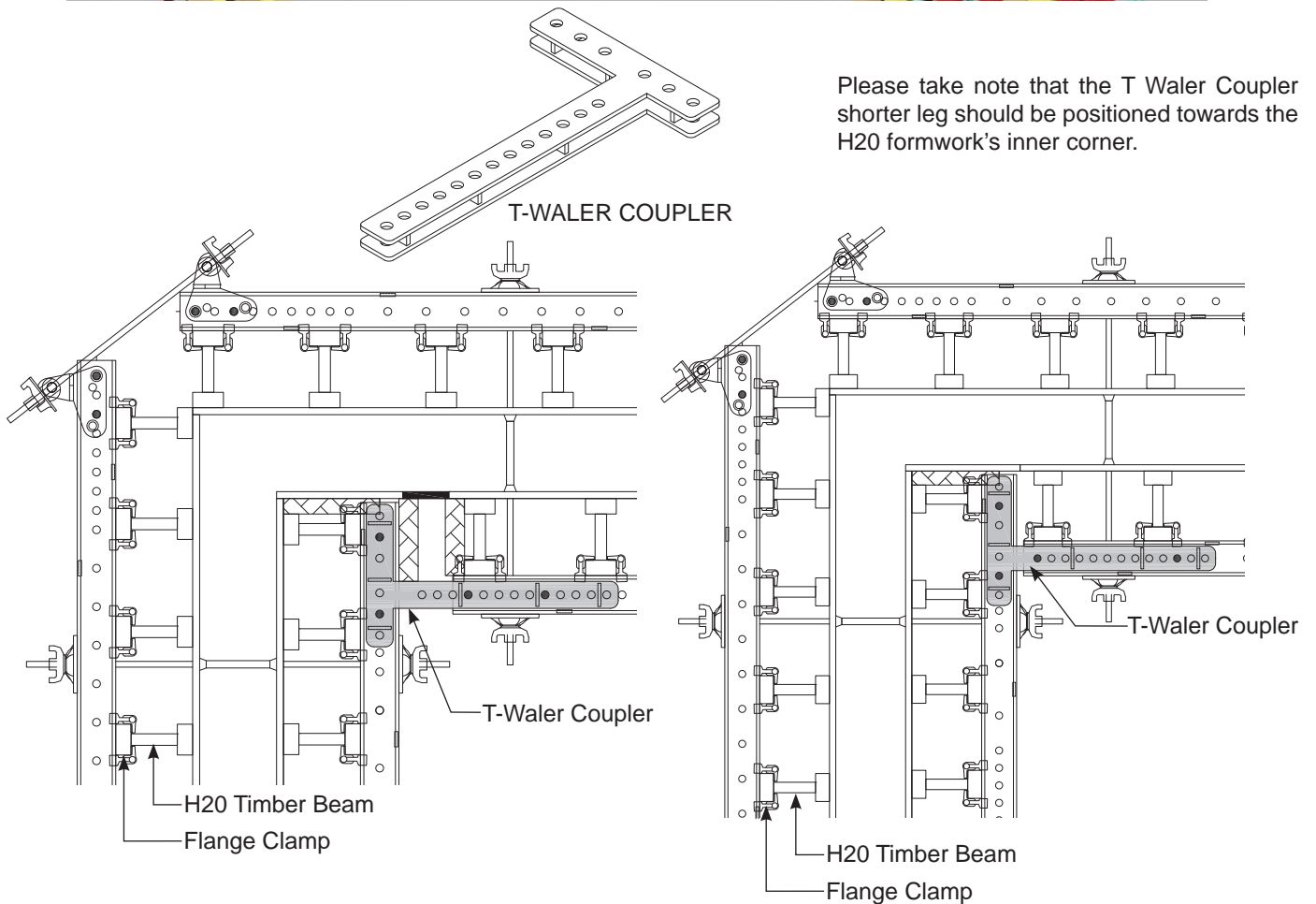
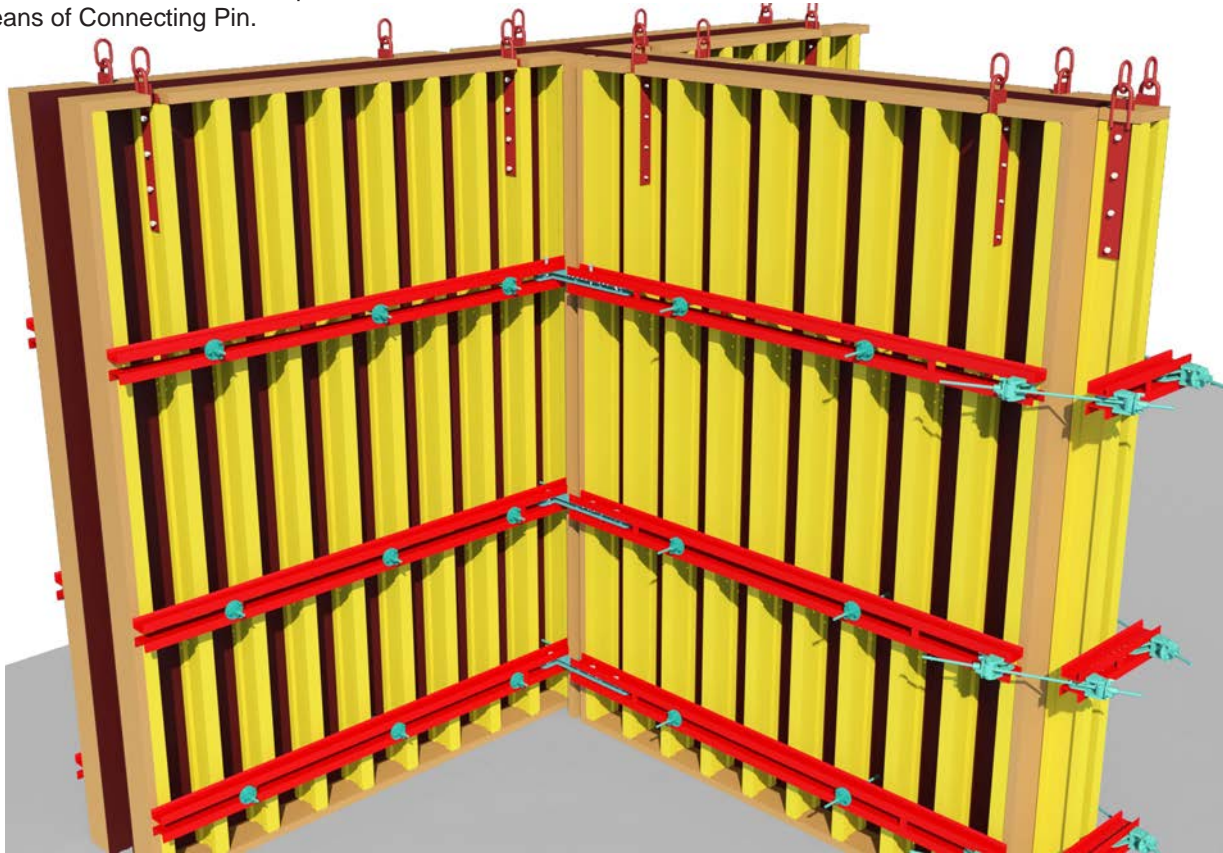

## Method of Statement

### Outer Corner

The standard outer corner is comprised with Outside Corner Yoke, Tie rod and Flange nuts. The Outside Corner Yoke U is fixed to the waler by means of Connecting Pin. Tightening at the corner should be done at 45 degrees angle to the Waler.

Please note that the application of Outside Corner Yoke U must be at a min. 40 degrees and max. 50 degrees.

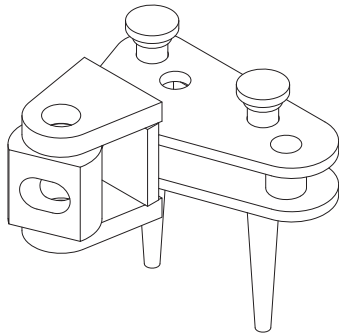

Outside Corner Yoke U

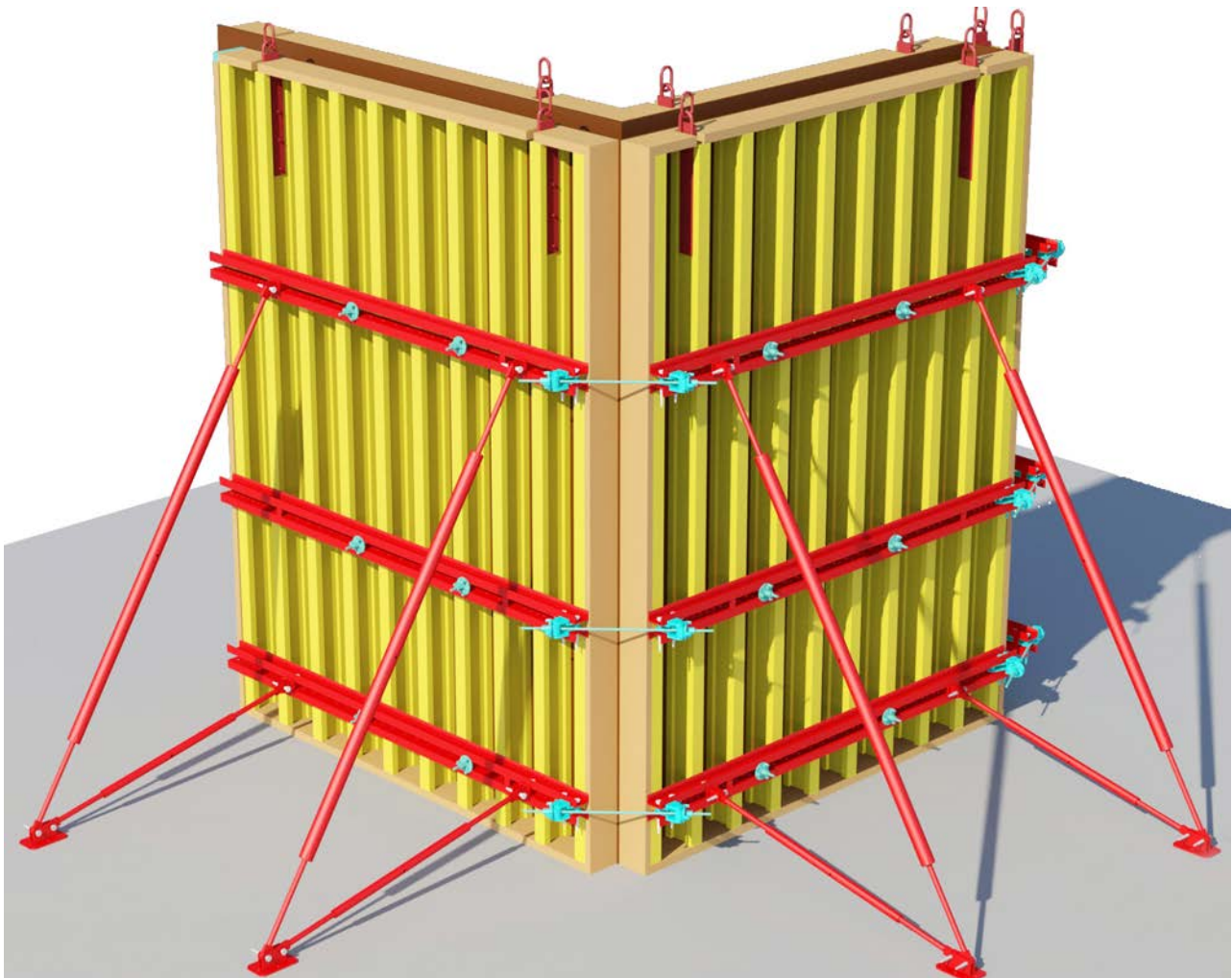
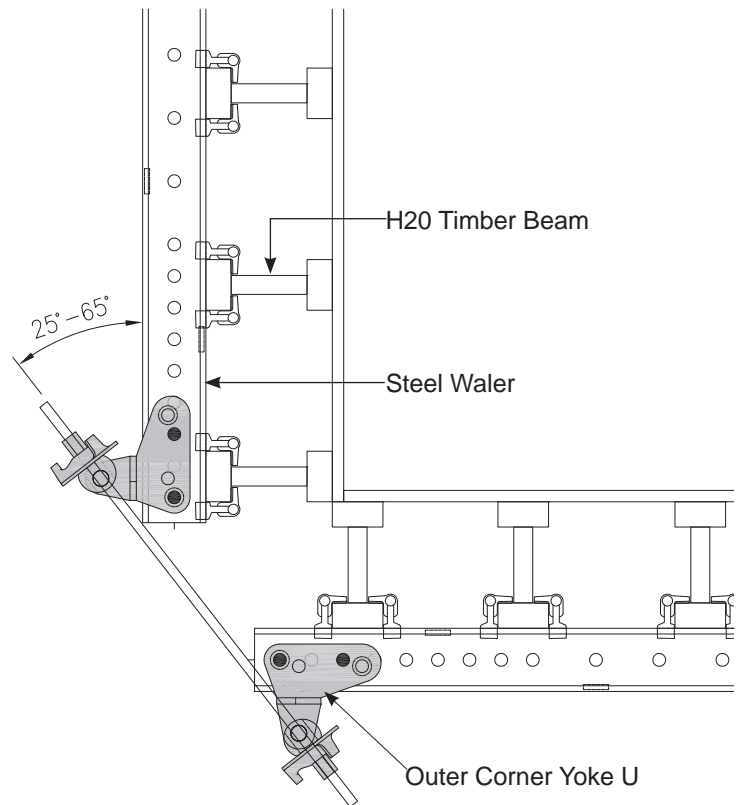

## Method of Statement

### Connection of the Wall Elements

Fixing of the wall elements by means of Waler Coupler and four Connecting Pin provides an aligned, tension and compression resistant wall element connection.

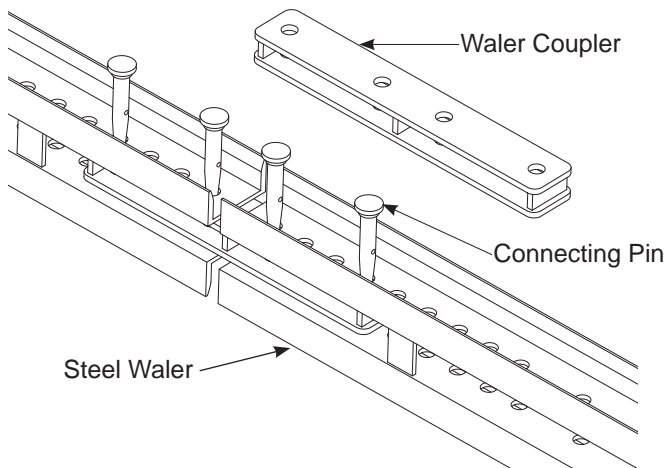

Waler Connector 165 is used together with length adjustment panels with a maximum width of 80 cm.

### Length Adjustment

For length adjustment, Adjustable Waler Coupler, Beam Coupler Plate and connecting Pin are to be used and fixed to the H2O Timber Beam.

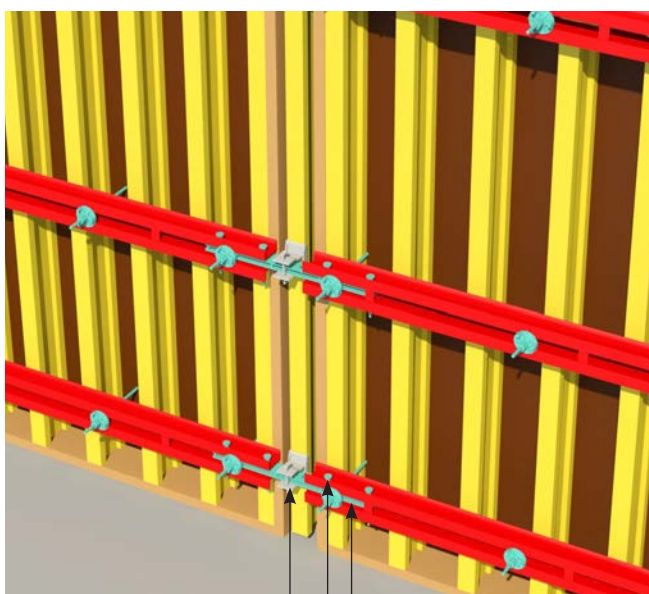

Beam Coupler Plate or Beam Fixing Device  
Waler Coupler  
Pin

A. The center of the Waler Coupler has to be placed in between the two adjacent wall elements and secured with Pin 1.

B. Place Pin 2 at a maximum distance from Pin 1 and fasten.

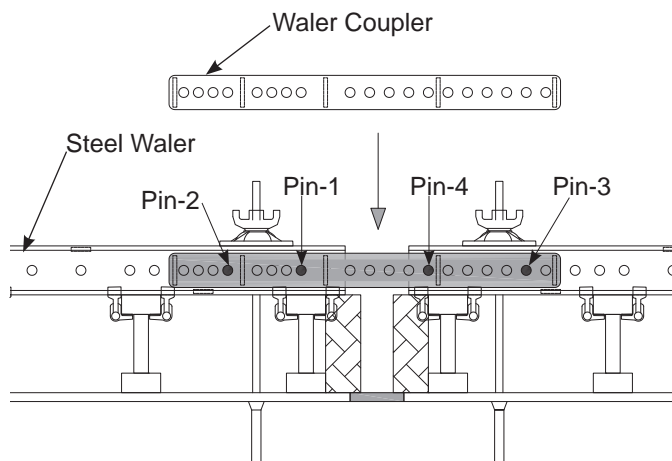

C. Insert Pin 3 and tighten element joint then fasten Pin 1 and Pin 3.

D. Pin 2 and Pin 4 have to be tightened as well.

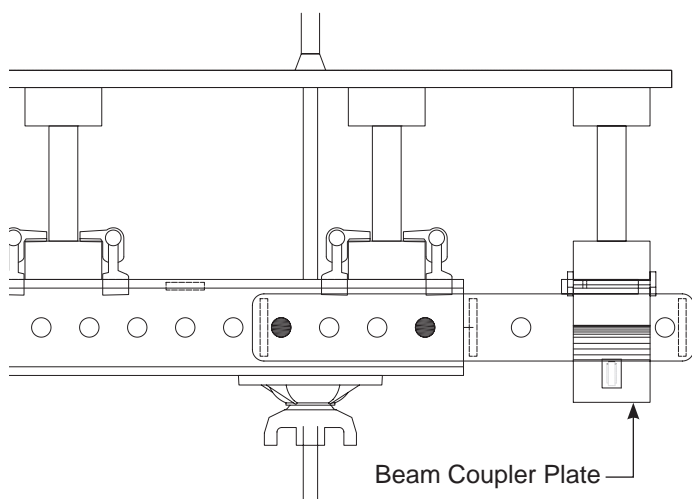

Beam Coupler Plate has a 6 mm dia. nail hole.

## Method of Statement

### Curve Arrangement

H2O Timber Beam elements arranged as circular wall shuttering can be connected by means of the Articulated Waler Coupler secured by inserting Connecting Pin 20X190 in the Waler.

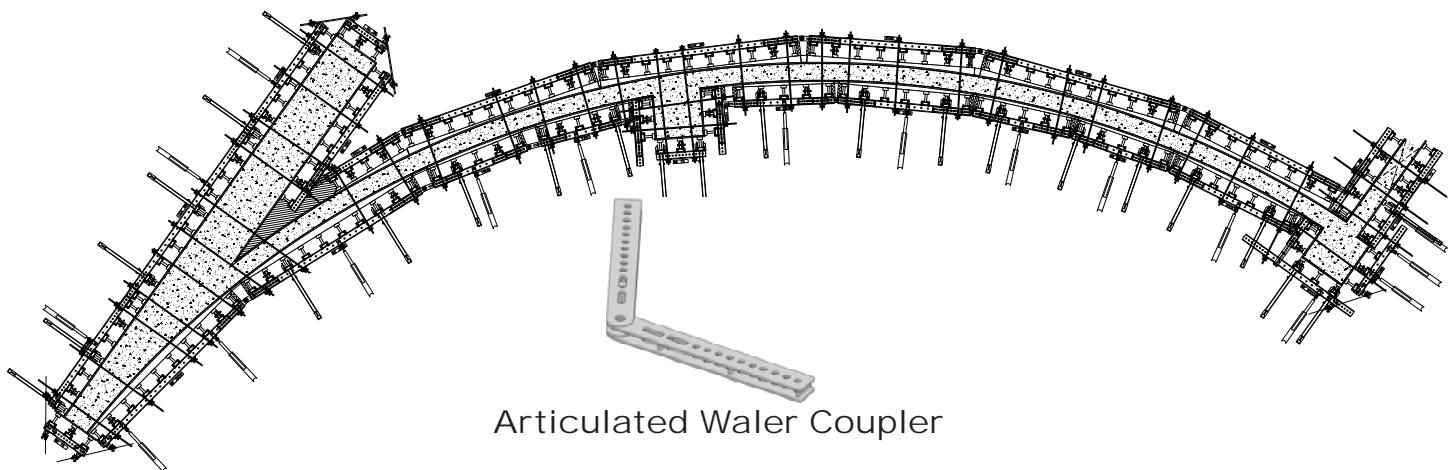
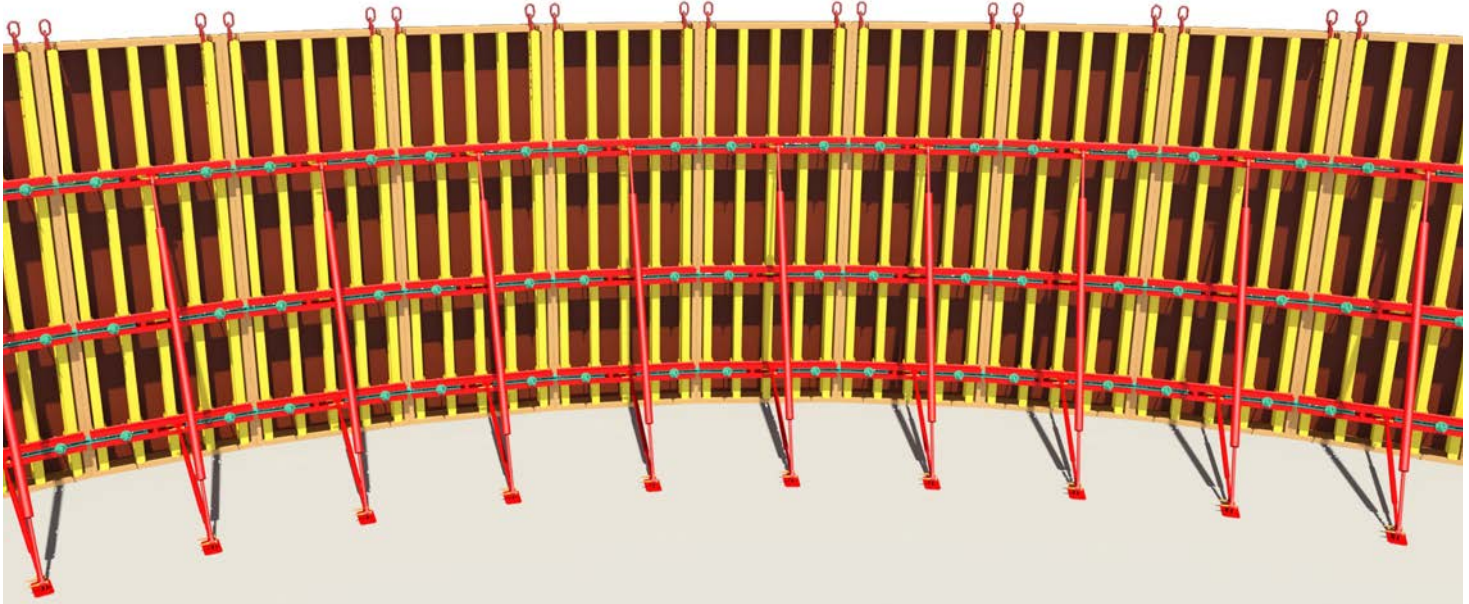

H2O Column

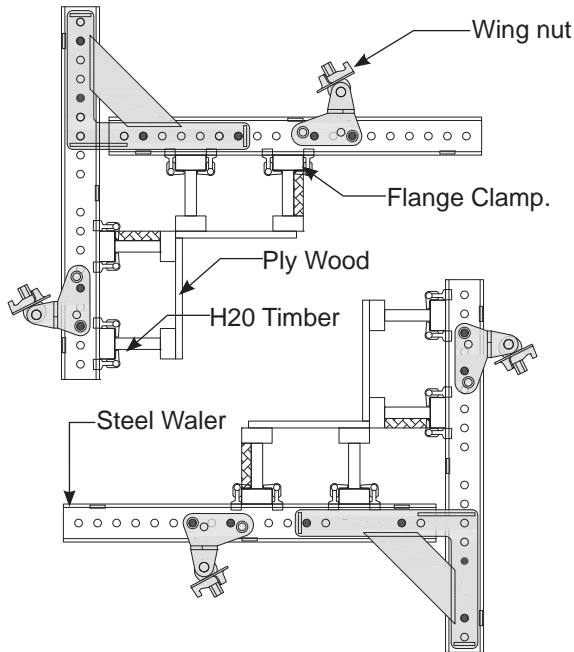
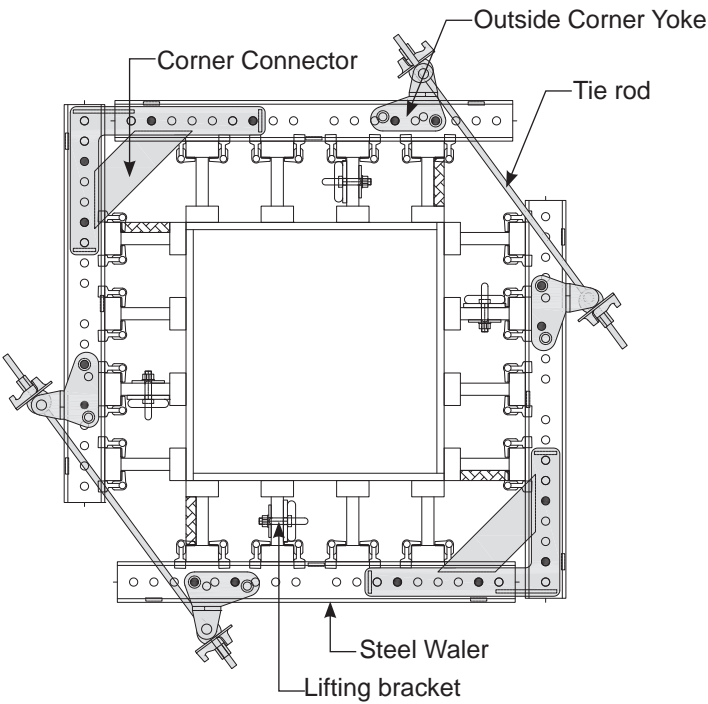
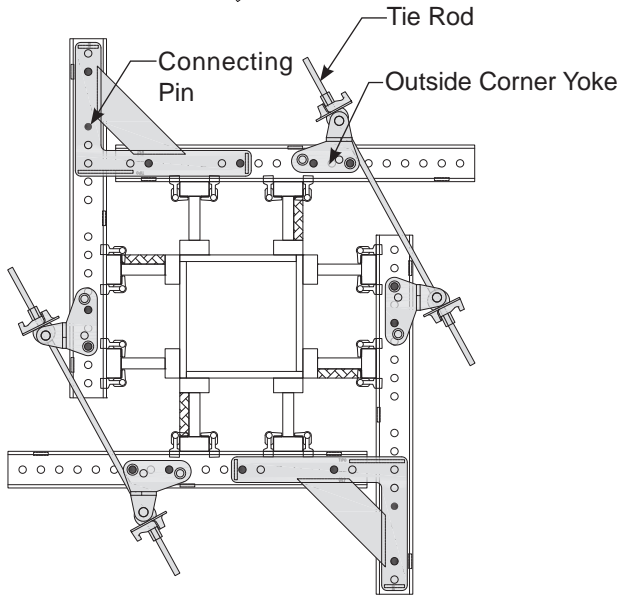
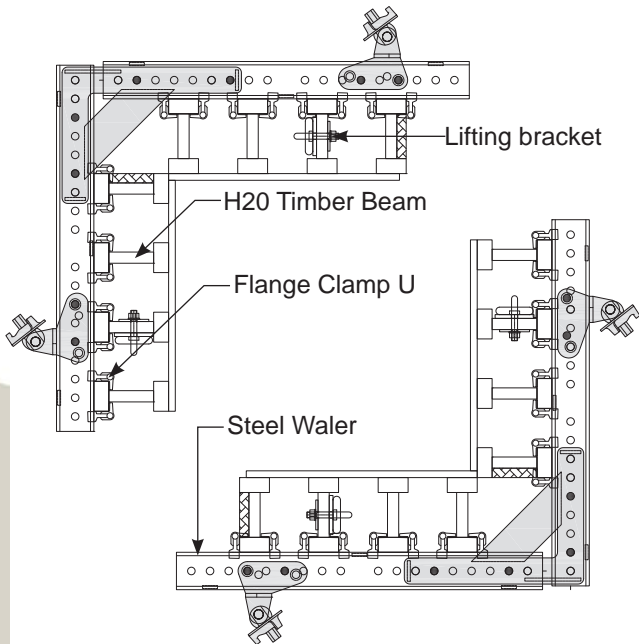
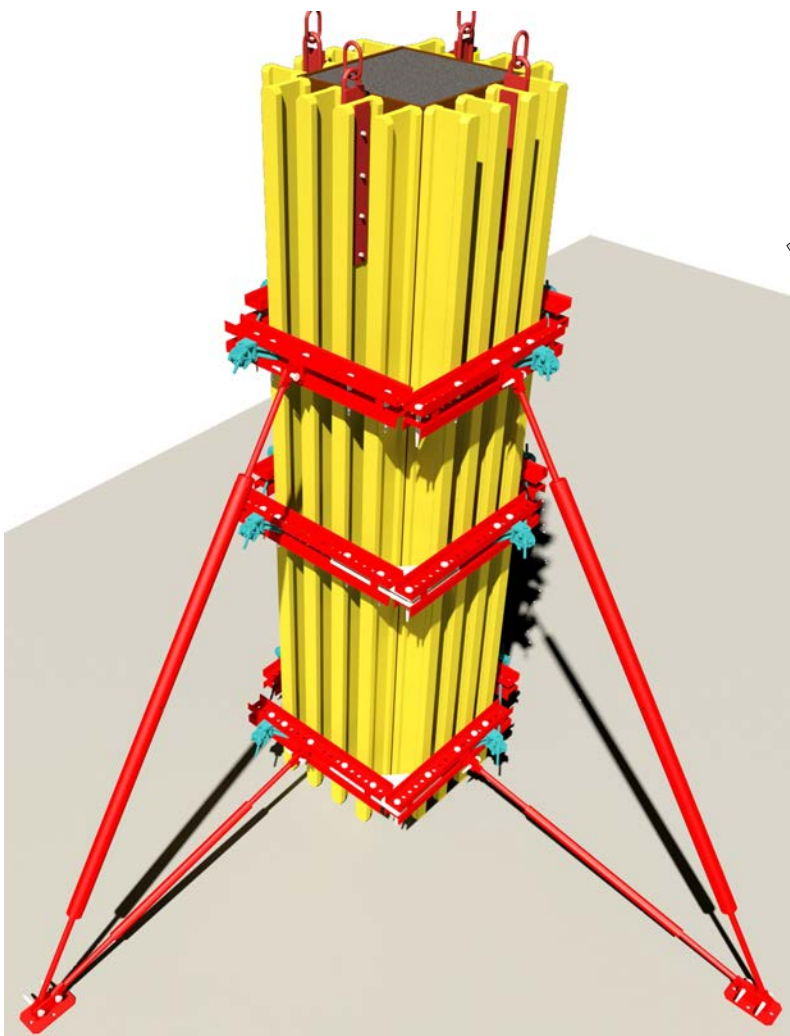

## Method of Statement

### Height Extension

The H20 Splice Plate is used to extend the height of the wall formwork's standard elements. By fixing the H20 Splice Plate to the web of the individual H20 Timber Beams, an aligned and rigid connection which is compression and tension resistant is achieved.

The H20 Splice Plate is fastened to the H20 Timber Beams using two H20 Splice Plate and four Bolts M20 x 80 with Nut.

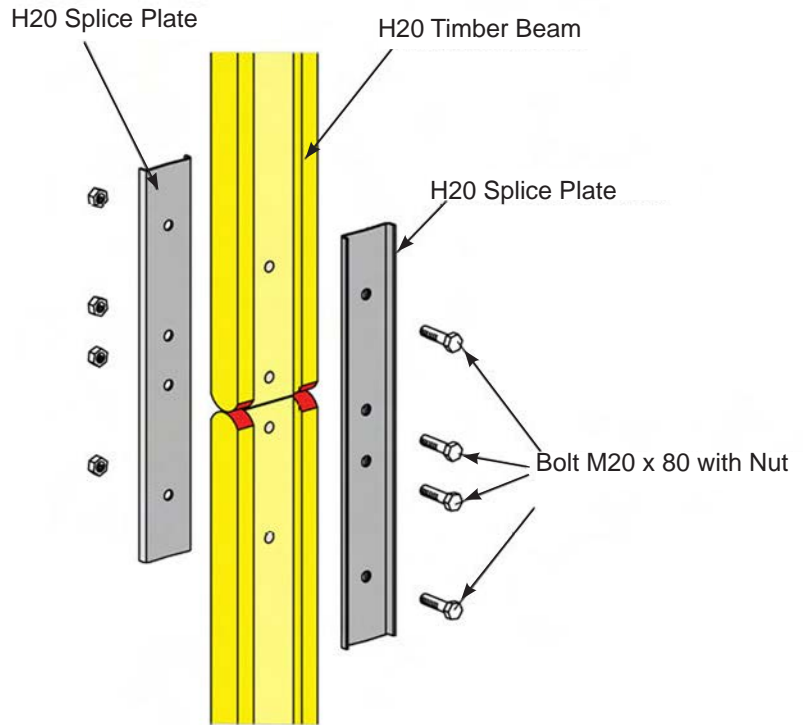
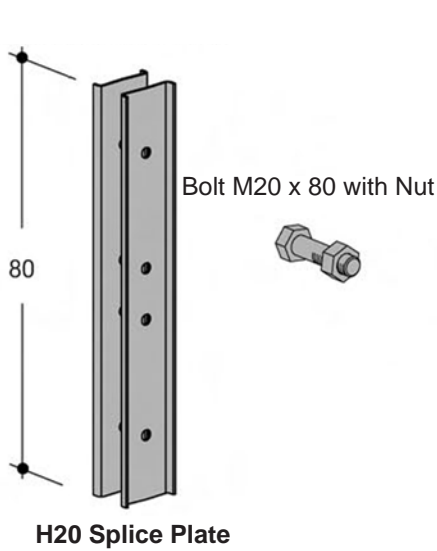

### Joined beam ends

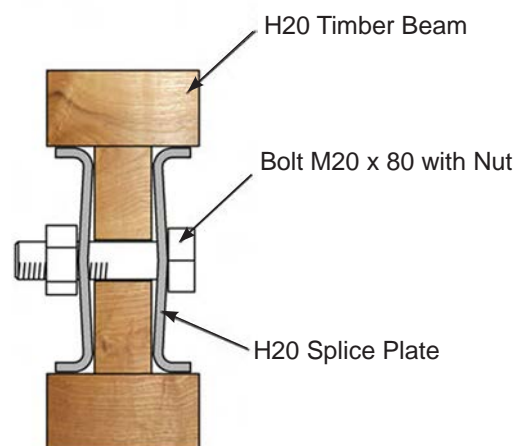
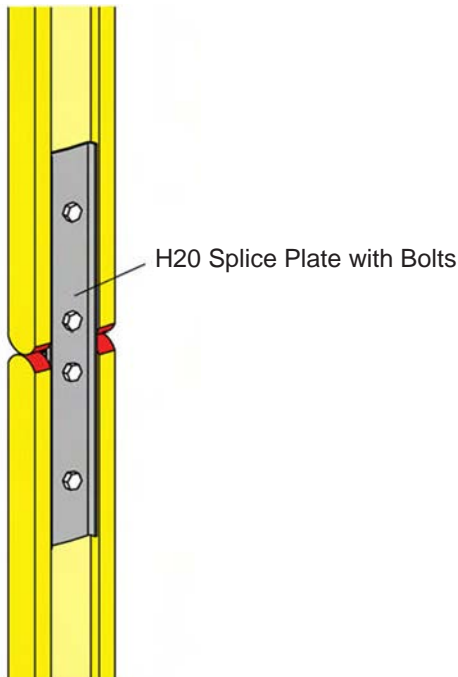

# Method of Statement

## Aligning the Wall Formwork Elements

### Arrangement of Push Pull Strut 1.1 - 1.7 & 2.4 - 3.5

Using the Push Pull Struts the wall formwork elements can be properly aligned and supported. During the erection of the wall shuttering, arrangement of the Push Pull Struts is necessary in order to take over the wind loads. The compression and tension resistant connection to the Waler is made by Push Pull Strut Head and Pin .

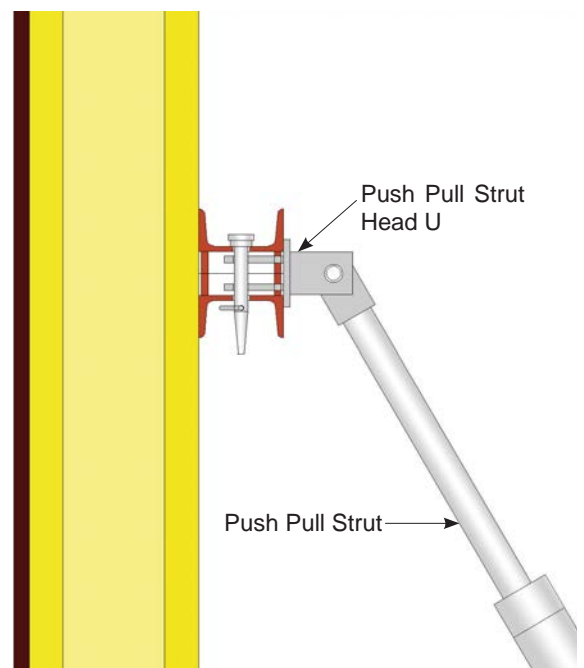
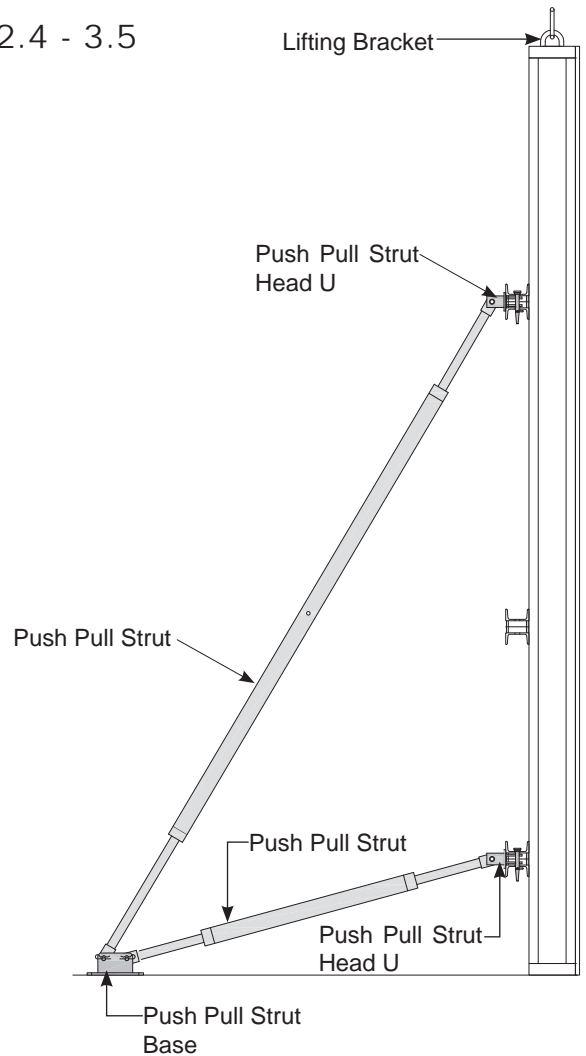
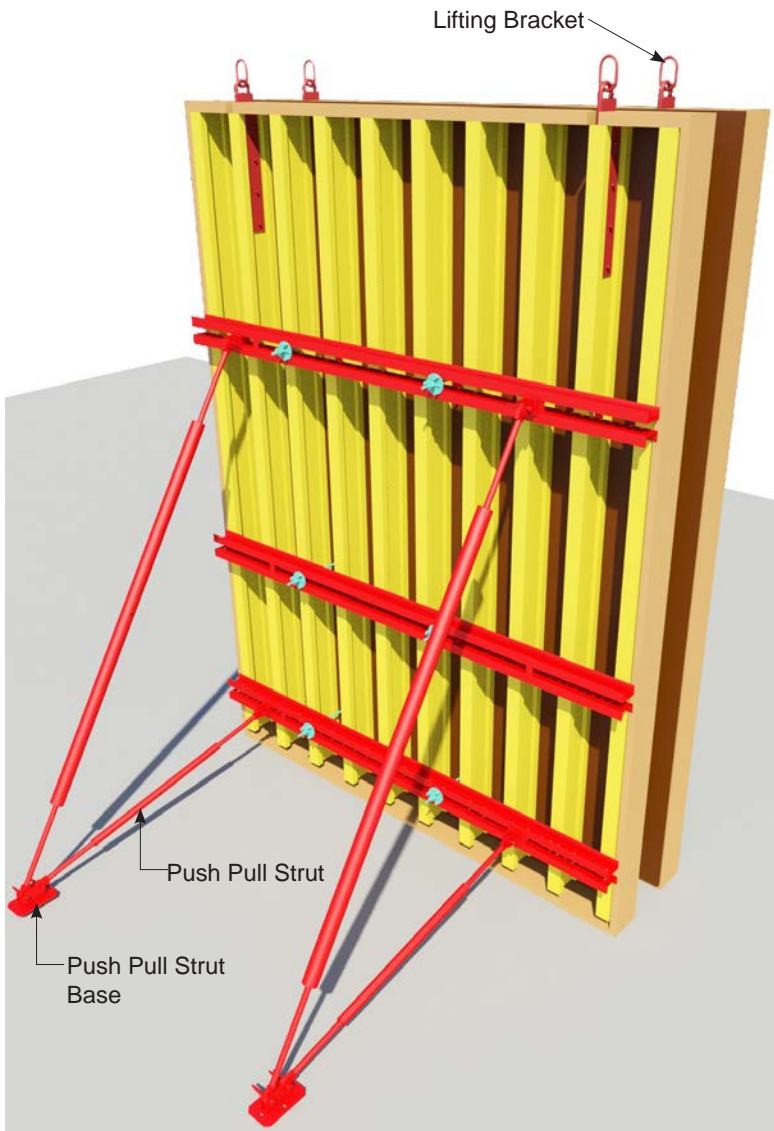

## Method of Statement

### Working Bracket Arrangement

The Working Bracket, which can be attached to the formwork in varied ways as described below, is a ready to use bracket which provides a working platform with a width of approximately 90cm. It is equipped with an additional Railing Post.

Prior to pre-assembly of the standard elements, holes with 20 mm diameter have to be drilled in the middle axis of the H20 Timber Beam web. These holes allows fastening of the Working Bracket using the Safety Pin.

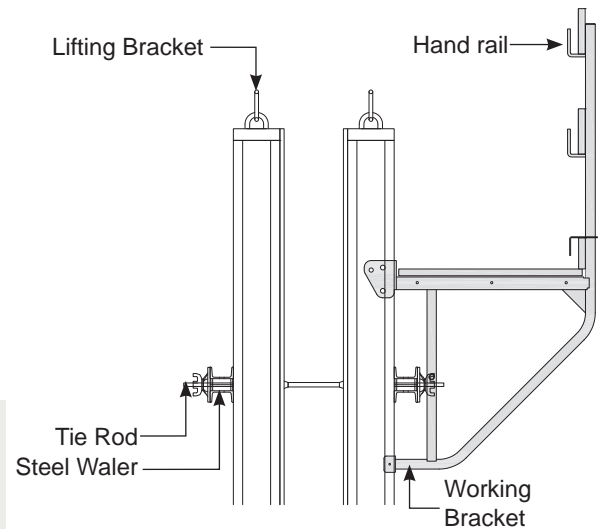
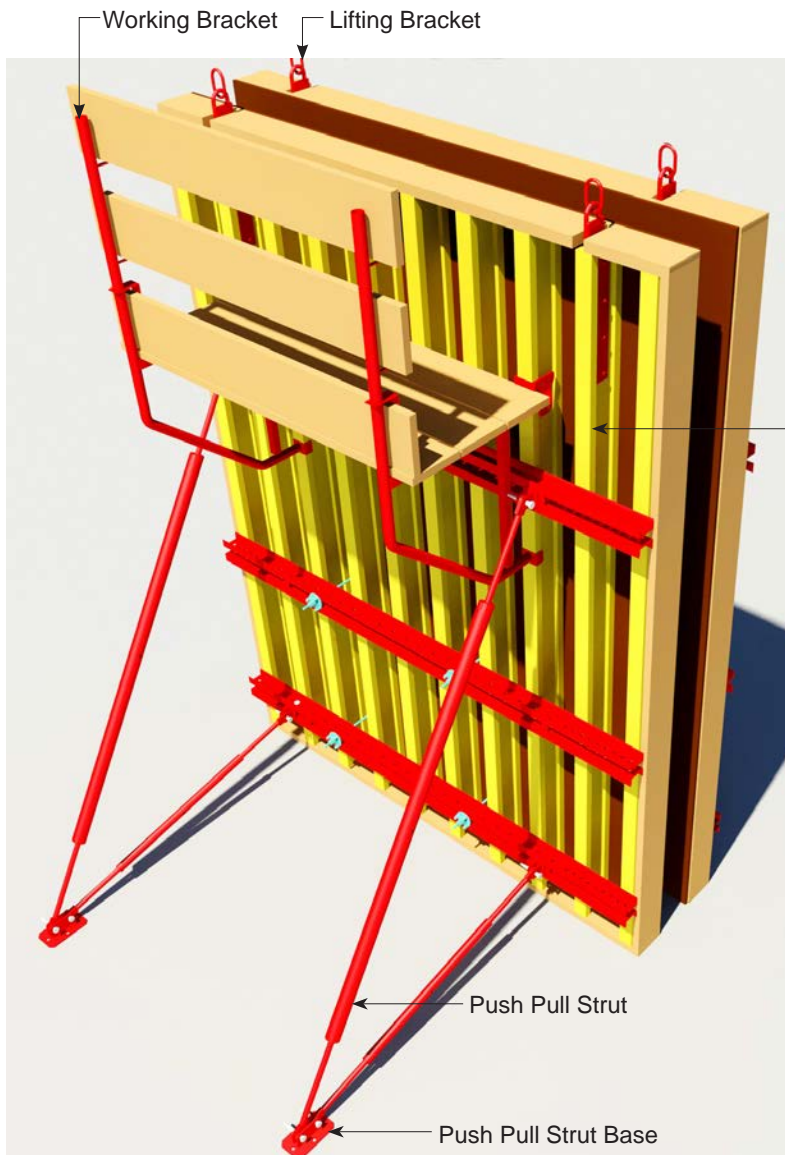

Working Bracket fixed with Timber

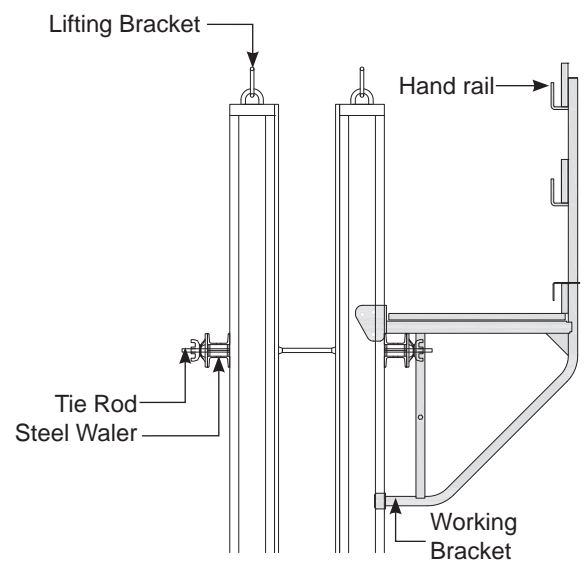

Working Bracket fixed with waler and rest on timber

Please note that the board thickness as well as dimension of the planks for the platform and railing should be in line with the specific construction and safety regulations on the site. The maximum distance of two Working Brackets should not exceed 1.50 m.

## Method of Statement

### Shifting of Panel

- Each Panel will have two Lifting Brackets
- The Lifting Bracket is fixed to the H20 Beam with 4 M 16 screws.
- The maximum working load for each Lifting Bracket is 1300 Kg (13 kN).
- This limit could be lower depending on the configuration of the panel.
- The maximum angle between the two chains of the Lifting Bracket is 60 degree.

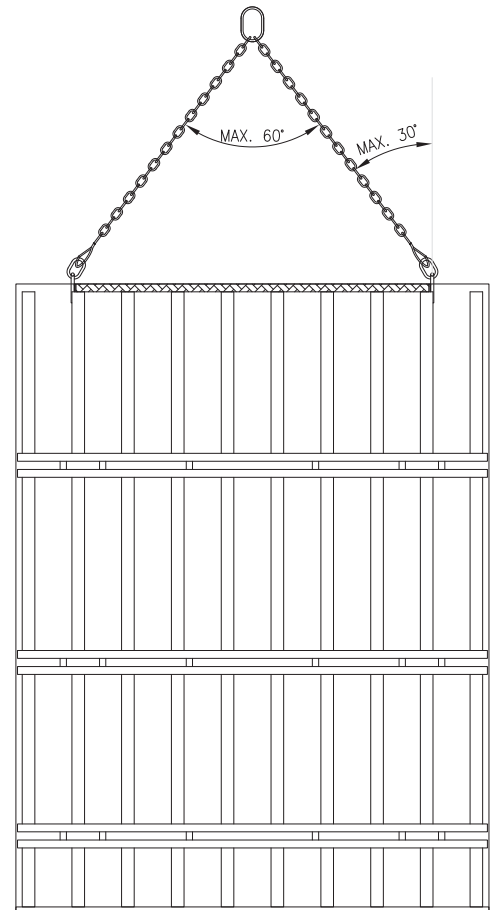
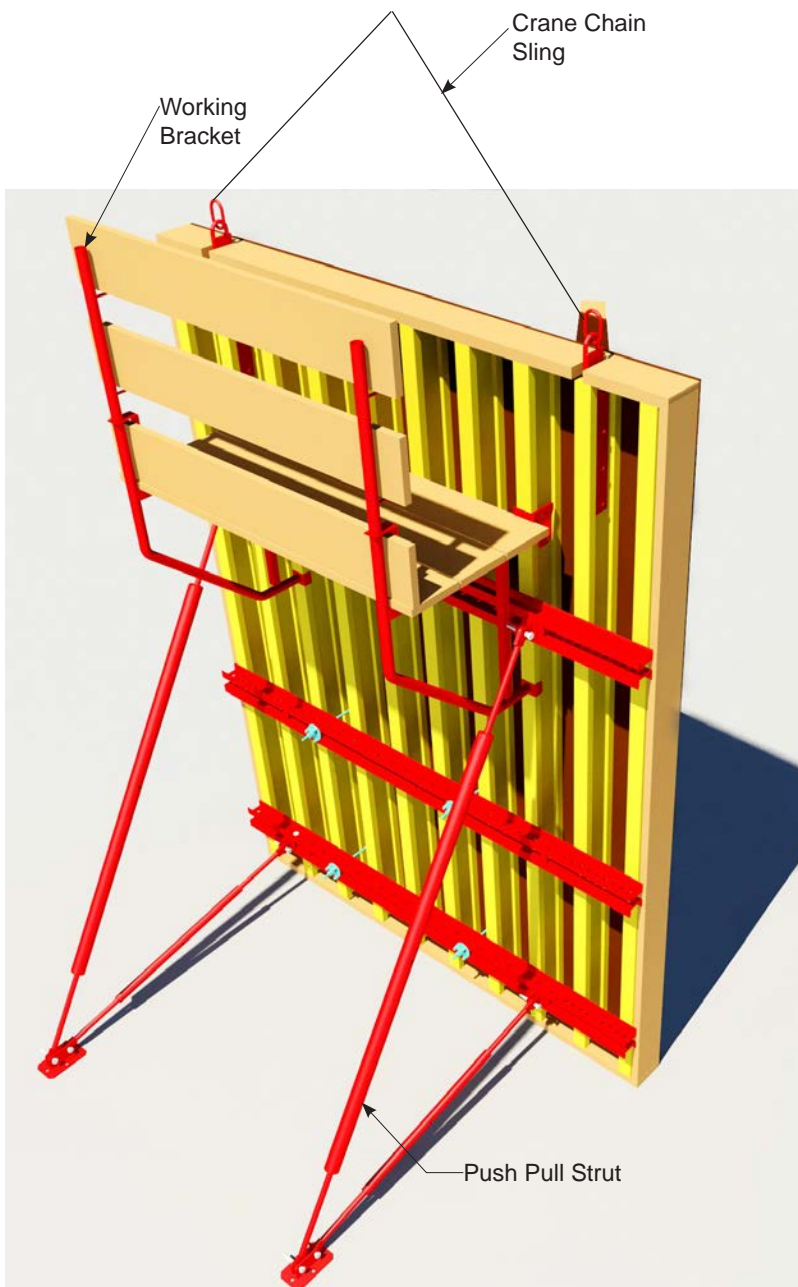

## Method of Statement

### De-shuttering Wall Formwork

#### Step-1

Fix the crane chain slings to H2O Panel (1-A) not attached to the Push Pull Struts Side. Ensure slings angle does not exceed 60°. Take up the slack in the chain without taking the weight of the panel

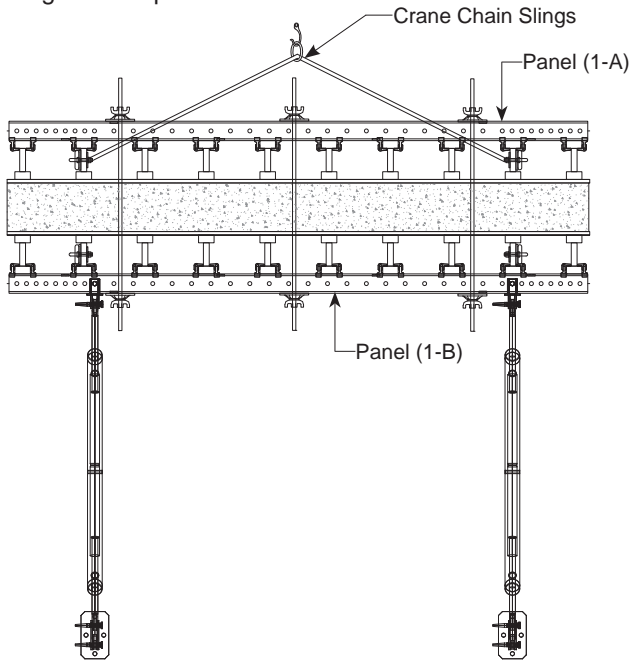

#### Step-3

Retract H2O panel (1-A) from the wall.  
Carefully retract the shutter from the concrete surface using pinch bar

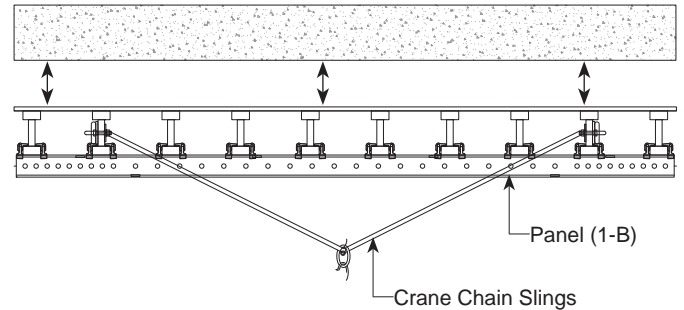

#### Step-2

Remove and set aside all flange nut and tie rods from the panels

Ensure that all the accessories connected to the adjacent H2O Panels are removed and separated from H2O Panel (1-A).

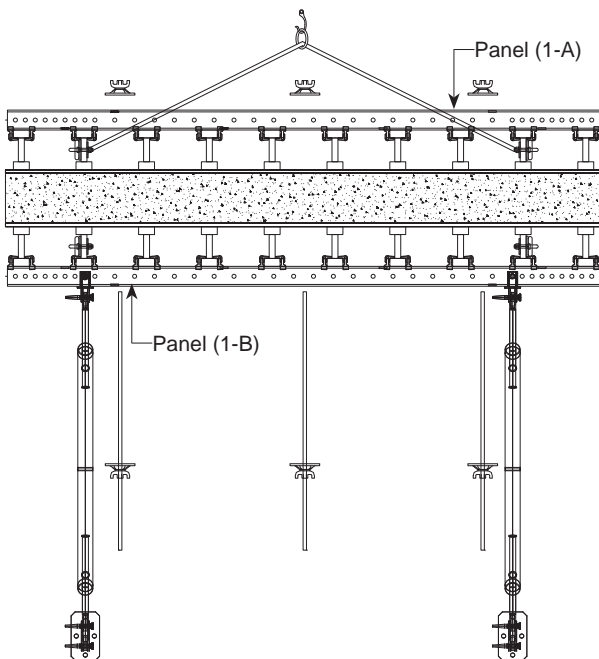

#### Step-4

Lift and remove the retracted panel

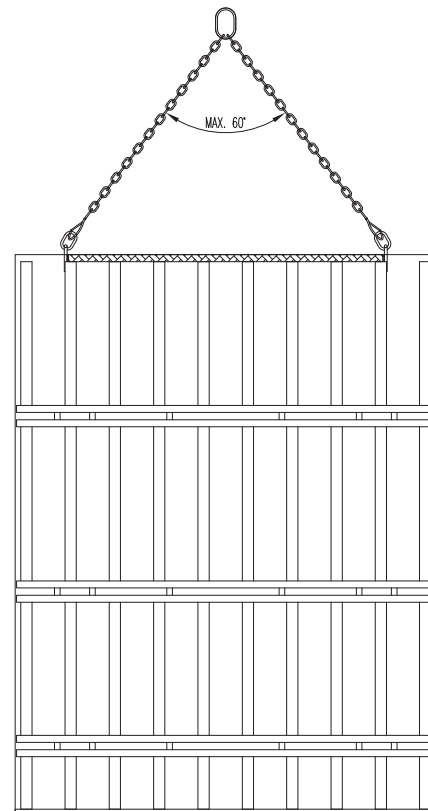

## Method of Statement

### De-shuttering Wall Formwork

#### Step-5

Fix the crane chain sling to H2O Panel (1-B) attached to the Push Pull Prop. Ensure sling angle does not exceed 60°. Ensure that all the accessories that connected to the adjacent H2O Panel are removed and separated from H2O Panel (1-B)

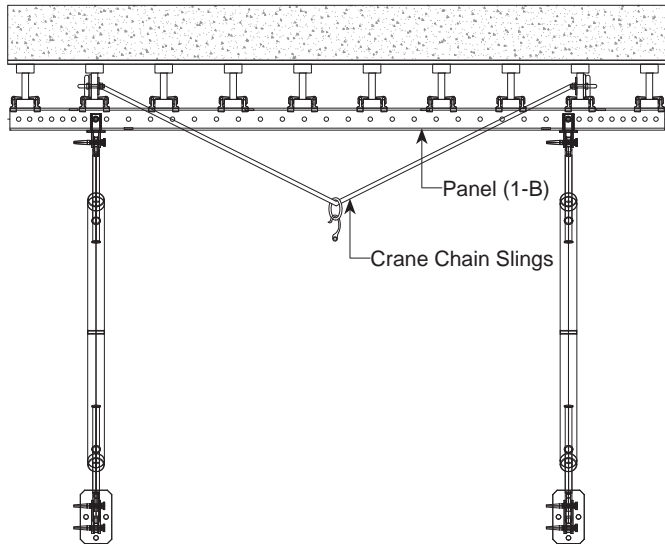

#### Step-6

Remove Push Pull Strut.

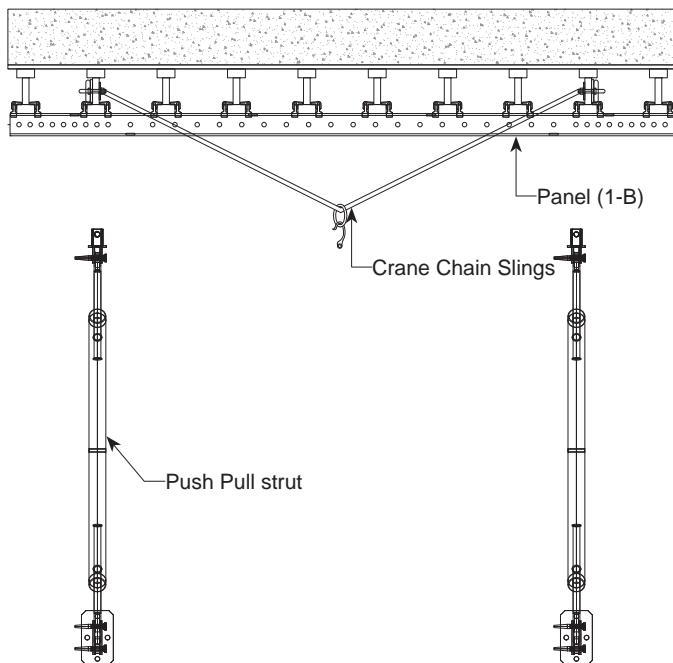

#### Step-7

Retract H2O panel (1-B) from wall.

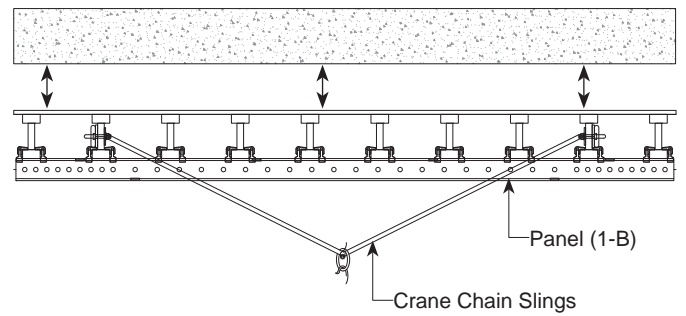

#### Step-8

Lift and remove the retracted panel

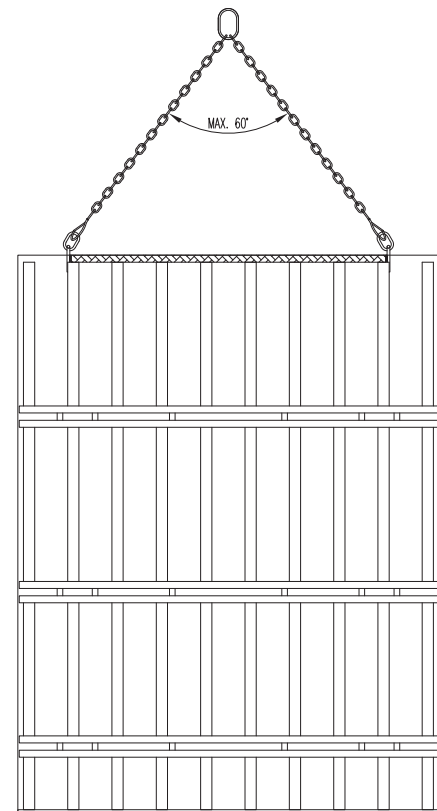

Repeat the following steps for the Adjacent H2O Panels

# Steel Column Panel

Easy & Durable Column System



Column system is composed by a steel painted framed with a layer of Finnish birch plywood 18mm thickness, protected by a thermosetting phenolic resin (220g/m<sup>2</sup>) or of a thermoplastic layer PVC material, applied on it.

The heights of the single panels are modular (3.00m, 1.50m and 0.75m) in order to provide the proper formwork height.

Thanks to the locking pins that are assembled inside the steel frame (replaceable), this system allow adjustment of 5cm each step, starting from a minimum size of 20x20cm to a maximum size of 105x105cm. The fresh concrete pressure capacity is 80 kN/Sqm.

The retractable pins slides in and out to the opposite panel through a PVC

bushings installed in the plywood since the manufacturing of the panels. This allow at least **150-200 times of repetition with correct oil.**



# Overview

- 1. Steel Column Panel
- 2. Vito Tie Nut
- 3. Locking Pin
- 4. Rod Adjustable

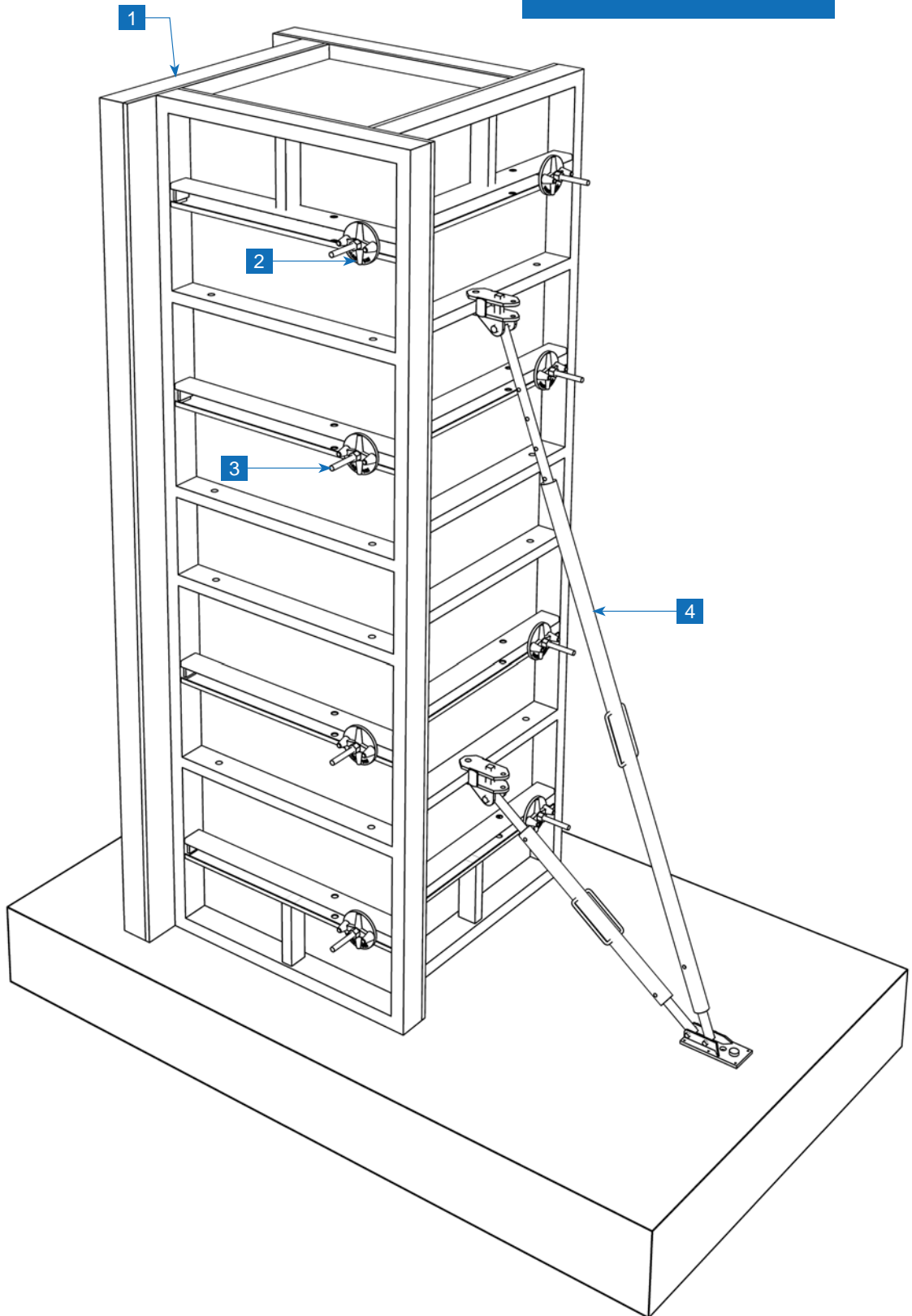

Description Art. No Weight

Steel Column Panel

Column Panel 3000x1000x100	0300100	136.00
Column Panel 1500x1000x100	0150100	65.00
Column Panel 750x1000x100	0750100	40.00
Column Panel 3000x750x100	0300750	102.00
Column Panel 1500x750x100	0150750	55.00
Column Panel 750x750x100	0750750	30.00

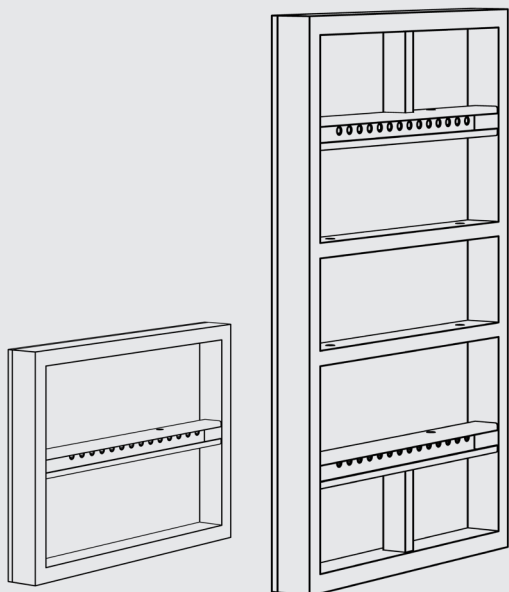

Circular Column formwork for Height 500mm

Diameter	Art. No	Weight
200	C200500	33.00
250	C250500	37.00
300	C300500	40.00
350	C350500	44.00
400	C400500	48.00
450	C450500	54.00
500	C500500	62.00
550	C550500	67.00
600	C600500	71.00
650	C650500	76.00
700	C700500	80.00
750	C750500	84.00
800	C800500	88.00
850	C850500	92.00
900	C900500	97.00
950	C950500	101.00
1000	C1000500	105.00
1100	C1100500	140.00

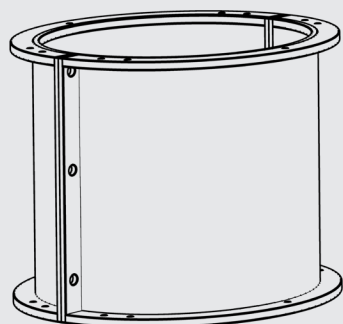

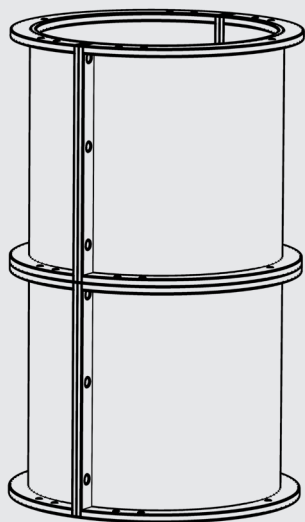

Circular Column formwork for Height 1000mm

Diameter	Art. No	Weight
200	C2001000	54.00
250	C2501000	59.00
300	C3001000	64.00
350	C3501000	70.00
400	C4001000	76.00
450	C4501000	82.00
500	C5001000	92.00
550	C5501000	99.00
600	C6001000	105.00
650	C6501000	112.00
700	C7001000	118.00
750	C7501000	124.00
800	C8001000	151.00
850	C8501000	158.00
900	C9001000	166.00
950	C9501000	173.00
1000	C10001000	180.00
1100	C11001000	222.00

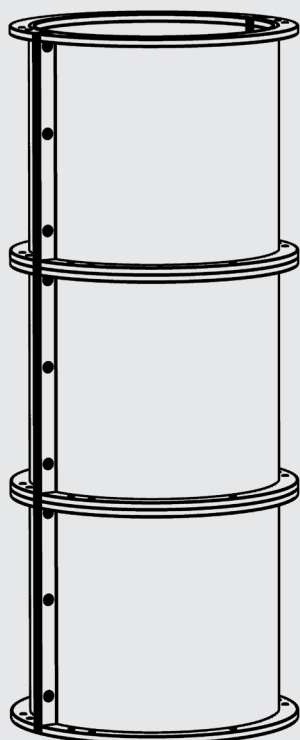

Circular Column formwork for Height 1500mm

Diameter	Art. No	Weight
200	C2001500	81.00
250	C2501500	89.00
300	C3001500	97.00
350	C3501500	105.00
400	C4001500	114.00
450	C4501500	121.00
500	C5001500	136.00
550	C5501500	146.00
600	C6001500	155.00
650	C6501500	164.00
700	C7001500	173.00
750	C7501500	180.00
800	C8001500	194.00
850	C8501500	203.00
900	C9001500	212.00
950	C9501500	221.00
1000	C10001500	230.00
1100	C11001500	272.00

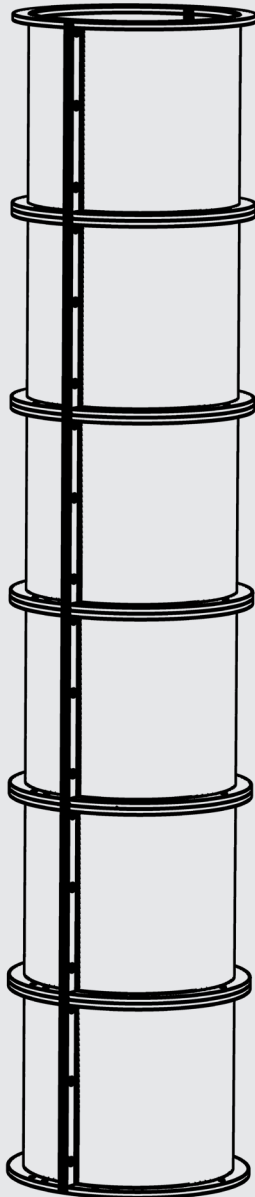

Description

Art. No

Weight

Circular Column formwork for  
Height 3000mm

Diameter	Art. No	Weight
200	C2003000	147.00
250	C2503000	162.00
300	C3003000	178.00
350	C3503000	193.00
400	C4003000	208.00
450	C4503000	223.00
500	C5003000	247.00
550	C5503000	266.00
600	C6003000	282.00
650	C6503000	298.00
700	C7003000	314.00
750	C7503000	331.00
800	C8003000	389.00
850	C8503000	408.00
900	C9003000	426.00
950	C9503000	445.00
1000	C10003000	463.00
1100	C11003000	593.00

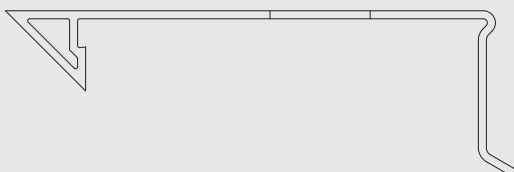

Chamfer Strip

Chamfer Strip 3000	1758241	1.80
Chamfer Strip 1500	1758242	0.90
Chamfer Strip 750	1758243	0.45

System Components

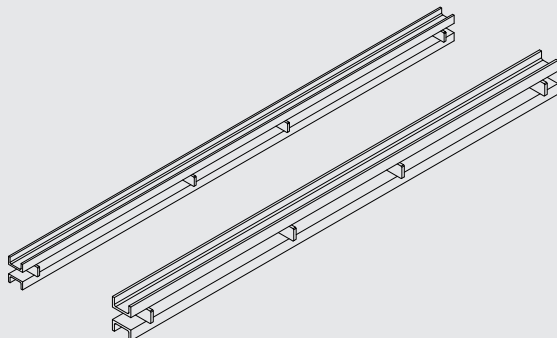
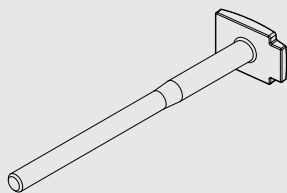
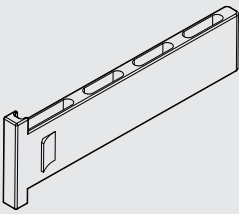
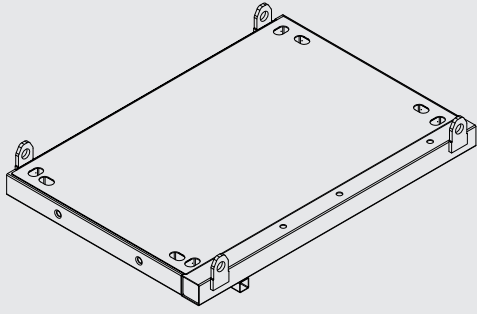
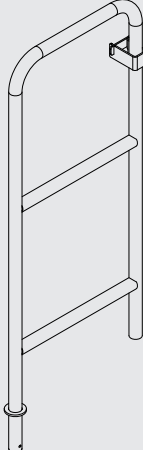
	Description	Art. No	Weight
	<p>Hinge Striker</p> <p>Column Panel 100</p> <p>Column Panel 75</p>	<p>1758244</p> <p>1758245</p>	<p>21.00</p> <p>16.00</p>
	<p>Locking Pin</p>	<p>1758246</p>	<p>0.90</p>
	<p>Locking Pin Stop</p>	<p>1758247</p>	<p>0.065</p>
	<p>Concreting Platform for Columns</p>	<p>1758248</p>	<p>58.00</p>
	<p>Moveable Handrail</p>	<p>1758249</p>	<p>7.50</p>

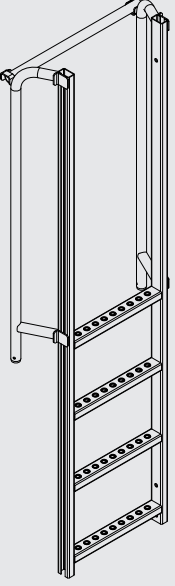
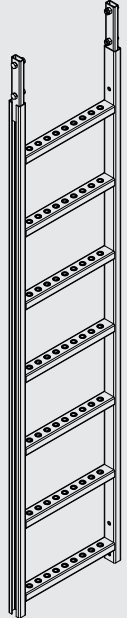
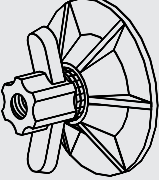
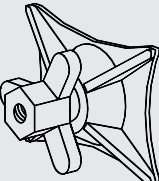
	Description	Art. No	Weight
	Top Ladder	1758250	17.00
	Bottom Ladder	1758251	13.50
	Vito Tie Nut	600247	1.30
	Tie Nut 230	600248	2.50

System Components

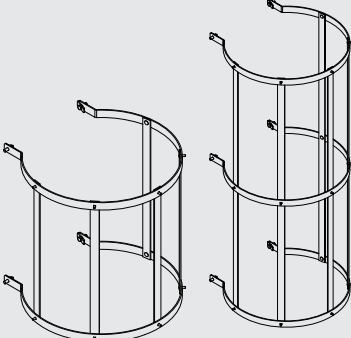
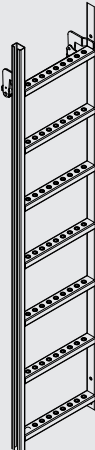
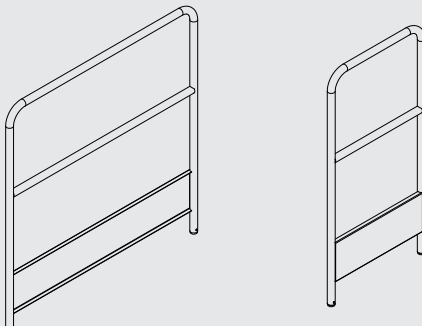
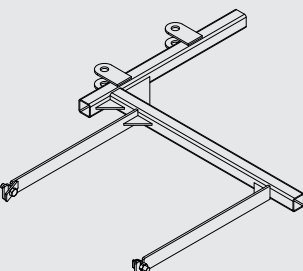
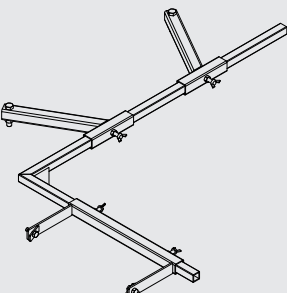
	Description	Art. No	Weight
	Ladder Safety Cage	1758252 1758253	23.00 12.00
	Removable Ladder	1758254	13.00
	Platform Handrail Short	1758255 1758256	8.50 9.70
	Ladder stirrup	1758257	5.20
	Ladder Stirrup for circular column	1758258	11.70

System Components

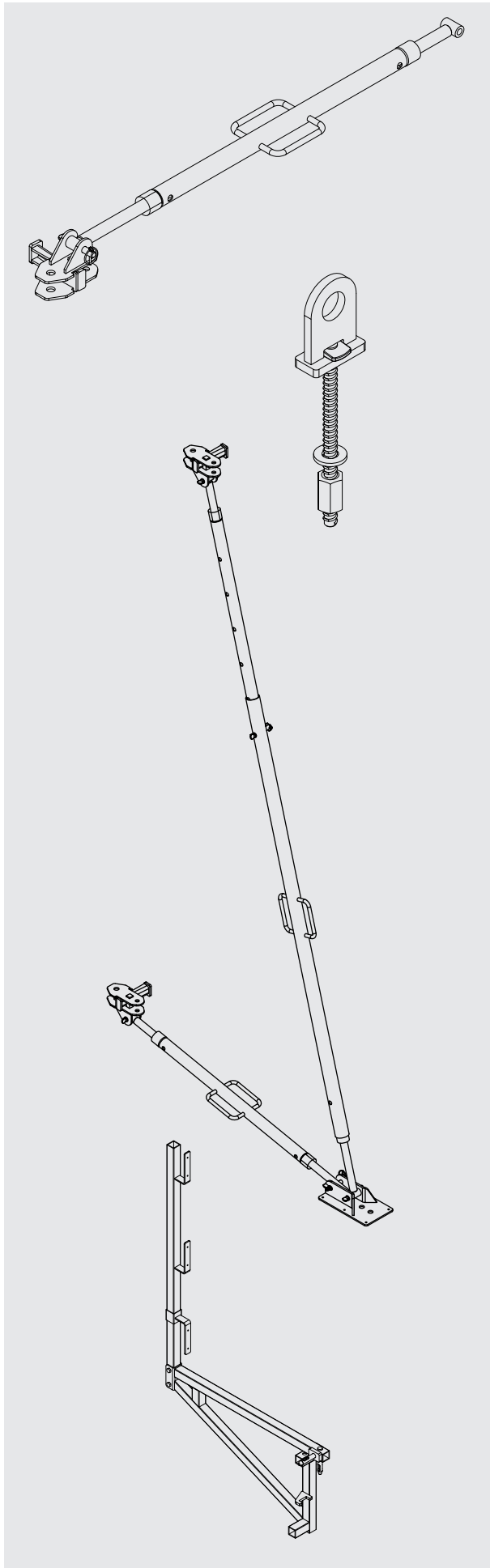

Description	Art. No	Weight
-------------	---------	--------

Horizontal strut with threaded ends	1758259	12.00
-------------------------------------	---------	-------

Lifting Hook	1758260	13.00
--------------	---------	-------

Rod Adjustable		
Rod Adjustable 2500-4500	1758261	39.00
Rod Adjustable 4000-6500	1758262	60.00
Rod Adjustable 6000-9000	1758263	180.00
Rod Adjustable 12200-14500	1758264	340.00

Service console	1758265	12.30
-----------------	---------	-------

# SS Support Frame (HD System)

Quick & Easy Wall System



## Product Features

Single Sided Support Frame consist of basic items such as Single Sided Support Frame 500, Lower Part 200 and Base Frame 200/2 enables height extension of up to 8.6 m. The system is designed for a permissible concrete pressure of up to 60 kN/m<sup>2</sup> • The distance between the support frames is calculated and designed according to the wall height and concrete pressure.

The vertical double U steel profile of the system allows usage of any type of the wall formwork system. The support frames are equipped with integrated Base Jacks which allows the alignment of the structure.

The loads resulting from the pouring of the walls are transferred by the frames into the base structure through the cast-in loop tie anchors at the front base of the formwork and through the compressive jacks at the rear of

the Single Sided Support Frames. Therefore, it is essential to determine whether the structural components such as base slabs or foundations are capable to carry these loads. Moreover, the opposite side of the single sided wall formwork (either existing structural parts or shoring) must be able to carry the concrete pressure as well.

The arrangement of the loop ties and distances between the permanent anchors must be determined based on the calculated statical values and the anchors must be positioned as accurately as possible prior to pouring the floor slab.



# Overview

1. Supporting Frame UVR
2. Steel Waler
3. H20 panel
4. Loop Tie
5. Flange Nut 3 Wing
6. Waler Holder Hook
7. Working Bracket
8. Lifting Hook

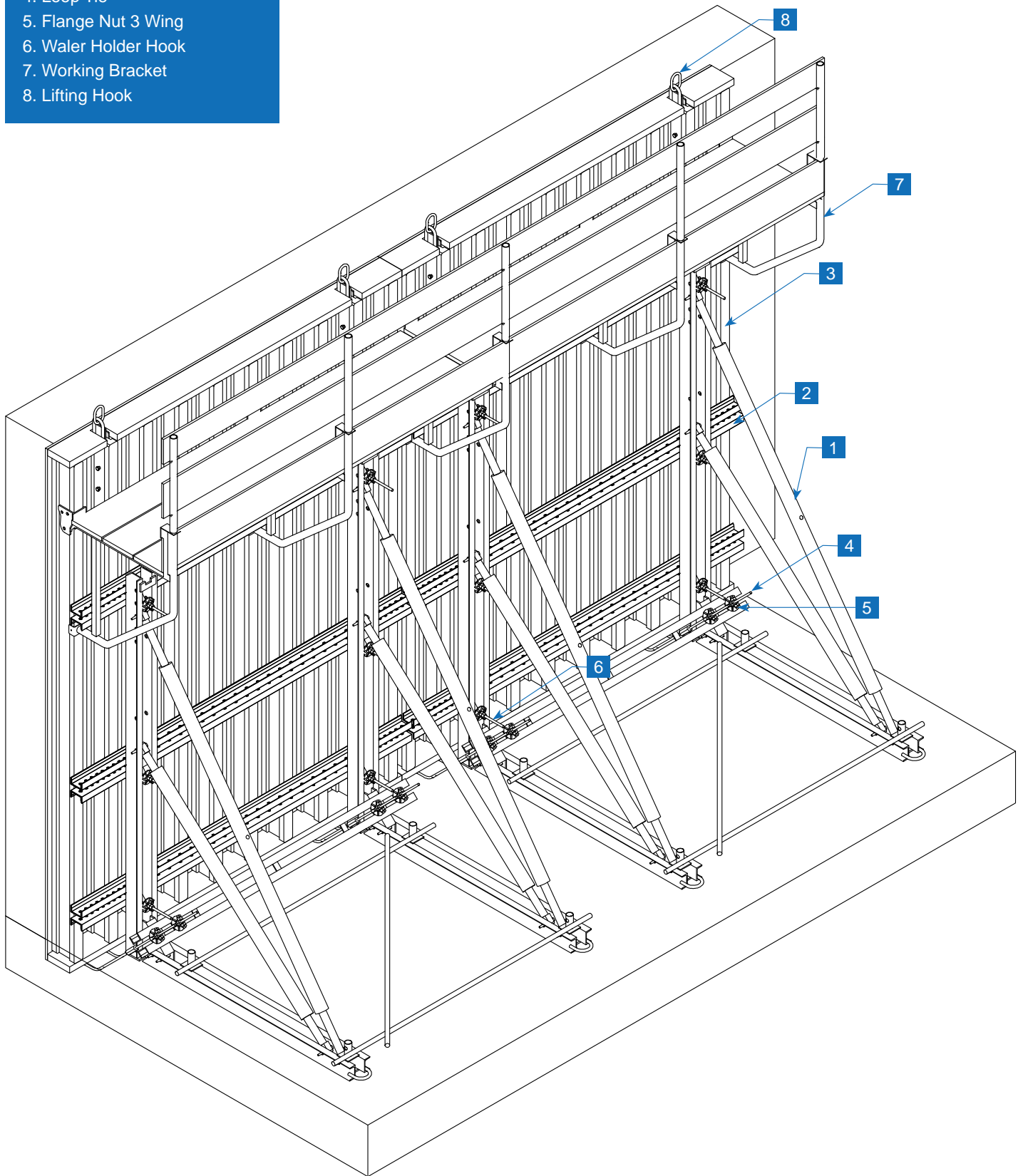

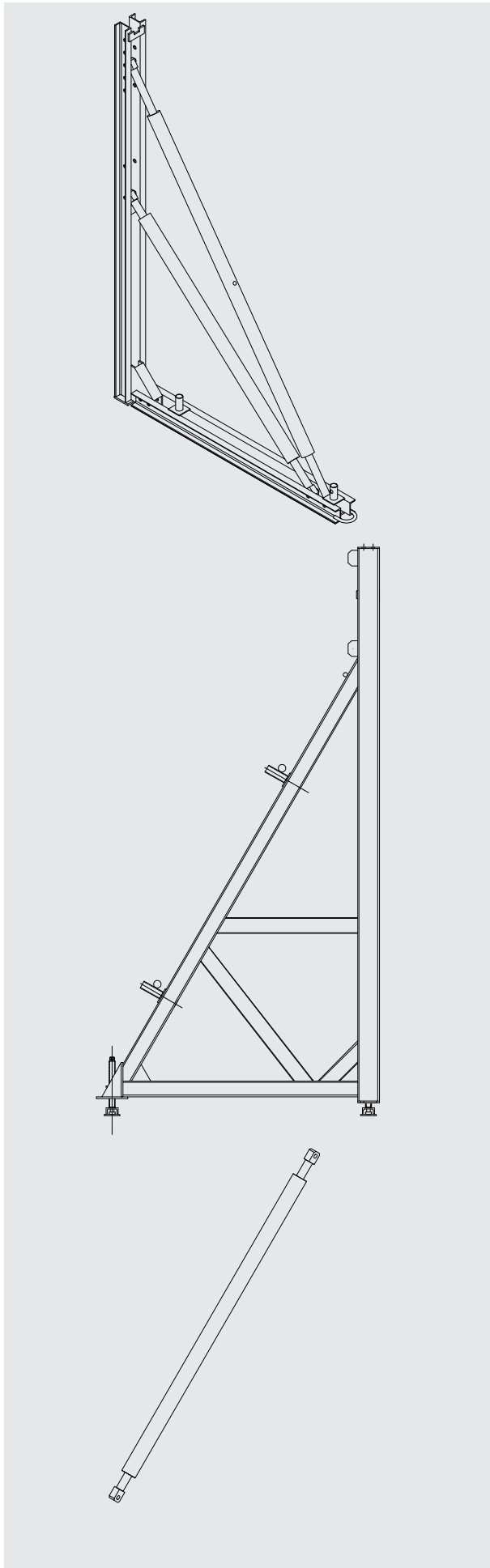

Description	Art. No	Weight
-------------	---------	--------

Supporting Frame UVR	660001	196.10
----------------------	--------	--------

Single Side Support Frame	027510	280.00
---------------------------	--------	--------

Pushpull Strut UVR		
Pushpull Strut UVR 2.00-2.85m	600290	34.50
Pushpull Strut UVR 2.40-3.0m	600291	39.00

Used in connection with the Single Sided Support Frame 500 and the Lower Part 200 for formwork heights of up to 8.60m.

## System Components

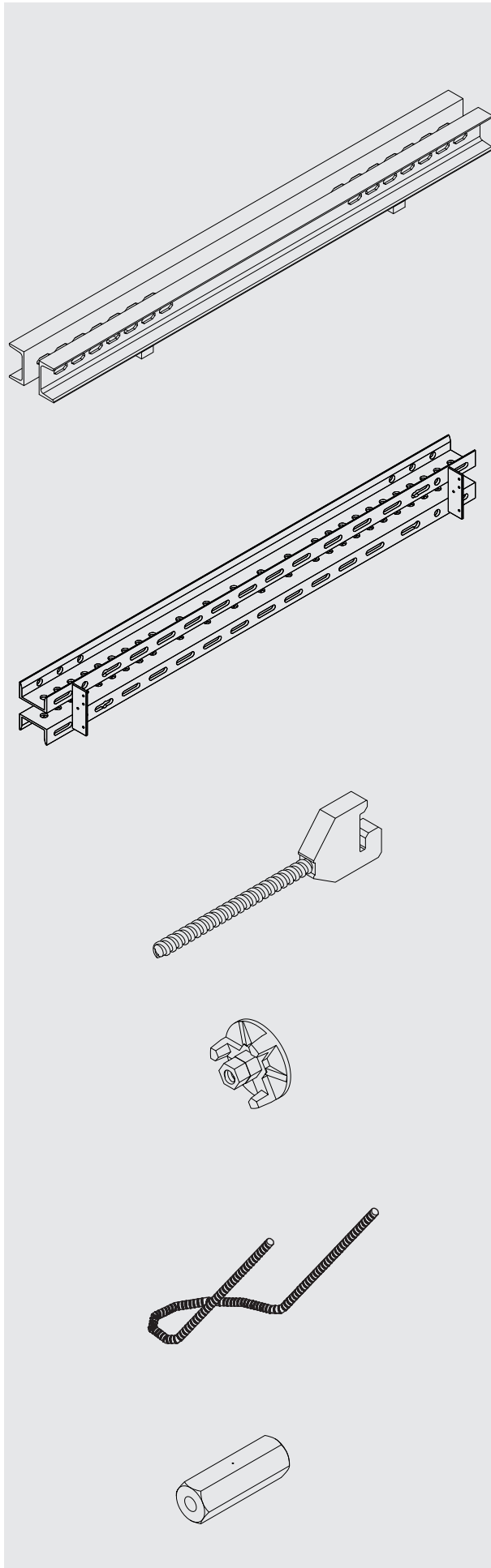

Description	Art. No	Weight
<b>Steel Waler</b>		
Steel Waler 10-0.50m	600256	10.40
Steel Waler 10-0.75m	600257	15.40
Steel Waler 10-1.00m	600258	20.20
Steel Waler 10-1.25m	600259	25.00
Steel Waler 10-1.50m	600260	30.30
Steel Waler 10-2.00m	600261	40.20
Steel Waler 10-2.50m	600262	51.00
Steel Waler 10-3.00m	600263	60.40
Steel Waler 10-3.75m	600264	71.50
Steel Waler 10-5.00m	600265	102.00
Steel Waler 10-6.00m	600266	122.20
<b>Multi Purpose Steel Waler 10-0.50m</b>		
Multi Purpose Steel Waler 10-0.50m	600300	10.20
Multi Purpose Steel Waler 10-0.75m	600301	14.90
Multi Purpose Steel Waler 10-1.00m	600302	19.60
Multi Purpose Steel Waler 10-1.25m	600303	24.70
Multi Purpose Steel Waler 10-1.50m	600304	29.70
Multi Purpose Steel Waler 10-2.00m	600305	38.90
Multi Purpose Steel Waler 10-2.50m	600306	48.70
Multi Purpose Steel Waler 10-3.00m	600307	60.20
Multi Purpose Steel Waler 10-3.75m	600308	71.20
Multi Purpose Steel Waler 10-5.00m	600309	101.60
Multi Purpose Steel Waler 10-6.00m	600310	122.00
<b>Waler Holder Hook U</b>		
600292	600292	1.75
Connects the Formwork to the Single Sided Supporting Frame.		
<b>Flange nut 3 wing 100 V</b>		
600075	600075	0.75
Used for tying and connecting purposes. with a max. permissible load of 90 kN.		
<b>Loop Tie</b>		
600293	600293	1.90
Is cast-in concrete and transfers the Tensile Force in to the Building Structure.		
<b>Hexagonal Coupler Galv.</b>		
600294	600294	0.50
Fastens the cast-in and reusable anchor elements		

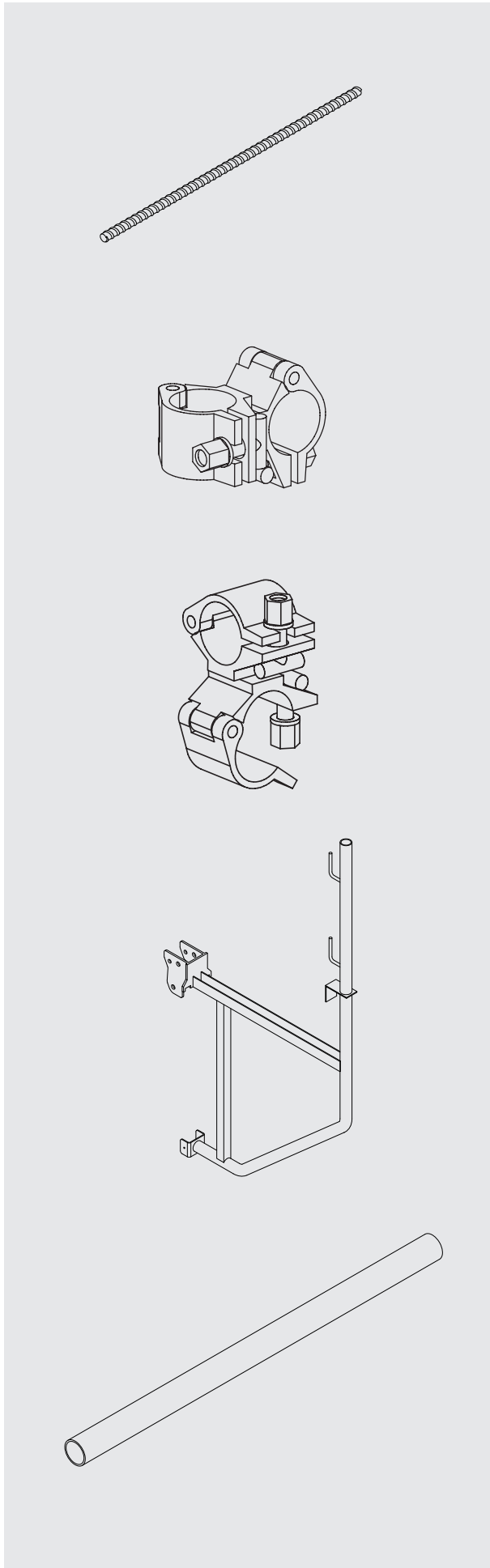

Description	Art. No	Weight
<b>Tie Rod</b>		
Tie Rod 15 mm Dia./D&W 50	600286	1.20
Tie Rod 15 mm Dia./D&W 75	600240	1.50
Tie Rod 15 mm Dia./D&W 100	600241	1.95
Tie Rod 15 mm Dia./D&W 130	600242	2.45
Tie Rod 15 mm Dia./D&W 175	600242	2.45
<b>Rigid Coupler</b>		
	700225	1.30
<b>Swivel Coupler</b>		
	700226	1.30
<b>Working Bracket</b>		
	600277	17.00
Equipped with upper U-profile where wooden beams on top can be fasten by nails. Furthermore, the bracket is built in with handrail post.		
<b>Scaffold Tube</b>		
Scaffold Tube 50 cm	602101	1.90
Scaffold Tube 100 cm	602102	3.80
Scaffold Tube 150 cm	602103	5.70
Scaffold Tube 200 cm	602104	7.60
Scaffold Tube 250 cm	602105	9.50
Scaffold Tube 300 cm	602106	11.40
Scaffold Tube 350 cm	602107	13.30
Scaffold Tube 400 cm	602108	15.20
Scaffold Tube 450 cm	602109	17.10
Scaffold Tube 500 cm	602110	19.00
Scaffold Tube 600 cm	602111	23.00



# Material Test Certificate

## Technical data

### Product

Wooden formwork beams, glued, solid-walled I-beams

### Wood species

Spruce, fir, mixed types available

### Wood moisture

12% ± 3%

### Gluing

Melamine resin-based adhesive, adhesive type I EN 301 approved for gluing of load-bearing wood structural elements.

### Chord

- Visually graded to strength class S10 acc. to DIN 4074
- Finger-jointed, high-grade, solid whitewood, fingerjoints acc. to DIN 68140-1
- Chords are grooved on the side turned away from the core (left side of chord surface)
- Smoothly surfaced and chamfered to approx. 4 mm

### Webs

- 3-ply solid wooden panel for structural and exterior application acc. to EN 13353
- Primarily vertical growth rings in outer and middle layer

### Surface protection

Treatment of entire beam using a water-resistant color stain.





### Support

Due to the 3-ply solid wood webs, HT plus formwork beams can be cut into and supported at any length.

### Packaging

The packages are delivered suitable for the construction site and protected by integrated supporting timber.

## Product overview

Formwork beam	HT 12plus	HT 16plus	HT 20plus	HT 24plus	HT 30plus
					
Weight and dimensions					
Beam height	120 mm	160 mm	200 mm	240 mm	300 mm
Chord height	35 mm	35 mm	40 mm	40 mm	57 mm
Chord width	65 mm	65 mm	80 mm	80 mm	96 mm
Web thickness	26.6 mm	26.6 mm	26.6 mm	26.6 mm	26.6 mm
Web thickness	2.8 kg/m	3.3 kg/m	4.6 kg/m	5.1 kg/m	7.6 kg/m
Calculated values					
EI MOE x moment of inertia	97 kNm²	212 kNm²	486 kNm²	775 kNm²	1,906 kNm²
E <sub>chord</sub> Modulus of elasticity chord (C24)	11,000 N/mm²	11,000 N/mm²	11,000 N/mm²	11,000 N/mm²	11,000 N/mm²
E <sub>web</sub> Modulus of elasticity web (3-ply panel)	6,700 N/mm²	6,700 N/mm²	6,700 N/mm²	6,700 N/mm²	6,700 N/mm²
V <sub>l</sub> Characteristic value of lateral force	15.3 kN	18.4 kN	23.9 kN	28.2 kN	34.5 kN
R <sub>l</sub> Characteristic value of supporting	29.4 kN	36.8 kN	47.8 kN	56.4 kN	69 kN
M <sub>l</sub> Characteristic value of moment	4.4 kNm	5.9 kNm	10.9 kNm	14.1 kNm	26.2 kNm
Quality-monitored production	WPK	WPK	WPK + MPA	WPK	WPK

FPC = Internal factory production control / MPA = External monitoring by Material Testing Institute in Stuttgart

### Carrying capacity values for the construction site

Conversion of characteristic value for permissible measurement value using old measurement concept according to EN 13377 Appendix E

$$X = k_{mod} \times X_k / \gamma$$

X Rated value of material property

X<sub>k</sub> Characteristic value of material property

k<sub>mod</sub> Modification value of wood moisture < 20% is 0.9

γ<sub>l</sub> Partial safety factor for wood and wood materials is 1.3

perm. X = X<sub>k</sub> / γ<sub>l</sub>

perm. X = Permissible value of material property

γ Permissible value of material property

Technical data HT 20plus



Dimensions and tolerances

Dimensions	HT 20plus	Tolerances
Beam height	200 mm	± 2.0 mm
Chord thickness	40 mm	- 1.5%
Chord width	80 mm	- 1.5%
Web thickness	26.6 mm	± 0.5 mm

Product standard

The EN 13377 defines the classification, requirements and test methods for formwork timber beams with building heights of h = 16 cm, h = 20 cm and h = 24 cm. In Germany, the DIN EN 13377 applies in combination with DIN V 20000-2. The HT 20plus is marked with an "Ü" according to the regulations applicable in Germany.

Calculated values

According to EN 13377	Carrying capacity characteristics	
Lateral force	$V_k = 23.9$ kN	perm. Q = 11 kN
Bending moment	$M_k = 10.9$ kNm	perm. M = 5 kNm
Reaction of support	$R_{k,tab} = 47.8$ kN	
MOE x moment of inertia	$EI = 486$ kNm <sup>2</sup>	
Elasticity module of chord (C24)	$E_{C24} = 11,000$ N/mm <sup>2</sup>	
Elasticity module of web (SWP)	$E_{SWP} = 6,700$ N/mm <sup>2</sup>	

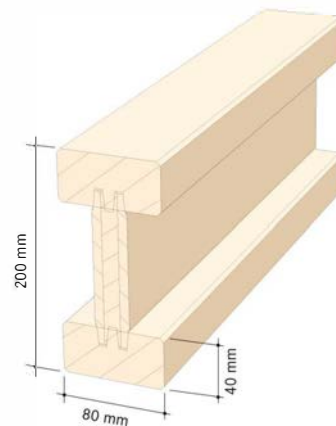

Standard lengths

2.45/2.50/2.65/2.90/3.30/3.60/3.90/4.20/4.50 / 4.90/5.90/max. 10.00 m

Weight

4.6 kg/m

Package units

standard package: 60 pieces, Container package: 100 pieces



## Span table

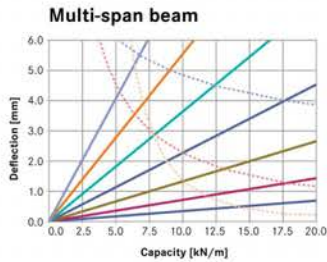
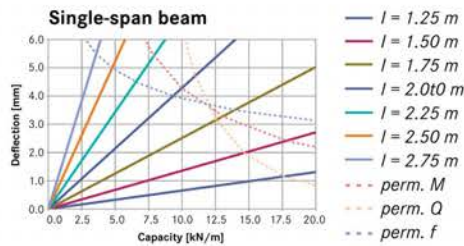

Floor thickness [cm]	Total load [kN/m <sup>2</sup> ]	Table 1: Crossbeams Distance between crossbeams [m]								Table 2: Main beams Selected distance between main beams [m]				
		0.5	0.625	0.675	0.75	1	1.25	1.5	1.75	2	2.25	2.5	3	3.5
		Max. support width of crossbeam = Max. distance between main beams								Max. permissible support width = Distance between supports				
10	4.60	3.64	3.38	3.29	3.18	2.89	2.64	2.41	2.23	2.09	1.97	1.87	1.59	1.37
12	5.12	3.46	3.21	3.13	3.02	2.74	2.50	2.28	2.11	1.98	1.86	1.72	1.43	1.23
14	5.64	3.30	3.07	2.99	2.89	2.62	2.38	2.17	2.01	1.88	1.73	1.56	1.30	1.11
16	6.16	3.18	2.95	2.87	2.77	2.52	2.28	2.08	1.93	1.79	1.59	1.43	1.19	1.02
18	6.68	3.07	2.85	2.77	2.68	2.43	2.19	2.00	1.85	1.65	1.46	1.32	1.10	0.94
20	7.20	2.97	2.76	2.69	2.59	2.36	2.11	1.92	1.75	1.53	1.36	1.22	1.02	0.87
22	7.72	2.88	2.68	2.61	2.52	2.28	2.04	1.86	1.63	1.42	1.27	1.14	0.95	0.81
24	8.24	2.81	2.61	2.54	2.45	2.20	1.97	1.78	1.53	1.33	1.19	1.07	0.89	0.76
26	8.76	2.74	2.54	2.48	2.39	2.14	1.91	1.67	1.44	1.26	1.12	1.00	0.84	0.72
28	9.28	2.68	2.49	2.42	2.34	2.08	1.86	1.58	1.35	1.19	1.05	0.95	0.79	0.68
30	9.80	2.62	2.43	2.37	2.29	2.02	1.80	1.50	1.28	1.12	1.00	0.90	0.75	0.64
35	11.23	2.50	2.32	2.26	2.18	1.89	1.57	1.31	1.12	0.98	0.87	0.78	0.65	0.56
40	12.65	2.39	2.22	2.16	2.05	1.74	1.39	1.16	0.99	0.87	0.77	0.70	0.58	0.50
45	14.08	2.30	2.13	2.05	1.95	1.56	1.25	1.04	0.89	0.78	0.69	0.63	0.52	0.45
50	15.50	2.23	2.03	1.96	1.85	1.42	1.14	0.95	0.81	0.71	0.63	0.57	0.47	0.41
55	16.93	2.16	1.94	1.87	1.73	1.30	1.04	0.87	0.74	0.65	0.58	0.52	0.43	0.37
60	18.35	2.09	1.87	1.78	1.60	1.20	0.96	0.80	0.69	0.60	0.53	0.48	0.40	0.34
65	19.78	2.01	1.78	1.65	1.48	1.11	0.89	0.74	0.64	0.56	0.49	0.45	0.37	0.32
70	21.20	1.94	1.66	1.54	1.38	1.04	0.83	0.69	0.59	0.52	0.46	0.42	0.35	0.30
75	22.50	1.89	1.56	1.45	1.30	0.98	0.78	0.65	0.56	0.49	0.43	0.39	0.33	0.28
80	23.80	1.83	1.48	1.37	1.23	0.92	0.74	0.62	0.53	0.46	0.41	0.37	0.31	0.26
85	25.10	1.75	1.40	1.30	1.17	0.88	0.70	0.58	0.50	0.44	0.39	0.35	0.29	0.25
90	26.40	1.67	1.33	1.23	1.11	0.83	0.67	0.56	0.48	0.42	0.37	0.33	0.28	0.24
95	27.70	1.59	1.27	1.18	1.06	0.79	0.64	0.53	0.45	0.40	0.35	0.32	0.26	0.23
100	29.00	1.52	1.21	1.12	1.01	0.76	0.61	0.51	0.43	0.38	0.34	0.30	0.25	0.22

### Sample calculation

- Required: Distance between main beams and between supports
- Available:  30 cm concrete thickness with total load of 9.80 kN/m<sup>2</sup>
- Selected:  Distance between crossbeams of 0.75 m
- Result:  2.29 m distance between main beams  
 (select next larger distance between main beams, here  2.5 m)  
 0.90 m distance between supports (check carrying capacity of supports)

# Properties



## 3 glued layers in top quality for the highest requirements

**K1 yellowplan** is the concrete formwork panel made by Mayr-Melnhof Holz. The panels are used anywhere where top quality, durability, and a flawless concrete appearance is required. The **K1 yellowplan** is manufactured in Reutte in Austria's Bregenzwald region and is promptly delivered from there to your location, or by request directly to the construction site. The legendary **K1 yellowplan** has been manufactured for over 50 years. The new procedure was recognized as a path breaking achievement from the very beginning. Since the 80s the **K1 yellowplan** has been manufactured on an industrial production line.

Today this 3-ply laminated formwork panel continues to impress with its unique quality and high form stability.

The **K1 yellowplan** formwork panel is made in a jumbo size of 2 x 6 m and thicknesses of 21 and 27 mm and is then cut to smaller standard sizes.

The enclosed, laminated outer and intermediate layers without concealed edge bands and showing primarily vertical growth rings are the foundation for the clean **K1 yellowplan** typical concrete appearance.



# Technical data K1 yellow plan



## Product

3-ply concrete formwork panel with smooth surface and melamine resin coating according to Austrian standard ÖN B 3023 solid wood panels.

## Wood species

Spruce, fir, mixed types permitted

## Wood moisture

12% ± 3%

## Gluing

BFU 100 (AW 100) in accordance with ÖN B 3023

## Weight

21 mm approx. 10.0 kg/m<sup>2</sup>

27 mm approx. 12.5 kg/m<sup>2</sup>

## Features of panel

- Manufactured as a jumbo size panel, small sizes are cut to exact specifications from jumbo formats
- Locked, glued crosswise
- Fully enclosed, laminated outer and intermediate layer, no concealed edge bands
- Outer layers predominantly showing vertical growth rings, no clamps
- Seamlessly glued intermediate layer, ensures that the longitudinal edges do not tear off
- Seamlessly sanded
- Resistant melamine coating
- Water repellent edge seal

## Formats

Standard formats (length x width in cm)

100 x 50

150 x 50

200 x 50/100

250 x 50/100

300 x 50/100

Jumbo formats (length x width in cm)

400 x 50/100/150/200

500 x 50/100/150/200

600 x 50/100/150/200

## Thicknesses

21 and 27 mm

## Surface quality

- Seamlessly sanded surface
- Resistant melamine coating with approx. 130 g/m<sup>2</sup>, each side

## Edge seal

- Water repellent formwork edge finish, yellow
- PU edge seal, red with jumbo- and special sizes with standard formats (except for 100 x 50 cm)

## Packaging

Packages: 50 pieces of 21 mm or 40 pieces of 27 mm thickness

- Delivered suitable for the construction site, protected by integrated supporting timber
- Upon request, the packages will be wrapped in plastic foil
- The package units for jumbo formats are subject to arrangement

## Dimensional tolerances

<b>Thicknesses</b>	21 and 27 mm	± 1 mm
<b>Widths</b>	50 ≤ 200 cm	± 1 mm
<b>Lengths</b>	100 ≤ 250 cm	± 1 mm
	300 ≤ 600 cm	± 2 mm
<b>Longitudinal curvature</b>	100 ≤ 300 cm	± 1 mm
	301 ≤ 600 cm	± 1.5 mm
	Breiten < 50 cm	± 1 ‰

## Design values

<b>Mechanical properties</b>	<b>21 mm</b>	<b>27 mm</b>	<b>Minimal value ÖN B 3023</b>
Minimal value	40 N/mm <sup>2</sup>	35 N/mm <sup>2</sup>	22 N/mm <sup>2</sup>
Modulus of elasticity (mean value)	10,000 N/mm <sup>2</sup>	10,000 N/mm <sup>2</sup>	10,000 N/mm <sup>2</sup>

*The calculated values with a wood moisture of 12%. With heavy moisture penetration up to fiber saturation point, the values for bending strength and flexural modulus of elasticity may be up to 30% lower.*

		Span L [m]							
d = 21 mm		0.40	0.45	0.50	0.55	0.60	0.65	0.70	0.75
Load q [kN/m <sup>2</sup> ]	5 kN/m <sup>2</sup>	0.11	0.17	0.26	0.38	0.54	0.75	1.00	1.32
	10 kN/m <sup>2</sup>	0.21	0.34	0.52	0.77	1.08	1.49	2.01	2.65
	15 kN/m <sup>2</sup>	0.32	0.51	0.78	1.15	1.63	2.24	3.01	3.97
	20 kN/m <sup>2</sup>	0.43	0.69	1.05	1.53	2.17	2.99	4.02	5.30
	25 kN/m <sup>2</sup>	0.54	0.86	1.31	1.91	2.71	3.74	5.02	6.62
	30 kN/m <sup>2</sup>	0.64	1.03	1.57	2.30	3.25	4.48	6.03	7.95
	35 kN/m <sup>2</sup>	0.75	1.20	1.83	2.68	3.80	5.23	7.03	9.27
	40 kN/m <sup>2</sup>	0.86	1.37	2.09	3.06	4.34	5.98	8.04	10.59

d = 21 mm  
 E = 10,000 N/mm<sup>2</sup> of K1 yellowplan d = 21 mm  
 k = 0.646 Deformation factor contingent on number of fields for constant load

Deflection of formwork panel K1 yellowplan d = 21 mm

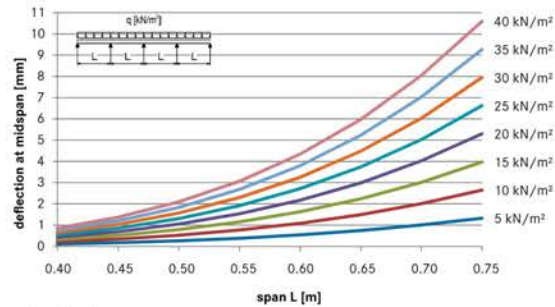

		Span L [m]							
d = 27 mm		0.40	0.45	0.50	0.55	0.60	0.65	0.70	0.75
Load q [kN/m <sup>2</sup> ]	5 kN/m <sup>2</sup>	0.05	0.08	0.12	0.18	0.26	0.35	0.47	0.62
	10 kN/m <sup>2</sup>	0.10	0.16	0.25	0.36	0.51	0.70	0.95	1.25
	15 kN/m <sup>2</sup>	0.15	0.24	0.37	0.54	0.77	1.05	1.42	1.87
	20 kN/m <sup>2</sup>	0.20	0.32	0.49	0.72	1.02	1.41	1.89	2.49
	25 kN/m <sup>2</sup>	0.25	0.40	0.62	0.90	1.28	1.76	2.36	3.12
	30 kN/m <sup>2</sup>	0.30	0.48	0.74	1.08	1.53	2.11	2.84	3.74
	35 kN/m <sup>2</sup>	0.35	0.57	0.86	1.26	1.79	2.46	3.31	4.36
	40 kN/m <sup>2</sup>	0.40	0.65	0.98	1.44	2.04	2.81	3.78	4.98

d = 27 mm  
 E = 10,000 N/mm<sup>2</sup> of K1 yellowplan d = 27 mm  
 k = 0.646 Deformation factor contingent on number of fields for constant load

Deflection of formwork panel K1 yellowplan d = 27 mm

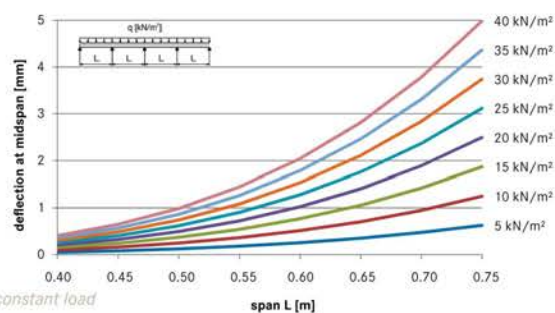

**Product standard and quality definition**

The product standard for 3-ply concrete formwork panels (ÖN B 3023) refers, for purposes of classification and test procedures for factory-owned production control, to the relevant European standards on solid wood panels. In terms of wood quality, the surface reflects the appearance class S for solid wood panels (EN 13017-1 Tab.1). The surface structure and coating is assigned to the smooth GL category according to ÖN B 3023.

**1 Concrete appearance**

Due to the lamella structure of the outer layers, the concrete will reveal a smooth and light wood grain which becomes more visible with the increase of the panels service life. The yellow melamine coating protects the panel and ensures the surface finish. It is classified as lightly absorbent. With time and the number of usages, the absorptive capacity of the panel surface decreases and the concrete face becomes lighter.



**2 Fair-faced concrete**

A variety of experience is available in the use of 3-ply melamine coated concrete formwork panels for fair-faced concrete. Depending on the materials, surface defects in the wood (knots, resin pockets, nail holes, filled knot holes or cracks) will influence the absorptive capacity of the formwork facing and cause dark spots in the concrete when first using panels. Better results for fair-faced concrete are obtained starting with the 2<sup>nd</sup> concrete use when residues on the melamine coating from the formwork facing are removed through alkaline reaction or neutralized by the concrete. The recommendations and guidelines in the cement industry must be followed - e.g. leaflet for fair-faced concrete (version of August 2004) published by DBV and BDZ.

TEST REPORT

EMIRATES WORLD SCAFFOLDING TRADING LLC.

LOAD TEST ON SCAFFOLDING PROPS  
BS 5507 : Part 3 : 1982

Report number	D18 - 287472 - 1	Report date:	03.01.18
Project number	21007		
Project name	Meydan The Fields 1026 Villas Project, Nad Al Sheba.		
Project Location	Nad Al Sheba, Dubai.		
Main Contractor			
Client ref./ request no.	Not Given		
Sample description as identified by client	Heavy Duty Galvanized Steel Prop (20kN - 4m)		
Source / Local supplier	Emirates World Scaffolding Trading LLC.		
Sampled by	Main Contractor		
Date/time sample received	03.01.18 / 1100 Hrs.		
Date tested	03.01.18		
Tested by, name/location	PP, ABS/ DXB		

Result:

Open position - 4 m

Peak load (kN)	Observation
59.9	Buckling of Prop

Remarks: None

Test method variation: None  
This report relates only to the sample tested and shall only be reproduced in full and with the written approval of AHS Laboratories.

Alquinn Lätz  
DHOD - Civil Department, Dubai.

Form # Q16.Rev.00

Page 1 of 1

ABU DHABI, U.A.E., P.O. BOX 31039 TEL: (02) 5542254 FAX: (02) 5547215  
DUBAI, U.A.E., P.O. BOX 16756 TEL: (04) 3472201 FAX: (04) 3472727  
JERBA AL, U.A.E., P.O. BOX 16756 TEL: (04) 3472201 FAX: (04) 3472727  
RAJ AL KHAMAH, P.O. BOX 34087 TEL: (07) 2922038 FAX: (07) 4493390  
KALBA, SARAJAH, U.A.E., P.O. BOX 14153 TEL: (09) 2775542 FAX: (09) 2775542

TEST REPORT

CLIENT: EMIRATES WORLD SCAFFOLDING TRADING LLC.

LOAD TEST ON SCAFFOLDING PROPS  
BS 5507 : Part 3 : 1982

Report number	D15 - 219964-1	Report date:	11.11.15
Project name	Quality Assurance		
Consultant	Not given		
Client ref./ request no.	Not given		
Sample description as identified by client	Galvanized Steel Props (30 kN) 4m		
Source	Emirates World Scaffolding Trading LLC.		
Sampled by	Client		
Date/time sample received	10.11.15/ 1320 Hrs.		
Date tested	11.11.15		
Tested by, name/location	MM/ DXB		

Results:

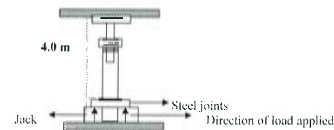

Peak load (kN)	Observation
85.4	Buckling of prop in the middle

Remarks: None

Test method variation: None  
This report relates only to the sample tested and shall only be reproduced in full and with the written approval of AHS Laboratories.

Joseph Mathew  
Head of Physical/Mechanical Dept.  
For Al Hoty-Stanger Laboratories.

Form # Q16.Rev.00

ABU DHABI, U.A.E., P.O. BOX 31039 TEL: (02) 5542254 FAX: (02) 5547215  
DUBAI, U.A.E., P.O. BOX 16756 TEL: (04) 3472201 FAX: (04) 3472727  
JERBA AL, U.A.E., P.O. BOX 16756 TEL: (04) 3472201 FAX: (04) 3472727  
RAJ AL KHAMAH, P.O. BOX 34087 TEL: (07) 2922038 FAX: (07) 4493390  
KALBA, SARAJAH, U.A.E., P.O. BOX 14153 TEL: (09) 2775542 FAX: (09) 2775542



TEST REPORT

EMIRATES WORLD SCAFFOLDING TRADING LLC.

LOAD TEST ON SCAFFOLDING PROPS  
BS 5507 : Part 3 : 1982

Report number	D18 - 288647 - 1	Report date:	15.01.18
Project number	Not given		
Project name	Quality Assurance		
Client ref./ request no.	Not Given		
Sample description as identified by client	Heavy Duty Galvanized Steel Prop (20kN - 3.50m)		
Source	Italy		
Local Supplier	Emirates World Scaffolding Trading LLC.		
Sampled by	Client		
Date/time sample received	15.01.18 / 0900 Hrs.		
Date tested	15.01.18		
Tested by, name/location	PP, ABS/ DXB		

Result:

Open position - 3.5 m

Peak load (kN)	Observation
59.8	Buckling of Prop

Remarks: None

Test method variation: None  
This report relates only to the sample tested and shall only be reproduced in full and with the written approval of AHS Laboratories.

Alquinn Lätz  
DHOD - Civil Department, Dubai.

Form # Q16.Rev.00

Page 1 of 1

ABU DHABI, U.A.E., P.O. BOX 31039 TEL: (02) 5542254 FAX: (02) 5547215  
DUBAI, U.A.E., P.O. BOX 16756 TEL: (04) 3472201 FAX: (04) 3472727  
JERBA AL, U.A.E., P.O. BOX 16756 TEL: (04) 3472201 FAX: (04) 3472727  
RAJ AL KHAMAH, P.O. BOX 34087 TEL: (07) 2922038 FAX: (07) 4493390  
KALBA, SARAJAH, U.A.E., P.O. BOX 14153 TEL: (09) 2775542 FAX: (09) 2775542

FUGRO MIDDLE EAST

geotechnical, materials engineers and surveyors



LOAD TEST ON PROPS - REPORT

Information provided to the Laboratory

Page 1 of 1

Contractor	: NIP	Report No.	: 154717
Client	: Emirates World Scaffolding Trading LLC	Report Date	: 20/01/2008
Consultant	: NIP		
Project	: NIP		

Sample description	: Steel Props 400
Source	: NIP
Location	: NIP
Sampled by	: NIP
Sample brought in by	: Client

Note: NIP indicates information not provided to Lab.

Laboratory Information

Date sample received	: 09/01/2008	FME Project Ref No.	: PE/0011/08/01
Date test started	: 17/01/2008	FME Request No.	: 0045
Date test completed	: 17/01/2008	FME Sample No.	: 08-00286
Test method	: In House (see below)	Tested by	: RID/INJL
Test method variation	: Nil		

Note: N/A indicates information not applicable.

Result

FME Sample Identification	08-00286/1	08-00286/2	08-00286/3	08-00286/4
Supplier	NIP	NIP	NIP	NIP
<b>Section - 1 (Inner Tube)</b>				
Outer diameter (mm)	63.3	63.3	63.3	63.3
Wall thickness (mm)	3.0	3.0	3.0	3.0
Length (mm)	2230	2230	2230	2230
Number of holes	23	23	23	23
Average diameter (mm)	16.4	16.4	16.4	16.4
<b>Section - 2 (Outer Tube)</b>				
Outer diameter (mm)	76.4	76.4	76.4	76.4
Wall thickness (mm)	3.0	3.0	3.0	3.2
Length (mm)	2120	2115	2110	2110
Erected Pin diameter (mm)	16.2	16.2	16.2	16.2
Test length (m)	4.0	4.0	4.0	4.0
Maximum Test Load (Ton), Axial	5.2	4.9	5.7	4.4
Observation	Joint Bent	Joint Bent	Pin Bent	Joint Bent

Test Procedure: The props comprising the two individual slotted sections and retaining pin were erected to a length of 4.0m and placed horizontally in a steel H beam reaction frame. An axial load was applied via a hydraulic cylinder until failure of the props or its individual components were observed.

Note:

The above test results, relate only to the items tested. Fugro does not certify the safe load carrying capacity of the product, and does not purport to address all of the safety concerns, if any, associated with its use. It is the responsibility of the end user to establish appropriate site safety practices.



Authorised by: Laboratory Manager

This report is computer generated and does not require signature.

Results relate only to the item tested. This report shall not be reproduced except in full, without the written approval of the laboratory.

فوجرو الشرق الأوسط  
مهندسين ومختبرات جيوتقنية  
DUBAI: P.O. Box 2863, Tel: +971 4 3474000 Fax: +971 4 3474008 E-mail: fme\_usa@fugro.com  
ABU DHABI: P.O. Box 4447, Tel: +971 2 5542891 Fax: +971 2 5542098 E-mail: fme\_abu@fugro.com



**Laboratory Load Testing of Support Tower System (T-15)  
as per  
BS EN 12813**

<b>Client:</b> Emirates World Scaffolding Trading (LLC)	<b>Date:</b> 26 November 2012
<b>Project:</b> System Development	<b>AFE Job No.:</b> PD101199
<b>Report no.:</b> SR 0241C	<b>Total no of Pages:</b> 8

### 1 Introduction

This report describes the laboratory load test performed on a support tower system by Al Futtaim Exova (AFE) - Façade Testing & Advisory Services in Dubai.

The test was carried out on 19 November 2012.

The test was supervised by:

Vishal Vilaschandran - AFE

This report relates only to the actual sample tested and described herein.

### 2 Sample Description

The test sample comprised of triangulated load bearing tower, 1000mm x 1000mm x 5500mm high. The head jack and the base jack heights were set 200mm and 250 mm respectively.

See photo 1 in Appendix A for the view of the sample. See Appendix B for the sample drawing.

### 3 Purpose of Testing

The tests were to determine the load bearing capacity of a support tower system.

### 4 References

- BSEN 12813-04
- AFE method statement DMF1590/MSrev0

### 5 Test Arrangement

The test arrangement included equipments for applying and measuring the loads and to record the deformation.

Steel beams were used as primary load spread beams and the loading beam.

The tower sample was assembled on test location as designated by AFE. The primary load spreading steel beams were placed across the pairs of fork-heads parallel to its vertical plane. The beams were positioned centrally over the plates of the fork-heads. The loading beam was positioned at right angles between the primary beams. The primary beam and the loading beam were connected together to restrict any relative movement in plan. The vertical load point was adjusted so that its centroid is vertically in line with the centroid of the top of the tower.

The displacement gauges positions are shown in Figure 2. Please see Table 1 for the methodology of the displacement gauge positioning.

See Figure 1 & Photo 2 in Appendix A for the test arrangement.

**Figure 1 Schematic of Test Arrangement**

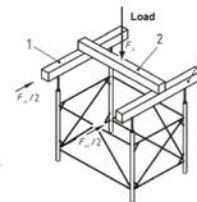

- 1. Primary beams
- 2. Loading beam

**Figure 2 Displacement gauge locations**

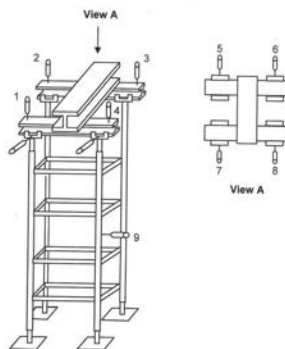

**Table 1 Methodology of Displacement Gauges Placement (See Figure 2)**

Gauge location number	Location
1	On the primary beam at the line of upright (vertically)
2	On the primary beam at the line of upright (vertically)
3	On the primary beam at the line of upright (vertically)
4	On the primary beam at the line of upright (vertically)
5	At the fork head (horizontally)
6	At the fork head (horizontally)
7	At the fork head (horizontally)
8	At the fork head (horizontally)
9	At the frame (horizontally)

### 6 Test Procedure

The masses of the primary and the loading beams were recorded to adjust the loading to give the actual failure load.

A preliminary load was to eliminate any secondary effects that may be caused by imperfections such as slackness at joints or a lack of local fitness at supports. A preliminary load of 10kN (5% of the maximum test load of 200kN), applied vertically. The position of the tower after this load application was taken as reference point of all further measurements of deformation. For this purpose, all the deflection gauges were set to zero upon removing the initial load.

The test loads were gradually applied in steps of 20kN until the maximum required load of 200kN is reached.

The load was further gradually increased until 299kN (maximum capacity of the test equipment).

Load at each increment was sustained until all the movement ceases and the displacement recorded. The sample was visually inspected for any deformation at each load steps and at the end of the load applications.

The following data were recorded at each stage:

- the vertical load applied to the loading beam at each step
- the vertical displacement of the load point relative to the base plates
- the horizontal displacement of the fork-heads relative to the base plates
- the horizontal displacement of one of the uprights

7 Test Results/Observations

Refer to Figure 2 for gauge locations.

Load (kN)	Displacement of gages ... (mm)								
	1	2	3	4	5	6	7	8	9
20	-0.4	-0.4	-0.3	-0.5	0.4	-0.1	-0.4	0.2	0.0
40	-0.8	-0.7	-0.5	-0.9	0.7	-0.1	-0.7	0.3	0.2
60	-1.2	-1.1	-0.9	-1.4	1.1	-0.3	-1.0	0.5	0.0
80	-1.7	-1.4	-1.3	-1.9	1.3	-0.5	-1.2	0.8	-0.2
100	-2.1	-1.8	-1.6	-2.3	1.6	-0.6	-1.3	1.0	0.0
120	-2.2	-1.8	-1.6	-2.3	1.6	-0.6	-1.3	1.0	-0.2
140	-2.6	-2.1	-1.99	-2.7	1.7	-0.7	-1.4	1.2	-0.3
160	-3.0	-2.5	-2.3	-3.1	2.0	-0.8	-1.5	1.4	-0.4
180	-3.5	-2.8	-2.6	-3.6	2.3	-0.9	-1.5	1.6	-0.4
200	-3.9	-3.1	-3.0	-4.0	2.3	-1.0	-1.5	1.7	-0.5
225	-4.3	-3.5	-3.3	-4.6	2.5	-0.9	-1.5	1.7	-0.3
251	-4.8	-3.8	-3.6	-5.2	2.6	-0.8	-1.4	1.7	-0.3
275	-5.7	-4.5	-4.2	-6.2	2.7	-0.6	-0.8	1.7	-0.2
299	-6.2	-4.8	-4.6	-6.8	3.0	-0.6	-0.5	1.6	-0.4

-ve sign : gauge needle extending, +ve sign: gauge needle shortening

\*The loads shown are inclusive of total mass of the loading beam and primary beams = 1.3 kN. During or after the application of the above loads, no damage to the sample was observed.

APPENDIX A Photographs

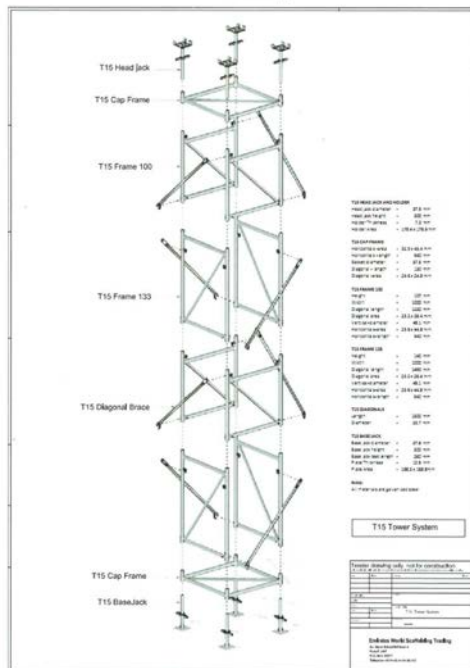

Photo 1 View of the sample



Photo 2 Load test arrangement

APPENDIX B Drawing



A black and white photograph of engineering design tools and blueprints. In the foreground, a pencil lies diagonally across the bottom. To the right, a calculator is positioned over a blueprint. A ruler is visible in the upper right. A compass is in the upper left. The background is filled with technical drawings, including a large blueprint with the text 'WYNIESIENIE NR 1' and 'Ark. 3'. The text 'Engineering Design' is overlaid in the center in a white, bold, sans-serif font.

# Engineering Design

**LOWER ROOF SLAB FORMWORK DETAILS - SYSTEM T-15 TOWER**  
FORMWORK AREA = 174 Sqm

ALL TIMBER BOXOUT/PACKING BY SITE

Formwork to be considered to be restrained in all directions at soffit level. Customer to check and confirm this consideration.

ALWAYS USE ADEQUATE RELEASE AGENT BEFORE SHUTTERING AND CLEAN AFTER DE-SHUTTERING THE FORMWORK

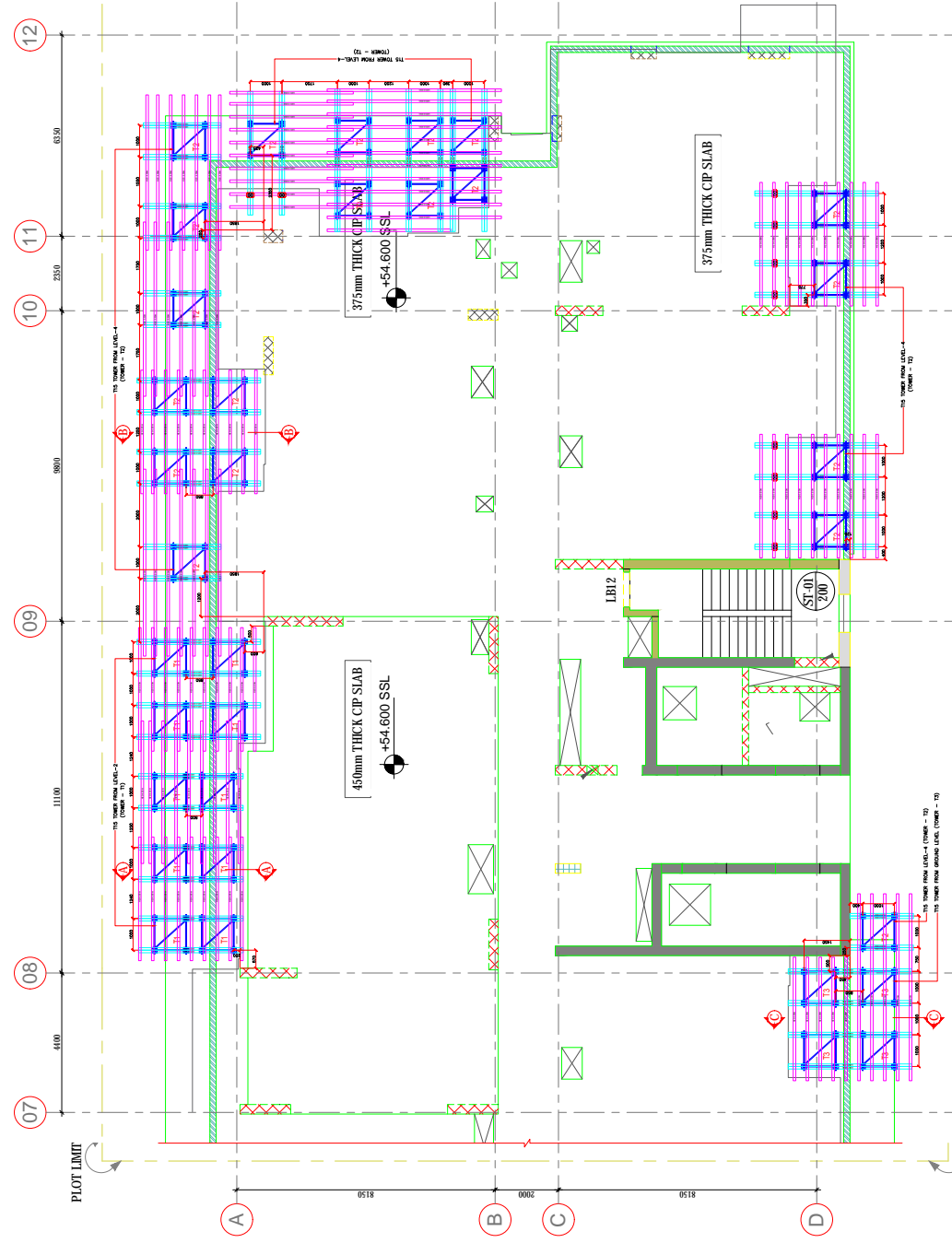

**LOWER ROOF FLOOR SLAB FORMWORK PLAN - SYSTEM T-15 TOWER**  
Scale: 1:75

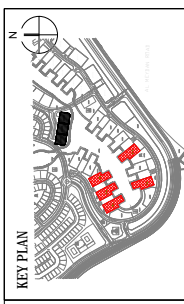

General Notes:

NO.	DESCRIPTION	DATE	APPROVED
01	ISSUE FOR PERMIT	15-04-2022	JH1

**Client:**  
MOHAMMED BIN RASHID AL MAKTUUM CITY  
P.O. Box 36277  
Dubai, UAE  
Tel: +971 4 388 67 196  
Fax: +971 4 388 67 197  
www.mrcity.com

**Principal Consultant:**  
**Q37**  
Q37 CONSULTING LLC  
P.O. Box 5415, Dubai, UAE  
Tel: +971 4 388 67 196  
Fax: +971 4 388 67 197  
www.q37.com

**Main Contractor:**  
**Transemirates CONTRACTING**  
P.O. Box 36277  
Dubai, UAE  
Tel: +971 4 388 67 196  
Fax: +971 4 388 67 197  
www.transemirates.com

**Subcontractor:**  
**Emirates World Trading**  
P.O. Box 36277  
Dubai, UAE  
Tel: +971 4 388 67 196  
Fax: +971 4 388 67 197  
www.emiratesworldtrading.com

**Project Name:**  
MOHAMMED BIN RASHID AL MAKTUUM CITY  
DISTRICT ONE PHASE 3A.1

**Project Description:**  
RESIDENTIAL DEVELOPMENT  
5-BUILDINGS - TEC-122&123  
PLOT 3374843, 48, 51, 50, 45, BUILDING  
(3# B-G-R-B-G-14-R&B-G-20)

**Drawing Title:**  
Building (G+14), Plot - 850  
Lower Roof Level  
Slab Formwork

Scale	Drawn	Checked	Approved	Size
1:75	MF	PVT	JH1	A1

**Drawing Number:**  
DT-PBA-8B4-RES-TEC-AE7-DRG-ST-G-14-RW-001

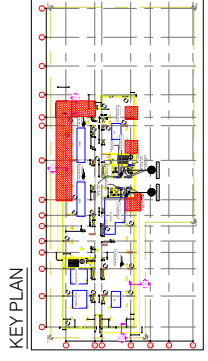

**LOWER ROOF SLAB FORMWORK DETAILS - SYSTEM T-15 TOWER**  
SCALE : 1:75 FORMWORK AREA = 174 Sqm

Formwork is considered to be restrained in all directions at all four ends. Customer to check and confirm this consideration.

ALL TIMBER BOX-OUT / PACKING BY SITE

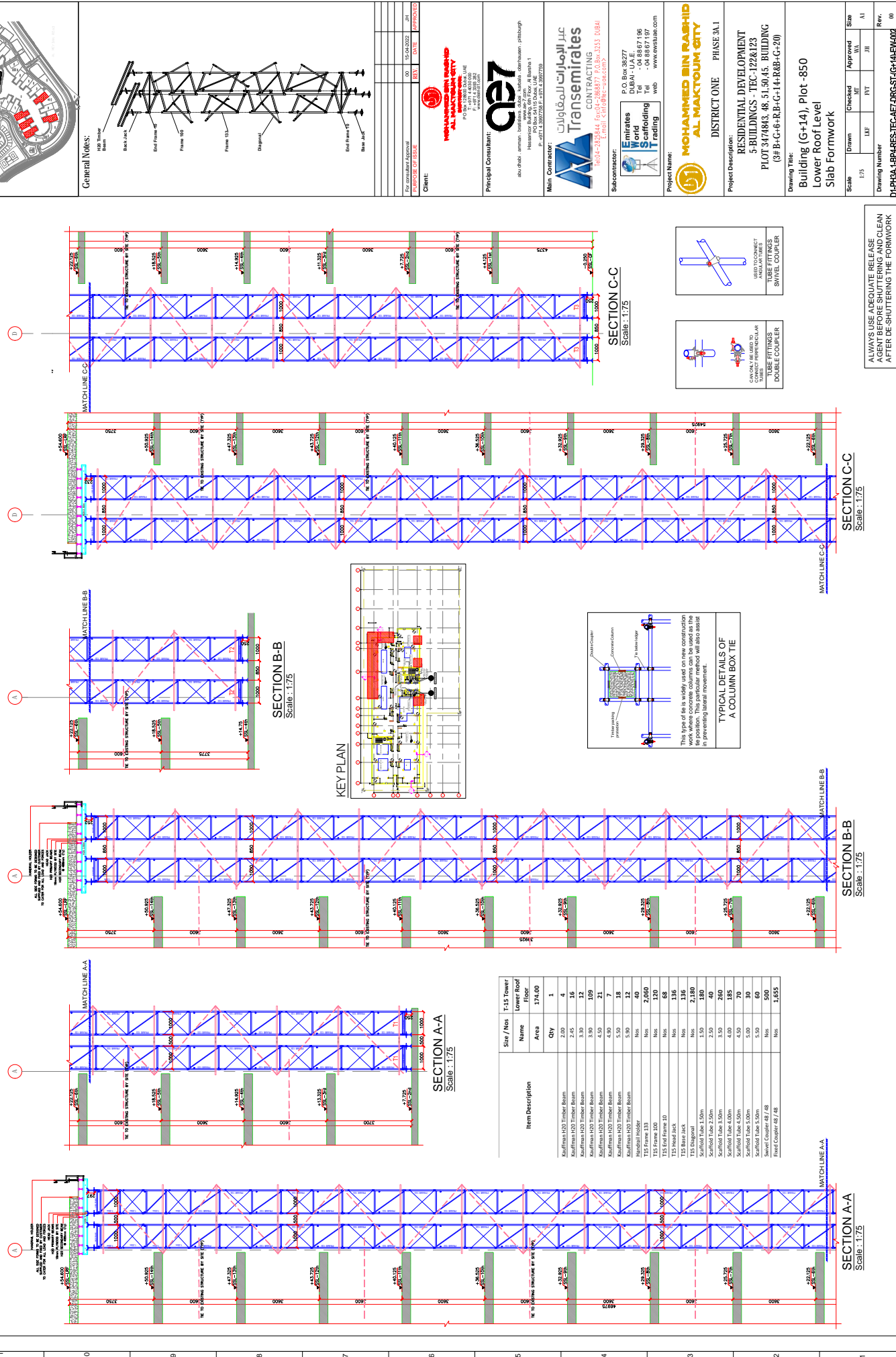

Item Description	Size / Nos	T-15 Tower Lower Roof Floor
Kauffman 1200 Timber Beam	2.00	4
Kauffman 1200 Timber Beam	7.45	16
Kauffman 1200 Timber Beam	3.30	12
Kauffman 1200 Timber Beam	3.90	109
Kauffman 1200 Timber Beam	4.50	21
Kauffman 1200 Timber Beam	5.50	18
Kauffman 1200 Timber Beam	5.90	12
Handrail Holder	Nos	2,050
T15 Frame 135	Nos	120
T15 Frame 100	Nos	68
T15 Hand Jack	Nos	136
T15 Hand Jack	Nos	136
T15 D-Beam	Nos	2,180
Scaffold Tube 150m	1.50	180
Scaffold Tube 30m	2.50	40
Scaffold Tube 30m	3.50	260
Scaffold Tube 40m	4.00	185
Scaffold Tube 150m	4.50	70
Scaffold Tube 150m	5.00	30
Scaffold Tube 150m	5.50	20
Scarf Coupler 48 / 48	Nos	500
Fixed Coupler 48 / 48	Nos	1,655

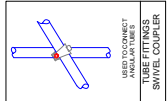
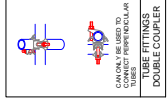
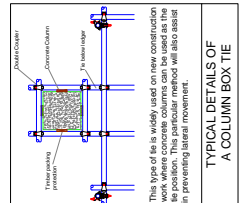

ALWAYS USE ADEQUATE RELEASE AGENT BEFORE SHUTTERING AND CLEAN AFTER DE-SHUTTERING THE FORMWORK

All rights reserved. No part of this drawing may be reproduced or transmitted in any form, by any means, without written permission of the copyright holder. 06/27

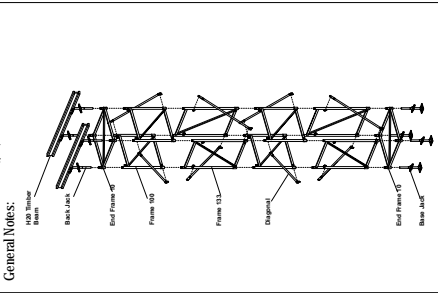
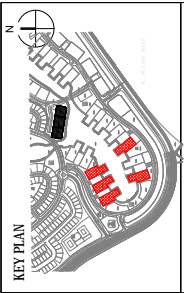

NO.	REVISION / APPROVAL	DATE	BY	CHKD.	APPD.
01	ISSUED FOR PERMIT	15/03/2022	MM	MM	MM
02	ISSUED FOR PERMIT	15/03/2022	MM	MM	MM

**Principal Consultant:**  
AL MAKTUUM CITY  
P.O. Box 12000, Dubai, UAE  
P: +971 4 367 1302  
F: +971 4 367 1302

**Principal Consultant:**  
DUBAI - UAE 5667 196  
DUBAI - UAE 5667 197  
DUBAI - UAE 5667 197  
www.emsultae.com

**Main Contractor:**  
Transmirates  
CONTRACTING  
P.O. Box 38277  
DUBAI - UAE 5667 196  
DUBAI - UAE 5667 197  
DUBAI - UAE 5667 197  
www.emsultae.com

**Subcontractor:**  
EMirates  
World  
Scaffolding  
IT trading  
P.O. Box 38277  
DUBAI - UAE 5667 196  
DUBAI - UAE 5667 197  
DUBAI - UAE 5667 197  
www.emsultae.com

**Project Name:**  
MOHAMMED BIN RASHID  
AL MAKTUUM CITY

**District One:**  
PHASE 3A.1

**Project Description:**  
RESIDENTIAL DEVELOPMENT  
5-BUILDINGS - TEC-122&123  
PLOT 3/47&43, 48, 51, 50, 45, BUILDING  
(3P-B-G-6-R-P-C-14-R&B-G-20)

**Drawing Title:**  
Building (G+14)/ Plot -850  
Lower Roof Level  
Slab Formwork

Scale	1:75	Drawn	Checked	Approved	Size
		MM	MM	JH	A1

**Drawing Number:**  
D1-PH3A.1-BP4-RES-TEC-AE7-DWG-ST-(G+14)-EW-002

**Rev.:**  
00



ALL TIMBER BOX-OUT / PACKING BY SITE

### THIRD FLOOR SLAB FORMWORK PLAN, SECTIONS AND DETAILS - SYSTEM SLABFLEX

SCALE : 1:150, 1:25 FORMWORK AREA = 1623.00 Sqm

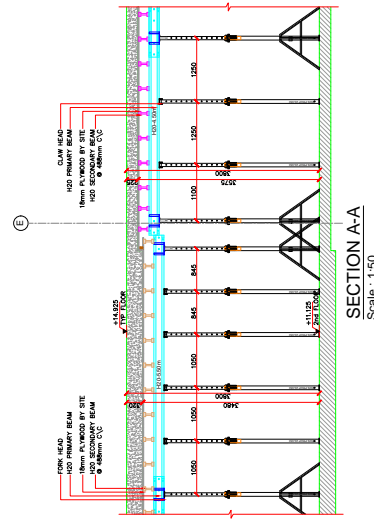
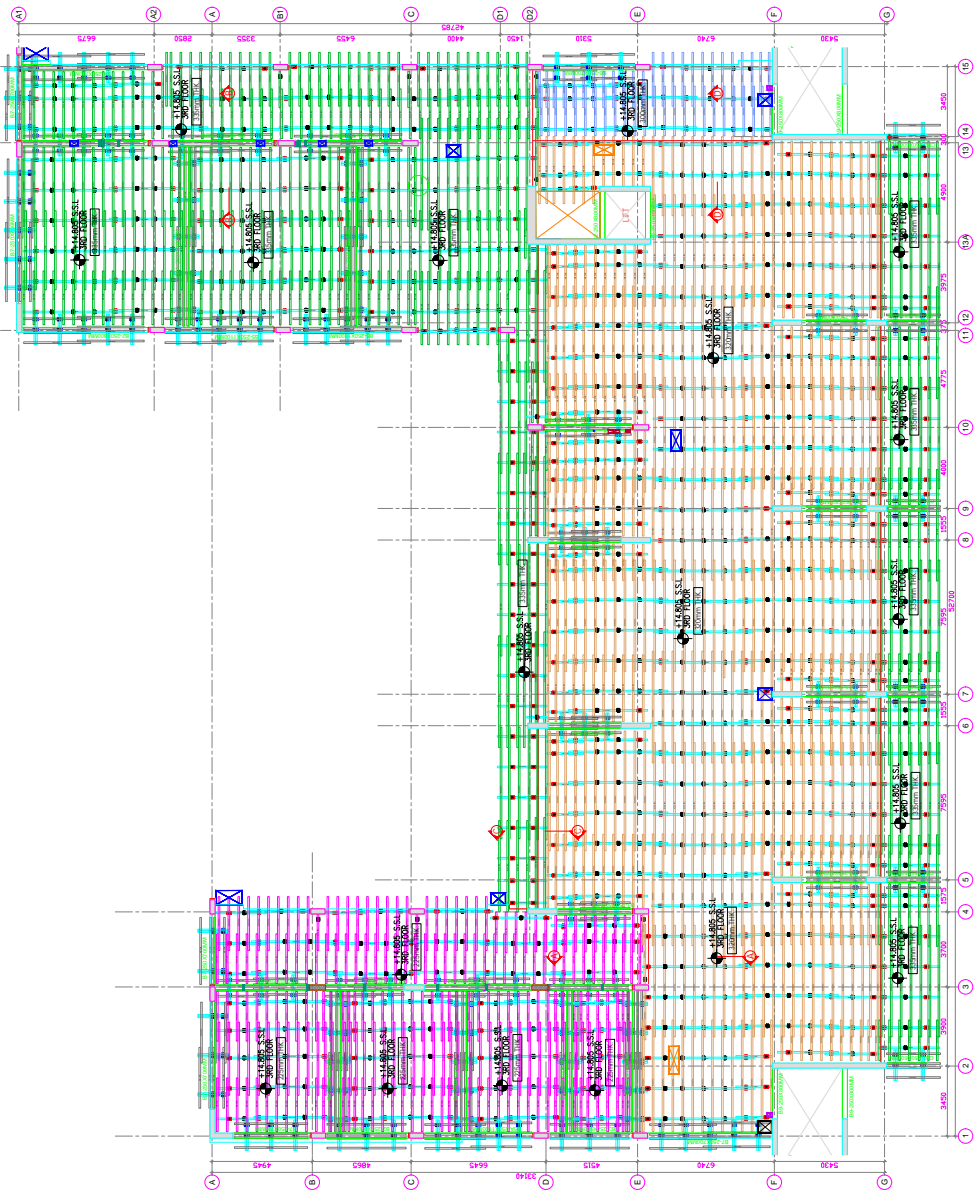

SECTION A-A  
Scale : 1:50

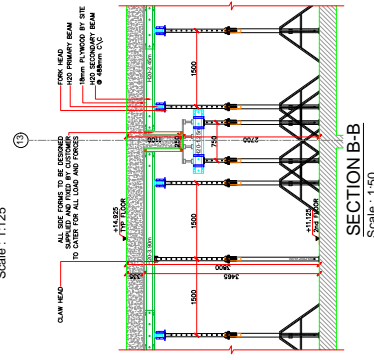

SECTION B-B  
Scale : 1:50

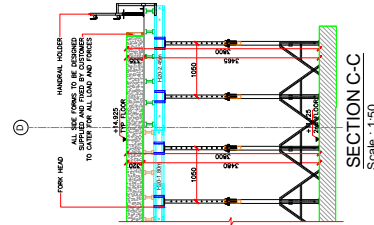

SECTION C-C  
Scale : 1:50

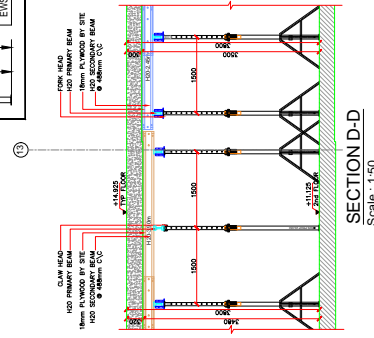

SECTION D-D  
Scale : 1:50

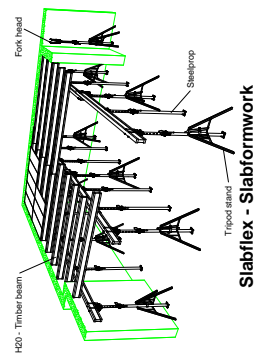

Slabflex - Slabformwork

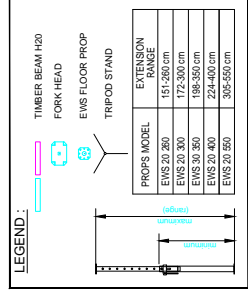

**NOTE:**  
Slab = 250 mm  
Max. distance between main beam = 1500 mm  
Max. distance between secondary beam = 400 mm

**NOTE:**  
Slab = 200 / 305 mm  
Max. distance between main beam = 1500 mm  
Max. distance between secondary beam = 400 mm

Proposed EWS FLOOR PROPS, MODEL NO. 01 (01-1871) - Al Merkah, Dubai, UAE

Item Description	Qty	Third Floor Formwork Area
H100 Timber Beams	1.00	1623.00
H100 Tripod Stands	2.00	1623.00
Fork Heads	1.00	1623.00
Bleed Props	1.00	1623.00
Secondary Beams	1.00	1623.00
Primary Beams	1.00	1623.00
...	...	...

**DRAWING REFERENCE:**

NO.	ISSUE NO.	DESCRIPTION	REV.	DATE

**REVISIONS:**

NO.	REVISION	DATE	BY	CHECKED

**CLIENT:** Dalmon Investments, Owned by The Persson Company LLC

**CONSULTANT:** PNC STRUCTURES

**PROJECT:** HARTLAND INTERNATIONAL SCHOOL

**LOCATION:** AL MERKAH, DUBAI, UNITED ARAB EMIRATES

**MAIN CONTRACTOR:** MERAH INTEGRATED CONTRACTING LLC

**SUB CONTRACTOR:** Emirates Steel Reinforcing

**DRAWING TITLE:** THIRD FLOOR SLAB FORMWORK PLAN, SECTIONS AND DETAILS SYSTEM SLABFLEX





# Formwork Site Photos

# T15 Tower

Over 17m high Slab is support by T15 Tower



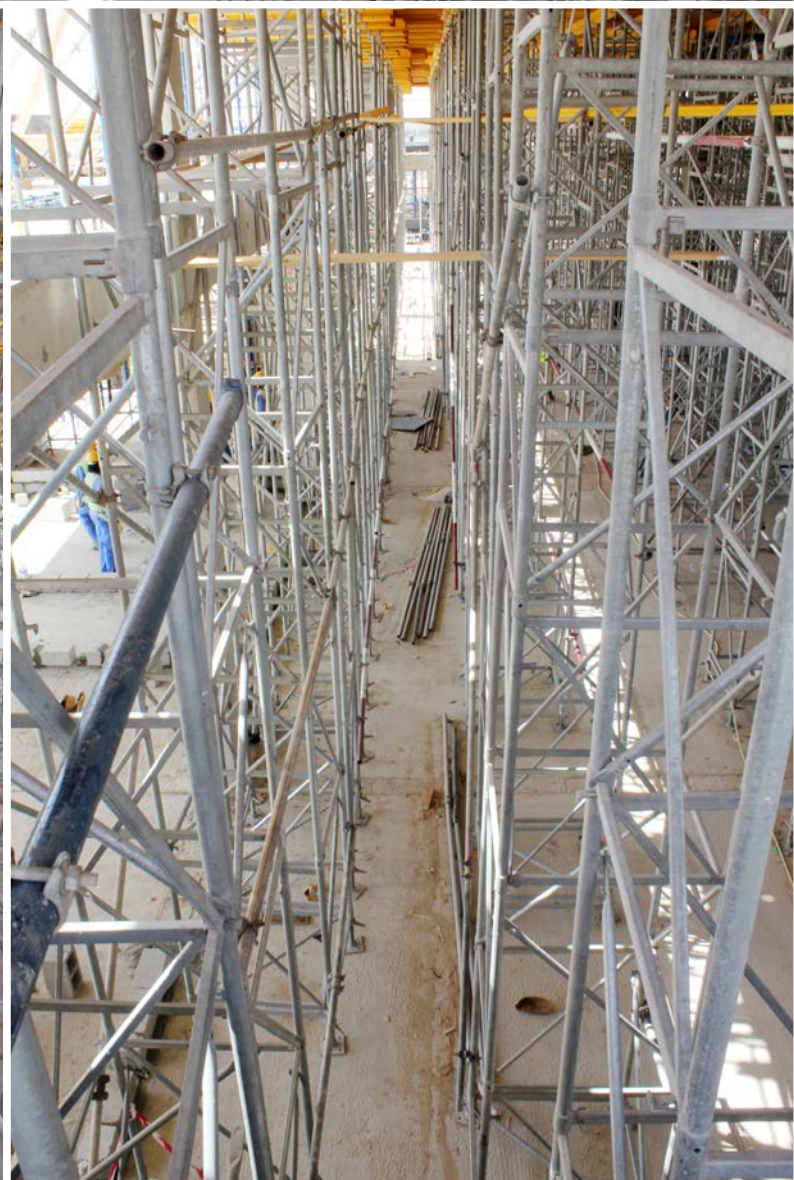



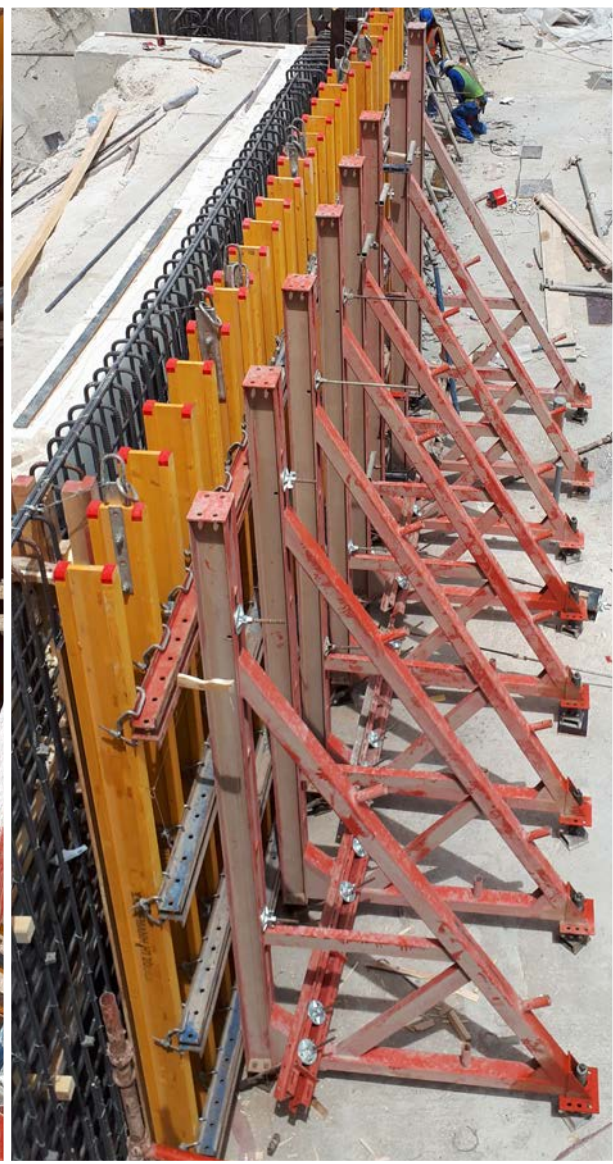











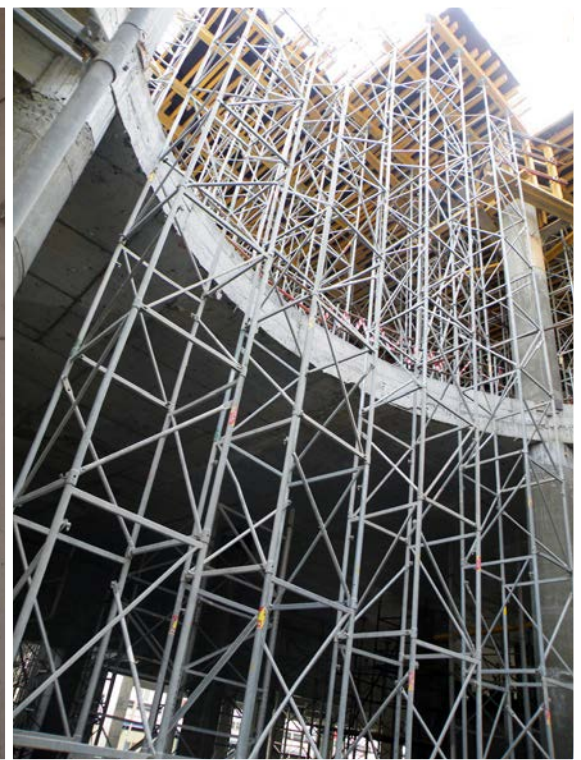



Using Slab flex @ maximum height (5.50m )

Erecting H20 panel for core-wall formwork setting-out





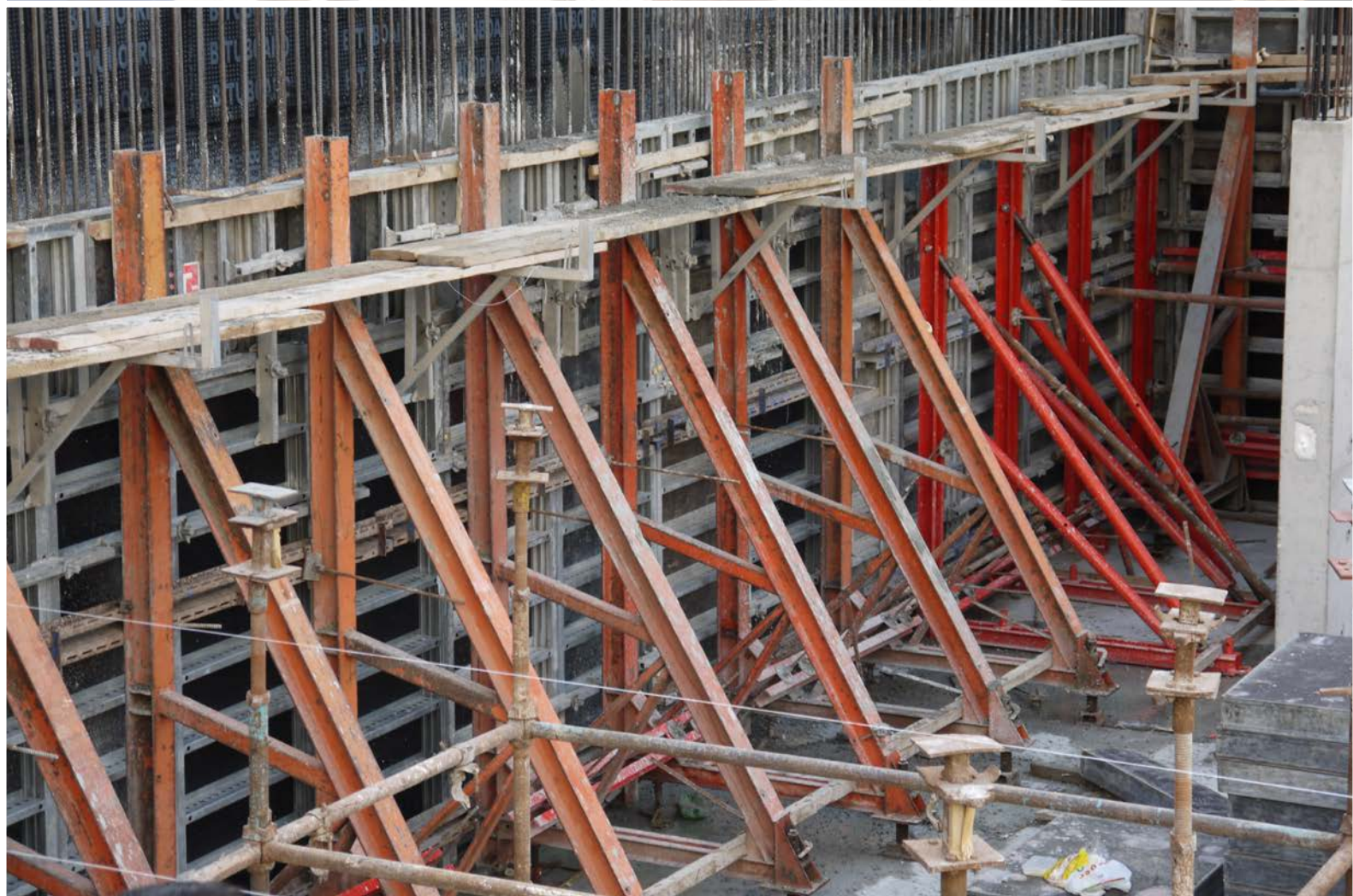



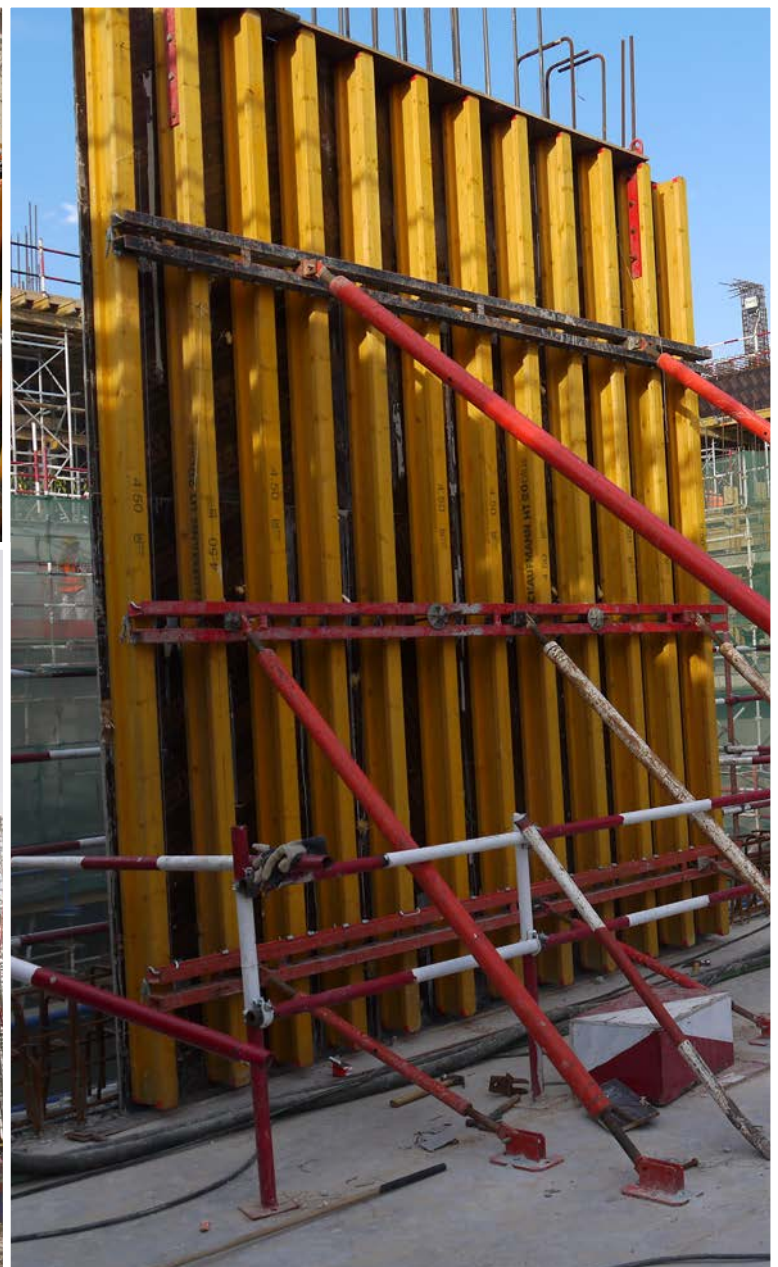



Formwork Erected



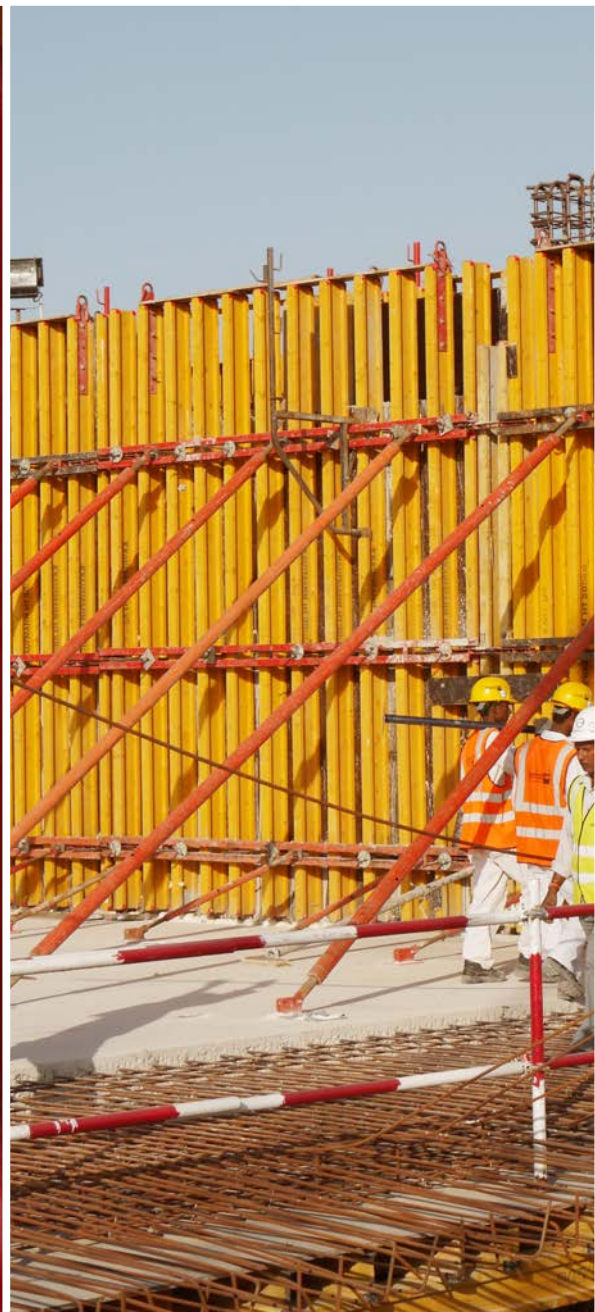



# COMPLETED PROJECTS

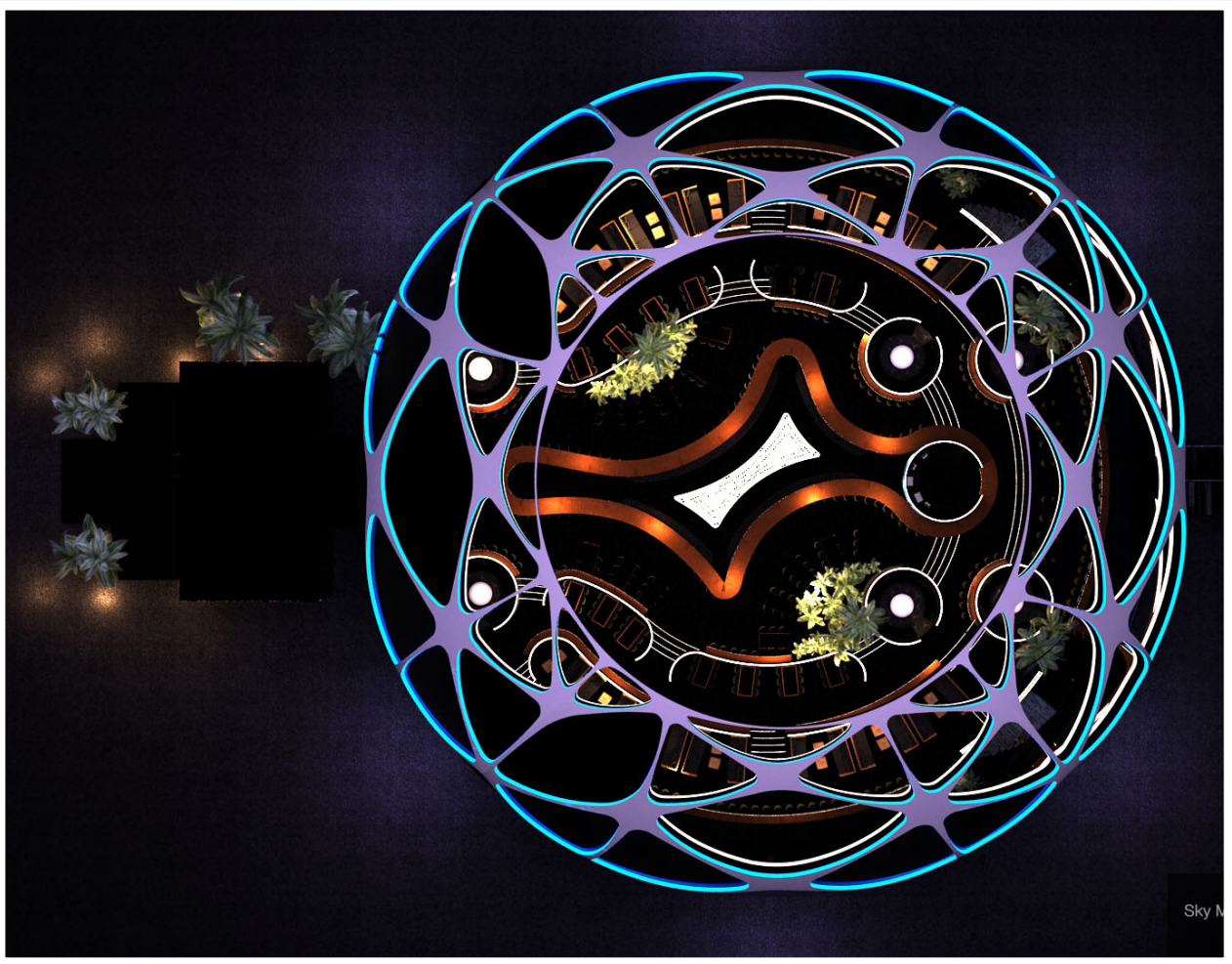

SKY 2.0 @ DESIGN DISTRICT 3 DUBAI

BINGHATTI EAST & WEST B+G+6+ROOF @ DUBAI LAND



PARKING BLDG @ GARHOUD





**KHALIDIA HOTEL @ Muraqqabat**

**2B+G+9 MUHAISNAH RESI BLDG**

**NAS 2 RESIDENTIAL BUILDING - B+G+6+ROOF**





**G+6 RESIDENTIAL**



**G+6 RESIDENTIAL**



**DISTRICT ONE - PHASE 3A.1  
G+14 RESIDENTIAL**



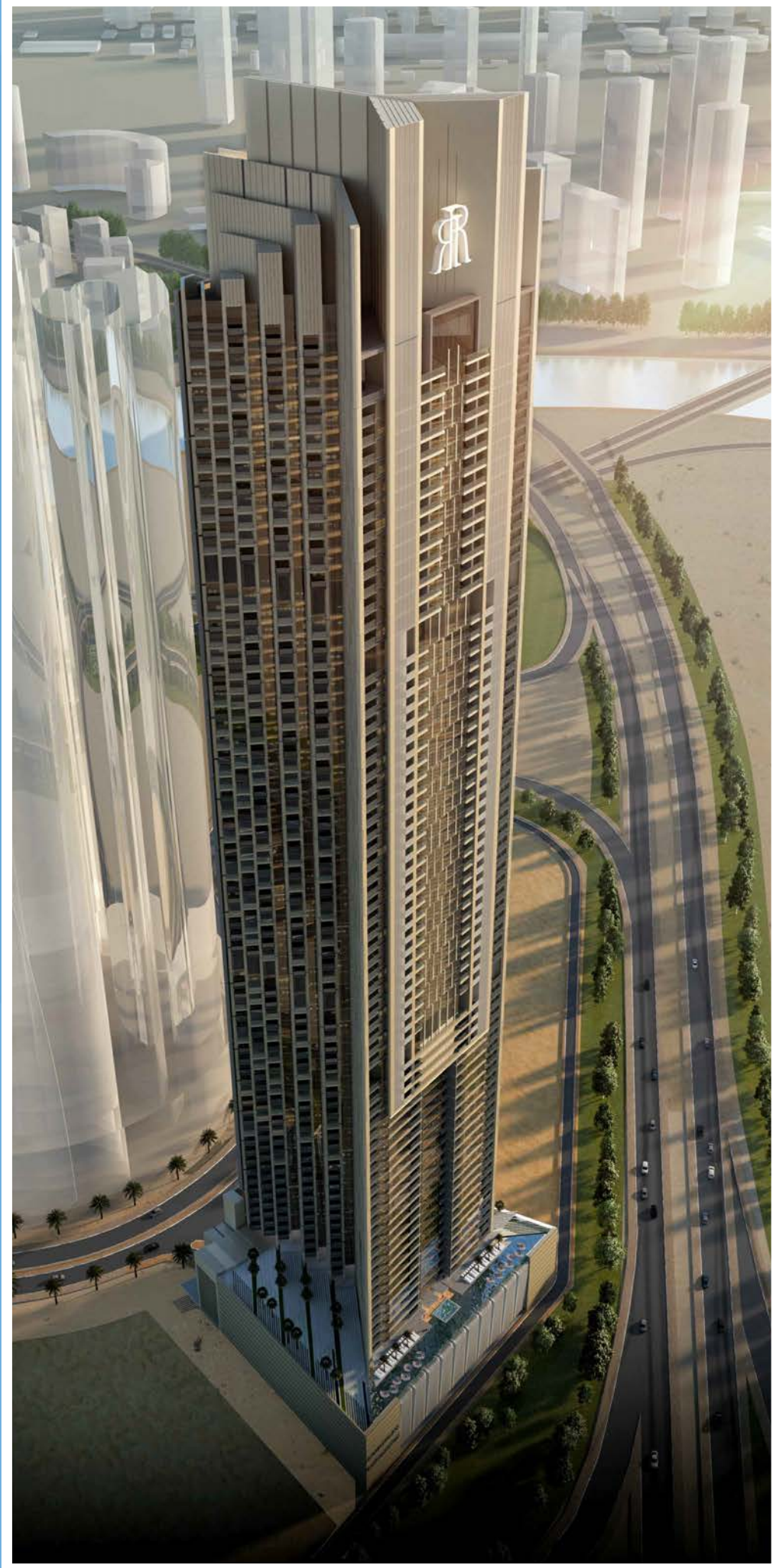

**B+G+MEZZ+5P+69F COMMERCIAL RESI. TOWER - BUSINESS BAY DUBAI**

**NAKHLAT JUMEIRAH DUBAI  
B+G+2 RESIDENTIAL VILLA**



**DISTRICT ONE - PHASE 3A.1  
G+20 RESIDENTIAL**





**INTERCONTINENTAL RESIDENCE SUITES 3B+G+MZ+2P+19F+R**

4B+G+M+39+44+MECH @ JLT, DUBAI.



SPINNEYS HEADQUARTER OFFICE & RETAIL @ NAD AL SHEBA 1 DUBAI



**G+2B+12+GYM EMRATI HOTEL BLDG JADDAF**

**COMM. RESI. @ RIGGA AL BUTEEN**

**VISA HQ - MEDIA CITY**



**B+G+1P+4+R RESI. BLDG. - JVC DUBAI**





GLOBAL ACADEMY

HARTLAND INTERNATIONAL SCHOOL



LABOUR CAMP





**NAS RESIDENTIAL**

AL FURJAN VILLAS



# Product Index

## A

Adjustable Waler Coupler - 65  
Alu. Adjustable Beam - 39  
Alu Erection Rod - 38  
Alu Top Deck Bearing - 36  
Articulated Waler Coupler - 65  
Assembly Fork - 13

## B

Beam Coupler Plate - 66  
Beam Fixing Device - 61  
Bearing, Outer Corner - 60  
BKS Align Strut - 69  
Bk Strut Connector - 68  
Bottom Ladder - 91  
Bracing Clamp - 12, 30, 38

## C

Chamfer Strip - 89  
Circular Column - 87, 88, 89  
Column Waler - 63  
Concreting Platform - 90  
Connecting Angle - 28  
Connecting Pin U 20x190 - 66  
Corner Connector 60x60 - 60  
Corner Connector L24 - 60  
Corner Waler Coupler - 65  
Crane Hook - 28

## D

Drop Head - 36

## E

Engineering Design - 110  
EWST Mesh - 30  
EWST Railing Post - 37

## F

Flange Clamp - 64  
Flange nut 3 wing 100 V - 98  
Formwork Site Photos - 116

## G

Galvanized Plate 12x12 - 63  
Galv. Fork Head 8/20 - 12  
Galv. Table Head - 28  
Galv. Tripod - 12, 28, 39

## H

H20 Base Shoe SQ - 13, 29  
H20 C-Hook - 30  
H20 Extension Piece - 62, 68  
H20 Timber Beam - 11, 27, 56, 58, 59, 64  
Head Support Shoe - 37  
Hexagonal Coupler Galv. - 98  
Hinged Connector - 60  
Hinge Striker - 90  
Horizontal strut - 93

## J

Joining Wedge - 61

## L

Ladder Safety Cage - 92  
Ladder stirrup - 92  
Lifting Bracket - 67  
Lifting Hook - 93  
Locking Pin - 90  
Locking Pin Stop - 90  
Loop Tie - 98

## M

Material Test Certificate - 100  
Moveable Handrail - 90

## O

Outer Corner Bearing - 60  
Outside Corner U - 66

## P

Plate Washer Nut - 68  
Platform Handrail Short - 92  
Prop Retainer - 37  
Push Pull Strut - 67  
Push Pull Strut Base - 67  
Push Pull Strut Head - 67  
Pushpull Strut UVR - 97

## R

Railing Post - 29, 61  
Railing Shoe - 36  
Removable Ladder - 92  
Rigid Coupler - 45, 99  
Rod Adjustable - 93

## S

Safety Multiple Clamp - 38  
Safety Post - 13, 29, 37  
Scaffold Tube - 45, 99  
Service console - 93  
Shifting Trolley - 31  
Slab Table System - 24  
Sprag Brace - 62  
Spring cotter 5mm - 66  
SS Support Frame (HD System) - 94  
Steel Column Panel - 87  
Steel Prop - 10, 11, 26, 27, 34, 35  
Steel Waler - 64, 98  
Steel Waler Connector - 60  
Strut Wedge Strap - 62  
Supporting Frame UVR - 97  
Swivel Coupler - 45, 99

## T

T15 Adjustment Frame 33 - 44  
T15 Base Jack - 43  
T15 Diagonal 33 - 44  
T15 Diagonal Brace - 44  
T15 End Frame 10 - 43  
T15 Frame 100 - 43  
T15 Frame 133 - 44  
T15 Head Jack - 43  
Table Clamp - 28  
Table Head 30 - 31  
T-Bolt - 12, 30, 38

T-Bolt-L - 38  
TB Walkway Bracket - 61  
Tension Nut - 63  
Tension Strap - 60  
Tie Nut 230 - 63, 91  
Tie Rod - 66, 99  
Timber Beam Attachment-C - 13, 29  
Toe Board Retainer - 29, 37  
Top Deck Edge Support - 36  
Topdeck Panel - 35  
Top Ladder - 91  
Transverse Beam - 39  
T - Waler Coupler - 65

## V

Vito Tie Nut - 63, 91

## W

Waler Coupler - 65  
Waler Head Anchor U - 66  
Waler Holder Hook U - 98  
Wall Strut - 62  
Wedge - 61  
Wing Nut - 63  
Working Bracket - 68, 99



# ewst

**Scaffolding • Formwork • Engineering**

## Dubai

Emirates World Scaffolding Trading LLC.  
Sales & Rent of Formwork & Scaffolding Systems  
National Industries Park  
Jebel Ali – Dubai – UAE  
P.O. Box No: 38277  
Tel : +971 (4) 8867196  
Fax : +971 (4) 8867197  
Email : [Info@ewstuae.com](mailto:Info@ewstuae.com)  
Web : [www.ewstuae.com](http://www.ewstuae.com)